

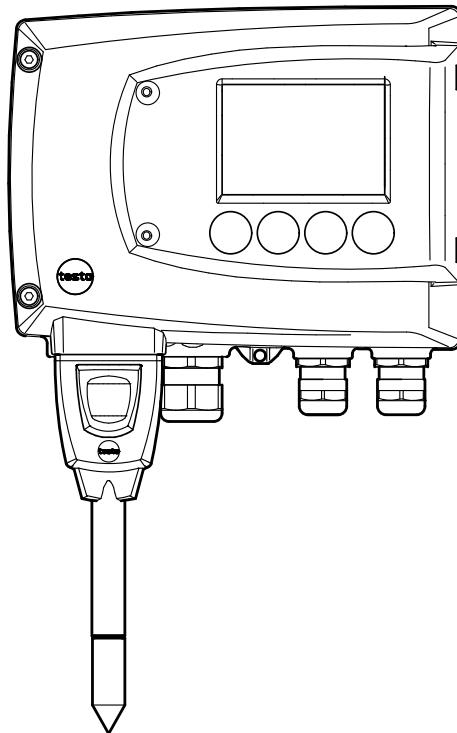

**testo 6681 Profibus · Humidity transmitter  
with Profibus module  
testo 6610 · Probes  
P2A software · Parameterizing, adjusting and analyzing  
software**

**Instruction manual Volume 1**

**en**





# Safety and the environment

## Avoiding electrical hazards

Never use the instrument and connected probes to measure on or near live parts!

Damaged mains cables must only be replaced by authorized personnel.

Only have the transmitter wired and connected by authorized personnel with the voltage disconnected.

You must always comply with the regulations applicable in your country to the opening and repair of electrical equipment.

## Avoiding personal injury/damage to equipment

Installation, setting and calibration work must only be carried out by qualified and authorized personnel!

Only open the instrument when this is expressly described in the instruction manual for installation, maintenance or repair purposes.

Observe the permissible storage, transport and operating temperatures.

Never store or operate the product with solvents and do not use any desiccants.

Do not use the instrument for control purposes at the same time as operating or servicing the transmitter.

Only operate the product properly, for its intended purpose and within the parameters specified in the technical data. Do not use force.

Carry out only the maintenance and repair work that is described in the documentation. Follow the prescribed steps when doing so. Use only OEM spare parts from Testo.

Any additional work must only be carried out by authorized personnel.

Otherwise Testo will not accept any responsibility for the proper functioning of the instrument after repair and for the validity of certifications.

## Protecting the environment

Send the product back to Testo at the end of its useful life. We will ensure that it is disposed of in an environmentally friendly manner.

# About this document

Please read this documentation through carefully and familiarize yourself with the product before putting it to use. Keep this document to hand so that you can refer to it when necessary. Hand this documentation on to any subsequent users of the product.

The following conventions are followed in this document:

**Character/  
display:**

**Explanation/example**



With the signal word **Warning!**:

Warns against hazards which could result in serious physical injury if the precautionary measures indicated are not taken, e.g.:

De-energize the mains connection before connecting the transmitter!



With the signal word **Caution!**:

Warns against hazards which could result in minor physical injury or damage to equipment if the precautionary measures indicated are not taken, e.g.:

Observe the permissible operating temperature!



Important information, e.g.:

Administrator rights are required to install the program under Windows® 7, 8 and 10.



Aim of action, e.g.:

➤ **Assembling the instrument at the process connection:**



Requirement that must be met, e.g.:

✓ USB drivers are installed.

Character/ display:	Explanation/example
1	<p>Steps are numbered if a certain sequence of actions must be followed, e.g.:</p> <ol style="list-style-type: none"> <li>1 Loosen and remove housing screws.</li> <li>2 Remove the upper part of housing.</li> </ol>
▪	<p>A step is not numbered if there are no further steps or if the step is optional, e.g.:</p> <p style="padding-left: 40px;">Insert probe connector into socket of testo 6681 until it engages.</p>
" to "	<p>Example entries are in inverted commas, e.g.:</p> <p>The value "0" results in ....</p>
<b>Bold type</b>	<p>Elements of the program interface or instrument display, e.g.:</p> <p>The instrument designation appears in the <b>instrument/parameter file list</b>.</p> <p>Select <b>Main Menu Channel 1</b> and confirm with SET.</p>
...>...	<p>Functions/paths within a menu, e.g.:</p> <p><b>Start &gt; All Programmes &gt; Testo &gt; P2A Software.</b></p>
[ ]	<p>Buttons which start an action, e.g.:</p> <p>Confirm the software key with <b>[OK]</b>.</p>
CAPITAL LETTERS	<p>Keys on the instrument or keypad, e.g.:</p> <p>Press ESC.</p>

# Contents

<b>1</b>	<b>TRANSMITTER.....</b>	<b>9</b>
1.1	Specifications.....	9
1.1.1	Functions and use .....	9
1.1.2	Scope of delivery .....	9
1.1.3	Accessories.....	10
1.1.4	Technical Data.....	10
1.1.5	Dimensions .....	12
1.2	Product description .....	13
1.2.1	At a glance .....	13
1.2.2	Usable probes.....	14
1.2.3	Display and keypad .....	15
1.2.4	Service interface .....	15
1.2.5	Relay board (option) .....	15
1.2.6	Analog outputs.....	16
1.2.7	Parameters .....	16
1.2.8	Scaling .....	17
1.2.9	Alarm handling.....	19
1.3	Commissioning .....	20
1.3.1	Insert Profibus module (Order no. 0554 6686).....	20
1.3.2	Assembling the instrument .....	22
1.3.3	Connecting the instrument.....	25
1.3.4	Connect instrument to the bus system .....	42
1.3.5	Configure Profibus module using EDD .....	49
1.3.6	Adjusting the instrument .....	55
1.4	Operation .....	65
1.4.1	Relationship between user menu and mini-DIN socket is active.....	65
1.4.2	Key cover .....	66
1.4.3	Password protection .....	67
1.4.4	Structure of user menu .....	68
1.4.5	Overview of the testo 6681 user menu .....	69
1.4.6	The individual main menus .....	71

1.5	Status, warning and error messages.....	83
1.5.1	Status messages .....	83
1.5.2	Warning messages .....	84
1.5.3	Transmitter error messages.....	86
1.5.4	Status codes in cyclical service .....	87
1.5.5	Handling alarm messages .....	87
1.5.6	Namur fault conditions .....	89
1.6	Maintenance and cleaning.....	90
1.6.1	Maintaining the instrument.....	90
1.6.2	Cleaning the instrument.....	90



## Certificate

PROFIBUS Nutzerorganisation e.V. grants to

**Testo AG**

**Testostr. 1; 79853 Lenzkirch; Germany**

the Certificate No.: **Z01237** for the PROFIBUS Slave:

**Product Name:** Testo 6680  
**Revision:** 1.0; SW/FW: V1.0; HW: V1.0  
**GSD:** Tes\_0A8A.gsd; File Version: 1.0; 10.10.2006

This certificate confirms that the product has successfully passed the certification tests with the following scope:

<input checked="" type="checkbox"/>	DP-V0	MS0, Set_Slave_Add
<input checked="" type="checkbox"/>	DP-V1	MS2, I&M
<input type="checkbox"/>	DP-V2	
<input checked="" type="checkbox"/>	Profile	PA Devices V 3.01
<input checked="" type="checkbox"/>	Physical Layer	RS485

Test Report Number: itm 641 PA 01/01  
 Authorized Test Laboratory: itm, München, Germany  
 Expiry date of Certificate: December 19, 2009

The tests were executed in accordance with the following documents:  
 "Test Specifications for PROFIBUS DP Slaves, Version 3.0 from November 2005" and  
 "Test Specification for PA Devices, Profile 3.1, Version 4.9.0, November 2005"  
 This certificate is granted according to the document "Framework for testing and certification of PROFIBUS products".

Karlsruhe, February 07, 2007



*[Signature]*  
 (Official in Charge)

Board of PROFIBUS Nutzerorganisation e. V.

*[Signature]*  
 (E. Küster)

*[Signature]*  
 (K.-P. Lindner)



# 1 Transmitter

## 1.1 Specifications

### 1.1.1 Functions and use

The testo 6681 humidity transmitter with Profibus module is used in conjunction with plug-in, adjusted probes from the testo 6610 range.



Please refer to *volume 2, chapter 2* for information about commissioning, operating and maintaining the testo 6610 probe.

The testo 6681 humidity transmitter is suitable for the following applications with Profibus networking, for example:

- Process instrumentation
- Clean rooms
- Test benches
- Drying processes
- Production and storage air quality
- Complex room climate applications.

### 1.1.2 Scope of delivery

The scope of delivery of the testo 6681 humidity transmitter includes the following:

- Key cover
- Rear panel bracket

### 1.1.3 Accessories

The following accessories are available for the testo 6681 humidity transmitter:

- Protection caps for probes
- Mains unit
- P2A software (parameterizing, adjusting and analyzing software)
- Assembly accessories.



Information about accessories and their order numbers can be found in *volume 2, chapter 4.2* or on the website at [www.testo.com](http://www.testo.com).

### 1.1.4 Technical Data

#### Parameters

Humidity (various variables and units)  
 Temperature (°C/°F)

#### Measuring range

Depends on probe

#### Accuracy

Depends on probe

#### Resolution

0.1 % RH or 0.1 °C/0.1 °F

#### Meas. cycle

1/s

#### Interface

Mini-DIN for P2A software  
 (parameterizing and adjusting software)

Optional Profibus-DP module

#### Voltage supply

4-wire (separate signal and supply lines):  
 20 - 30 V AC/DC,  
 300 mA power consumption

#### Maximum load

- 4-wire: 500 Ω (power output)

#### Analogue output\*

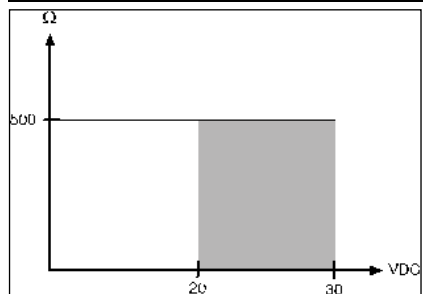

- 0 to 1 V ± 1.5 mV (4-wire) or
- 0 to 5 V ± 7.5 mV (4-wire) or
- 0 to 10 V ± 15 mV (4-wire) or
- 0 to 20 mA ± 0.03 mA (4-wire) or
- 4 to 20 mA ± 0.03 mA (4-wire)

#### Resolution of analog output

12 bit

#### Relay

4 relays, 250 V AC/DC, 3 A (optional)

#### Display

2-line LCD with plain text line  
 (optional)

---

**Housing operating temperature**

---

-40 to +70 °C/-40 to +158 °F, with display  
from 0 to 50 °C/+32 to +122 °F

With integrated relay: -40 - +60 °C

---

**Storage temperature**

---

- 40 to 80 °C/-40 to +176 °F

---

**Housing, weight**

---

Metal: 1.960 kg

Profibus: 0.610 kg

---

**Protection class**

---

IP 65 only if the transmitter is wired  
and/or seal plugs are inserted

---

**Directives, standards and tests**

---

EC Directive: 2014/30/EU

## 1.1.5 Dimensions

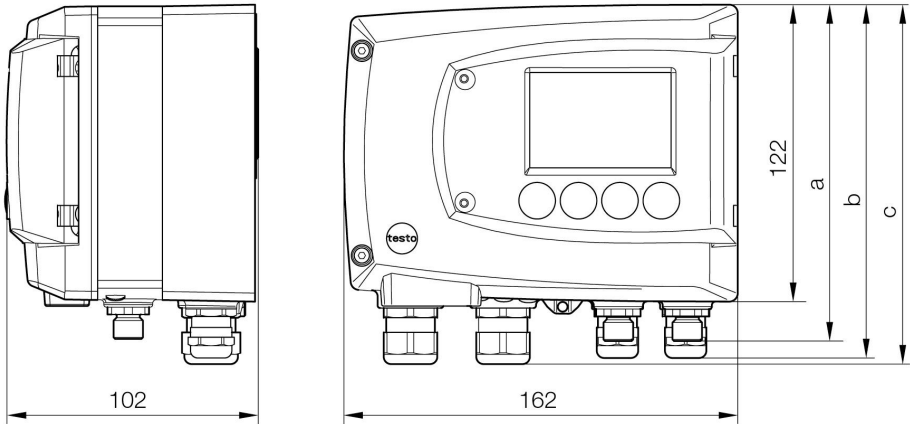

<b>Dimensions in mm</b>	<b>a</b>	<b>b</b>
With M 20 cable couplings	144	147
With NPT cable couplings	144	144
With M plug-in connections	143	

# 1.2 Product description

## 1.2.1 At a glance

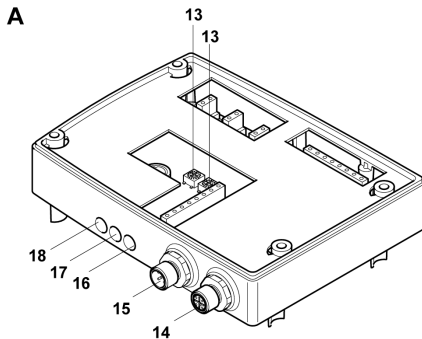
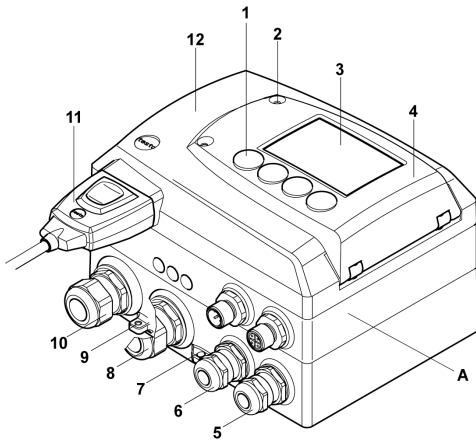

- 1 Keys (with optional display)
- 2 Service flap screw connection (self-locking, 2x)
- 3 Display (optional)
- 4 Service flap
- 5 M 16 x 1.5 screw connection\*, e.g. analog outputs
- 6 M 16 x 1.5 screw connection\*, e.g. voltage supply
- 7 Eyelet for measuring point panel
- 8 M 20 x 1.5 screw connection\*, e.g. relay R 3 and R 4
- 9 Earthing/PE connection
- 10 M 20 x 1.5 screw connection\*, e.g. relay R 1 and R 2
- 11 Probe connector (testo 6610)
- 12 Upper part of housing

\* Alternatively, NPT cable couplings or M plug-in connections are available

- A Profibus module
- 13 Rotary encoder switch for addressing
  - 14 Profibus M12 socket
  - 15 Profibus M12 connector
  - 16 LED: Bus error
  - 17 LED: System error
  - 18 LED: Supply

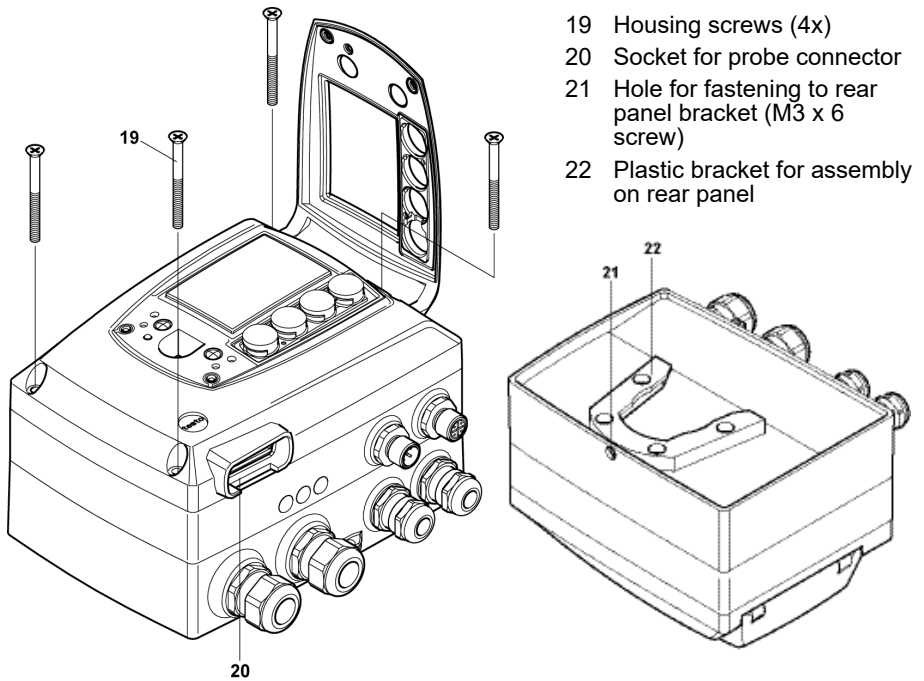

## 1.2.2 Usable probes

The testo 6681 humidity transmitter can be used with the following probes:

Probe	Article no.	Characteristic
testo 6611	0555 6610-L11	<b>Wall</b> probe version; accuracy to $\pm 1\%$ RH; temperature range -20 °C to +70 °C/-4 to +158 °F
testo 6612	0555 6610-L12	<b>Duct</b> probe version; accuracy to $\pm 1\%$ RH; temperature range -30 °C to 150 °C/-22 to +302 °F
testo 6613	0555 6610-L13	<b>Cable</b> probe version; accuracy to $\pm 1\%$ RH; temperature range -70 °C to +180 °C/-94 to +356 °F
testo 6614	0555 6610-L14	<b>Heated cable</b> probe version; accuracy to $\pm 1.0\%$ RH; temperature range -40 °C to +180 °C/-40 to +356 °F
testo 6615	0555 6610-L15	<b>Trace humidity cable</b> probe version; dew point to -60°Ctd; temperature range -40 °C to +120 °C/-40 to +248 °F
testo 6617	0555 6610-L17	<b>Cable with cover electrode monitoring</b> probe version; accuracy to $\pm 1.2\%$ RH; temperature range -40 °C to +180 °C/-40 to +356 °F

## 1.2.3 Display and keypad

The display option allows the testo 6681 humidity transmitter to be operated via the display and four keys.

The LCD display consists of two 7-segment lines for displaying readings and units and of an information line (for status messages, for example).

The brightness and contrast of the display and the background lighting (permanent or off) can be changed via the user menu or the P2A software.

## 1.2.4 Service interface

Behind the service flap is the parameterizing socket (mini-DIN) as an interface to the P2A software.

## 1.2.5 Relay board (option)

This has a floating switch capacity of 250 V AC/3 A. The switching limits and hysteresis can be set via the display or the P2A software or via the Profibus. Further features include:

- Function of changeover contacts (NC/NO contacts) freely selectable
- 12 terminals for a total of 4 relays.



If no relays are available, settings for monitoring limit values or alarms can still be controlled via the display. The alarm status will be shown on the display.



Only have the transmitter wired and connected by authorized personnel with the voltage disconnected.

## 1.2.6 Analog outputs

For analog outputs, the testo 6681 has either

- 2 or optionally 3 current outputs of 4 to 20 mA/0 to 20 mA (4-wire) or
- 2 or optionally 3 voltage outputs of 0 to 1 V/0 to 5 V/0 to 10 V (4-wire).

The transmitter can be ordered with a third analog output as an option.



If the Profibus module is integrated directly into the testo 6681 humidity transmitter (order code B77), it has two current outputs 4 ...20 mA.

## 1.2.7 Parameters

The following parameters are displayed:

- Relative humidity in %RH (technical)
- Relative humidity in % WMO\* (calculation according to the WMO standard)
- Temperature °C and °F
- Dewpoint in °Ctd and °Ftd
- Absolute humidity in g/m<sup>3</sup> and gr/ft<sup>3</sup>
- Degree of humidity in g/kg and gr/lb
- Enthalpy in kJ/kg and BTU/lb
- Psychrometer temperature in °Ctw and °Ftw
- Water vapour partial pressure in hPa and "H<sub>2</sub>O (inch H<sub>2</sub>O)
- Water content in ppm<sub>vol</sub> and % vol
- Dewpoint of H<sub>2</sub>O<sub>2</sub> mixture in °Ctm and °Ftm
- Mixture humidity H<sub>2</sub>O<sub>2</sub> in %RH<sub>m</sub>



\*It is possible that condensation appears as of a displayed humidity starting from 70 % and is shown on the display. This unit is used in meteorology, for example. According to the WMO, the Magnus coefficient is used for sub-cooled water in the calculation of relative humidity.



Calculated humidity variables correspond to the medium of air. With other gases/gas compositions, deviations may occur, e.g. with the enthalpy

## 1.2.8 Scaling

There are three types of min./max. values:

### 1 The measuring range

The maximum sensor performance is in this range. Values outside of the measuring range are displayed via messages, for example. Refer to table (see below) for the measuring range.

### 2 Standard scaling

The output signals are assigned to this measuring range as standard:

- during delivery if no entries are made in the order code
- after exchanging the unit, the measuring range recorded in the instrument is applied as standard.



The transmitter even retains its scaling with the voltage disconnected.

Refer to table (see below) for the measuring range.

### 3 The maximum settings for the manual scaling

- the values are not expressly given in the table. The maximum limits can be calculated as follows:

$X = \text{difference between MIN. and MAX. value of the standard scaling}$   
(Max. value of standard) + (50 % of X)  
(Min. value of standard) - (50 % of X)

- It is thus possible to scale beyond the measuring range, e.g. for the adjustment of the scaling limits to standard values of a PLC. However, the physical measurement range limits are the deciding factor when defining alarms.

Parameter	Unit	Probe	Measuring range Physical at 1013 hPa		Standard scaling MUF measuring range	
			MIN	MAX	MIN	MAX
Temperature	°C	6611	-20	+70	-20	+70
	°F	6611	-4	+158	-4	+158
	°C	6612	-30	+150	-30	+150
	°F	6612	-22	+302	-22	+302
	°C	6613	-70	+180	-40	+180
	°F	6613	-94	+356	-40	+356
	°C	6614, 6617	-40	+180	-40	+180
	°F	6614, 6617	-40	+356	-40	+356
	°C	6615	-40	+120	-40	+120
°F	6615	-40	+248	-40	+248	
relative humidity	% RH		0	+100	0	+100
WMO relative humidity	% RH		0	+100	0	+100
Mixture humidity H <sub>2</sub> O <sub>2</sub>	% RH <sub>m</sub>		0	100	0	100
Dewpoint	°Ctd	6611	-20	+70	-80	+100
	°Ftd	6611	-4	+158	-112	+212
	°Ctd	6612, 6613, 6614, 6617	-20	+100	-80	+100
	°Ftd	6612, 6613, 6614, 6617	-112	+212	-112	+212
	°Ctd	6615	-60	+30	-80	+100
	°Ftd	6615	-148	+212	-112	+212
Mixture dewpoint (H <sub>2</sub> O <sub>2</sub> )	°Ctm		-20	+100	-20	+100
	°Ftm		-4	+212	-4	+212
Absolute humidity	g/m <sup>3</sup>	all probes	0	600	0	2000
	gr/ft <sup>3</sup>		0	250	0	800
Degree of humidity	g/kg	all probes	0	13300	0	9500
	gr/lb		0	93000	0	66500
Enthalpy	kJ/kg		-40	99999	-40	8000
	BTU/lb		-18	43000	-18	3500

Parameter	Unit	Probe	Measuring range Physical at 1013 hPa		Standard scaling MUF measuring range	
			MIN	MAX	MIN	MAX
			Psychrometer temperature	°Ctw		-40
	°Ftw		-58	210	-40	356
Water content	ppm vol H2O		0	99999	0	99999
	% vol		0	100	0	100
Water vapour partial pressure	hPa		0	1000	0	7000
	inchH2O		0	400	0	2800

## 1.2.9 Alarm handling

For upper and lower alarm limits, individual alarms as well as collective alarms can be specified. If the collective alarm function is activated, an alarm is triggered as soon as the alarm limit of an alarm is exceeded, if this alarm is assigned to the collective alarm.

The testo 6681 monitors limit values using relays. If a reading is outside the limit values, a relay to be specified by the user is switched.

If the reading reverts to more than a specified hysteresis below or above the limit value, the alarm is cancelled.

In addition, information about the occurrence of error/status messages can be provided by means of a collective alarm relay, see *chapter 1.5, Status, warning and error messages*.



If multiple alarm messages are activated at the same time, the last alarm is shown. If the alarm is cancelled again, the previous messages are no longer shown.



Example:

If the condensation of the probe begins, the "Condensation" message appears on the display and the "Start" status display. If the condensation is over, the status display changes from "Start" to "End".

# 1.3 Commissioning

## 1.3.1 Insert Profibus module (Order no. 0554 6686)

The Profibus module can be ordered retroactively as an accessory. It can easily be installed in the testo 6681 humidity transmitter.

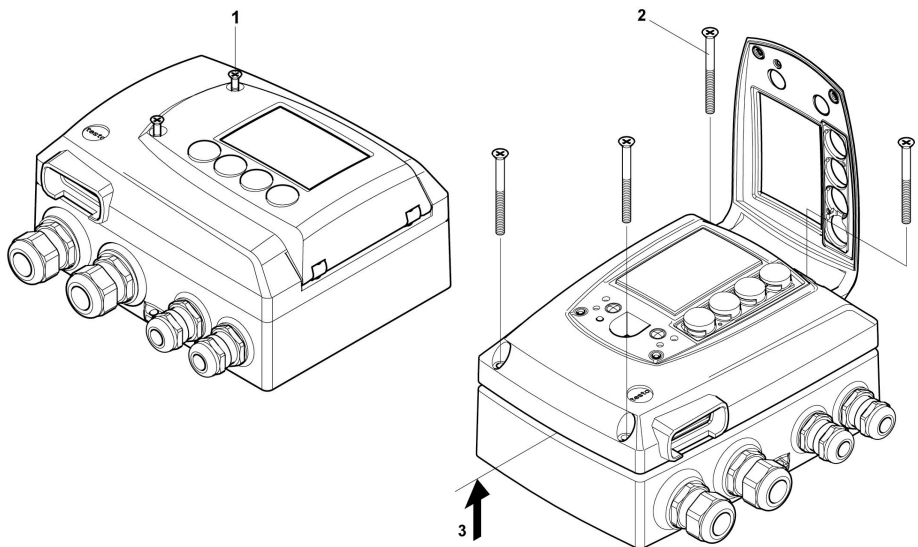

✓ The probe connector must be disconnected.

- 4 Loosen screw connection **(1)** of service flap and open the flap.
- 5 Loosen and remove housing screws **(2)**.
- 6 Remove upper part of housing **(3)** and place on a clean surface.

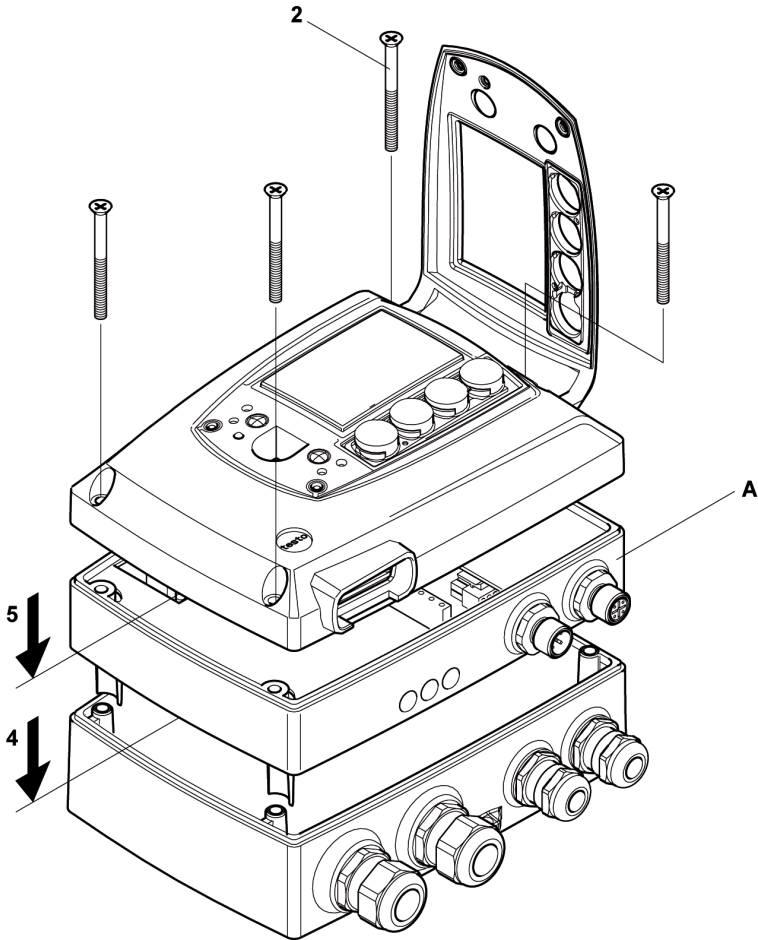

- 7 Place Profibus module **(A)** on lower part of instrument **(4)**.



If necessary, manually set the address using the rotary encoder switches (see *chapter 1.3.3.6* before fixing the instrument in place.

- 8 Set on upper part of instrument **(5)** and fix in place using housing screws **(2)**.

## 1.3.2 Assembling the instrument

### 1.3.2.1 Wall mounting (for testo 6611/6613/6614/6615/6617 probes)

➤ **Attaching rear panel bracket**

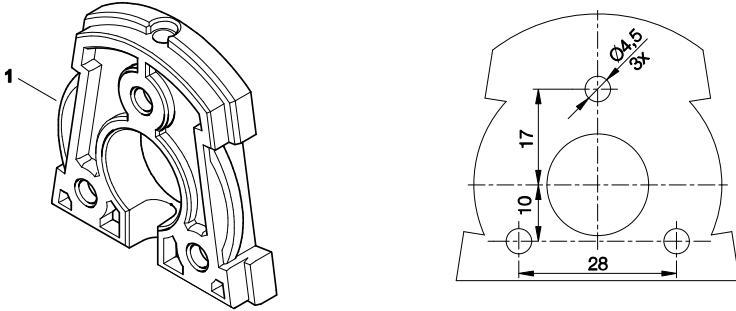

- 1 Remove locking screw (item **(4)** of drawing on page 21) and detach rear panel bracket from plastic bracket (item **(2)** of drawing on page 21).
- 2 Hold rear panel bracket in assembly position and mark the three drill holes.
- 3 Drill three holes ( $\varnothing 5$  mm) and insert dowels where necessary.
- 4 Screw on rear panel bracket.  
Remember that the clamping brackets **(1)** must face the wall.

➤ **Fastening instrument to rear panel bracket**

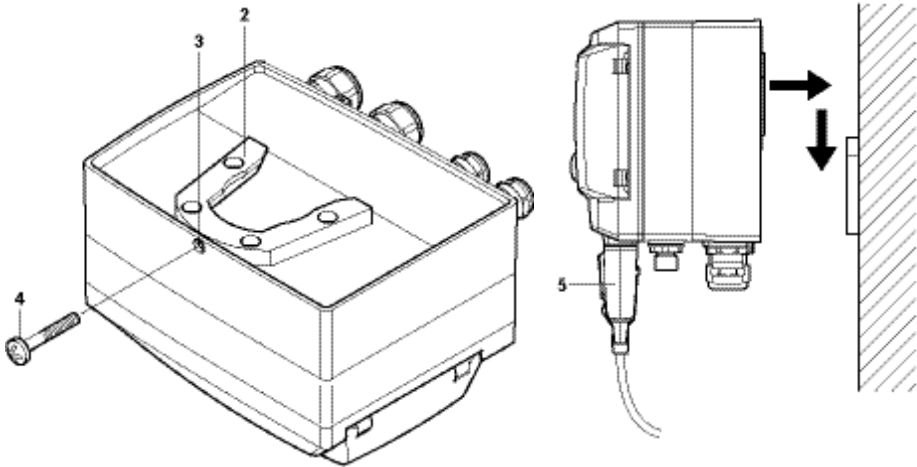

- 1 Slide plastic bracket **(2)** on the back of instrument onto rear panel bracket until it engages (see arrows).
- 2 Insert screw **(4)** through hole **(3)** and screw into rear panel bracket.
- 3 Insert probe connector **(5)** into socket until it engages.

### 1.3.2.2 Duct mounting (for testo 6612 probes)

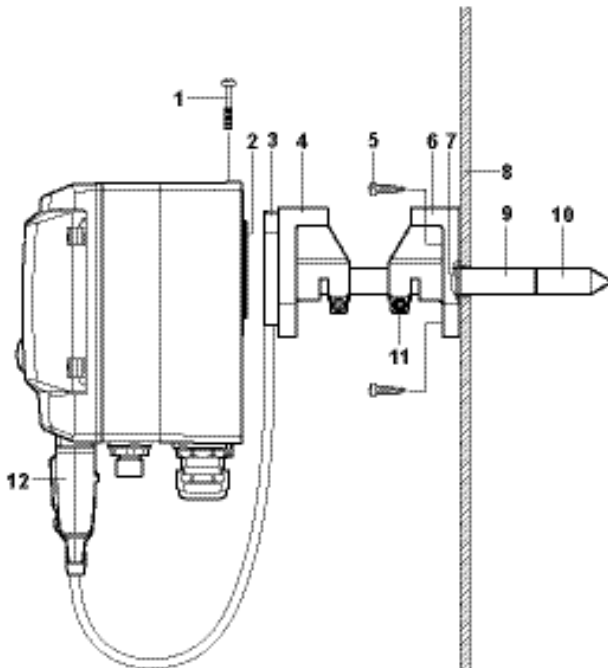

- 1 Hold wall/duct bracket (order no. 0554 6651) **(6)** against duct wall **(8)** and mark drill holes for wall/duct bracket and probe shaft.
- 2 Drill a hole ( $\varnothing$  12,5 mm) in the duct wall to feed through the probe shaft.
- 3 Fasten wall/duct bracket **(6)** to duct wall with screws **(5)**.
- 4 Push probe shaft **(9)** with filter **(10)** through the middle hole of the mounting bracket.



The wall/duct bracket **(6)** has an O-ring **(7)** to seal it against the duct. Feed the probe shaft **(9)** carefully through the wall/duct bracket so that the O-ring is not damaged.

- 5 Fix the correct position of the probe shaft **(9)** with screw **(11)** and mark (insert probe shaft as far as possible).



- 6 Slide plastic bracket (2) on the back of the transmitter onto bracket (3, 4) until it engages.



Take the weight of the transmitter into account. Ensure that the brackets (4, 6) are fastened securely.

- 7 Insert screw (1) through hole on the top of the instrument and screw into bracket (3).
- 8 Insert probe connector (12) into socket until it engages.

### 1.3.3 Connecting the instrument

#### ➤ Opening the instrument

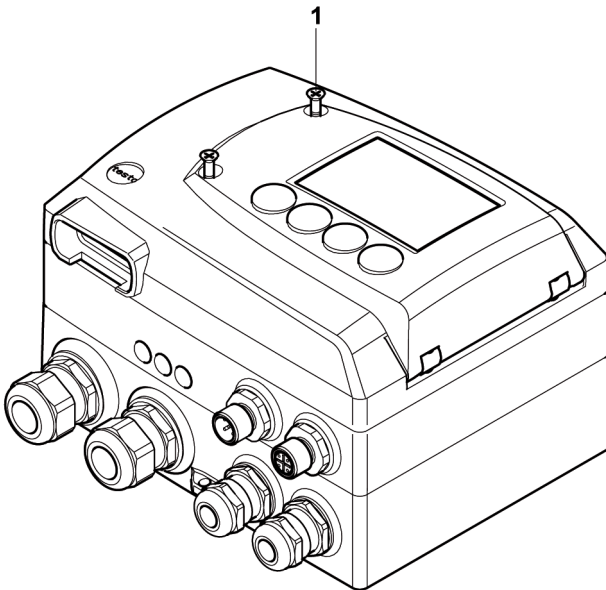

- 1 Loosen screw connection (1) of service flap and open the flap.

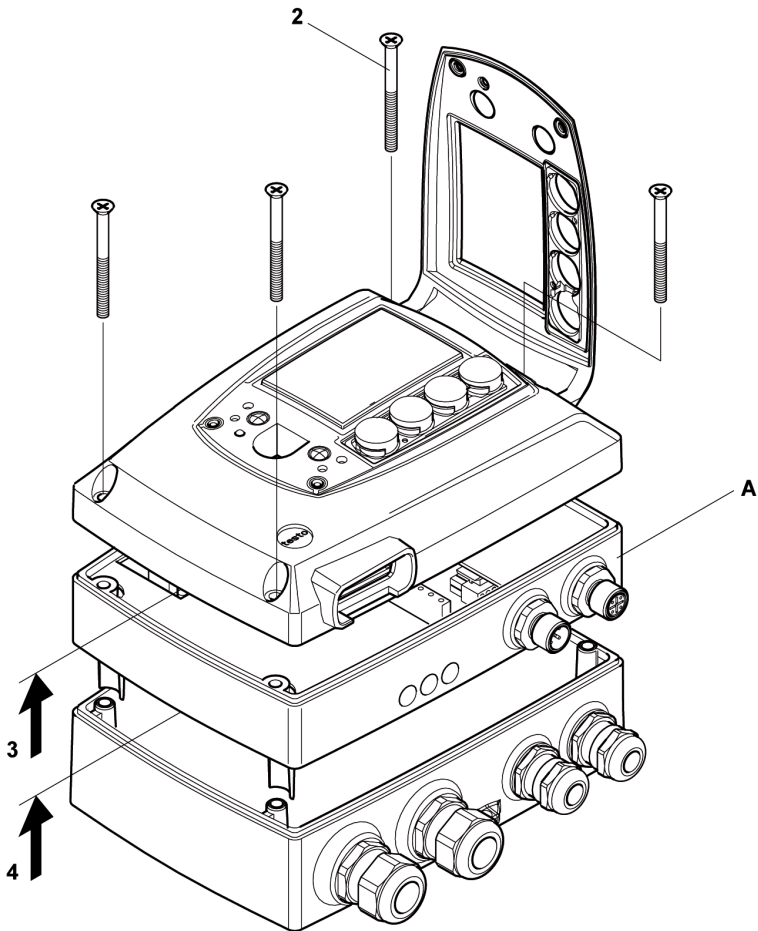

- 2 Loosen and remove housing screws (2).



Important.

The Profibus module (A) is already separated from the upper and lower parts of the instrument when the housing screws (2) are removed.

- 3 Remove upper part of housing (3) and place on a clean surface.
- 4 Remove Profibus module (A) from lower part of housing (4) and also place on a clean surface.



**Warning!**

Electrical voltage.

Danger of short-circuit!

De-energize the mains connection before connecting the transmitter!



Only have the transmitter wired and connected by authorized personnel with the voltage disconnected.

### 1.3.3.1 Overview of terminals

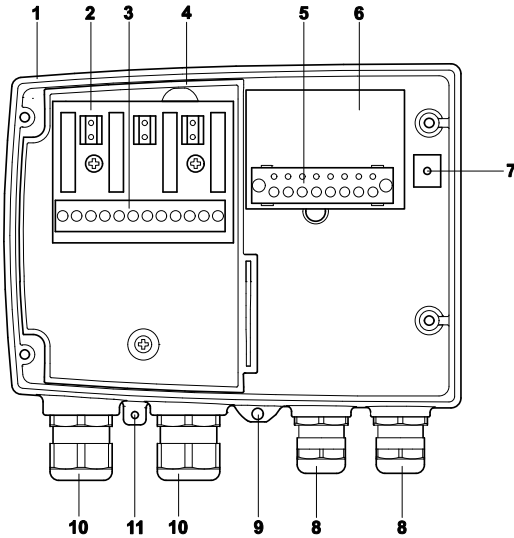

1 Lower part of housing

2 Relay board (option)

3 Relay terminals

4 Insulating trough for relay board

5 Terminal strip for voltage supply and analog outputs\*

\* The transmitter testo 6681 with integrated Profibus module (order code B 77) has two current outputs 4 to 20 mA.

6 Terminal board

7 Earthing terminal (internal)

8 M 16 x 1.5 screw connection\*\*

9 Earthing terminal (external)

10 M 20 x 1.5 screw connection\*

11 Eyelet for measuring point panel

\*\* Alternatively, NPT cable coupling or M plug-in connection.



The following description of the terminals refers to this overview and its numbering.

### 1.3.3.2 Connecting voltage supply and analog outputs

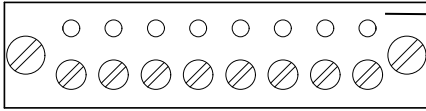

Terminal strip for voltage supply and analog outputs (item (5) of **Overview of terminals**, chapter 1.3.3.1).

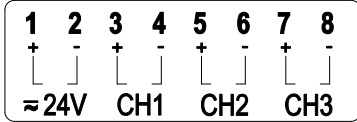

- 1 Feed cable with voltage supply and analog signal lines through opened M 16 x 1.5 screw connection (item (8) in Overview of terminals, chapter 1.3.3.1).
- 2 Strip the cable ends, clamp wire end ferrules on and screw down onto voltage terminals.
- 3 Close M 16 x 1.5 screw connection (item (8) in Overview of terminals, chapter 1.3.3.1).

#### Wiring diagram for 2-wire system (4 - 20 mA)

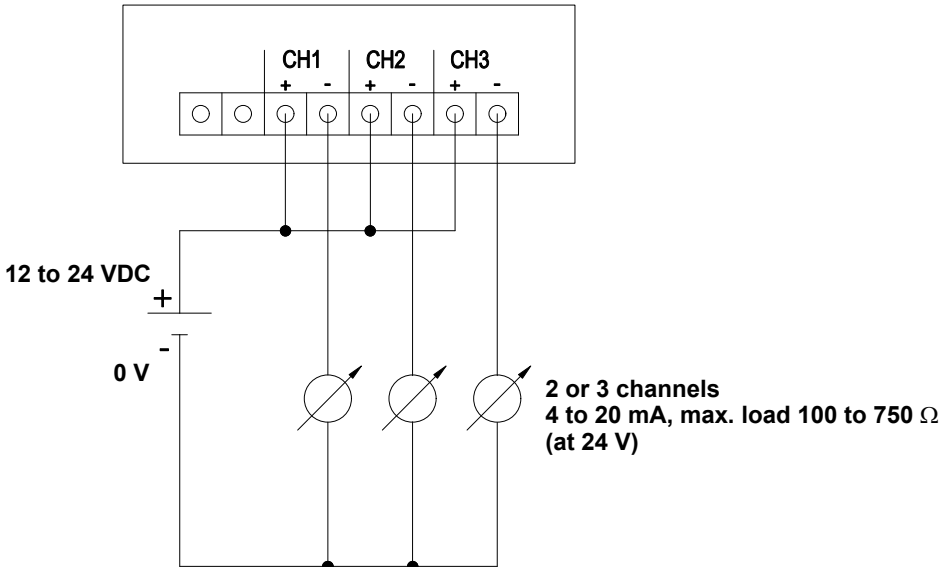



If the channels have to be galvanically isolated, a separate mains unit must be used for each channel.

### Wiring diagram for 4-wire system (0 to 20 mA/4 to 20 mA/0 to 1 V/0 to 5 V/0 to 10 V)

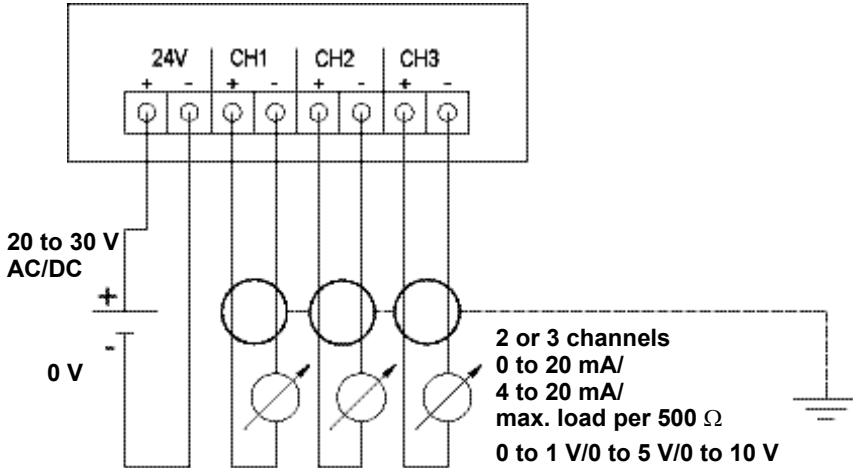

Requirement for the connecting cable of the supply:

- Insulated with cross-section of at least 0.25 sq. mm.
- The supply line must be secured against exceeding 8 A.
- An OFF switch must be installed in an easily accessible position close by and be marked as such.

- 1 Feed connection cables of the two, or optionally three, channels through opened M 16 x 1.5 screw connection (item **(8)** in *Overview of terminals, chapter 1.3.3.1*).
- 2 Strip the cable ends, clamp wire end ferrules on and screw to channel terminals as shown in diagram.
- 3 Close M 16 x 1.5 screw connection (item **(8)** in *Overview of terminals, chapter 1.3.3.1*).



Connecting the analog outputs is only required if you also wish for analog monitoring in addition to use of the readings via Profibus (e.g. for local signal use).

### 1.3.3.3 Connecting the relay outputs



Only have the transmitter wired and connected by authorized personnel with the voltage disconnected.

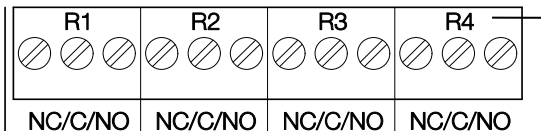

Relay terminal strip (item **(3)** of *Overview of terminals, chapter 1.3.3.1*).

There is the option of twelve terminals for a total of four relays. The designations NC/C/NO (normally closed contact/root or pin/normally open contact) are etched on the surface of the board.

#### Using PG screw connection

- 4 Feed connection cables for the relays through opened M 20 x 1.5 screw connection (item **(10)** of *Overview of terminals, chapter 1.3.3.1*).
- 5 Strip cable ends and clamp on wire end ferrules.
- 6 Connect relays according to chosen function (NC/NO) (see diagrams below; relay 1 is shown as an example of a connection).

#### Using plug-in connections (optional)



Only insert or disconnect the plug-in connection when the voltage is disconnected.

- 1 Clean the connector of the probe line and the coupling of any foreign matter.



Do not disconnect the connector of the probe line from the instrument for extended periods to protect against contamination.

## Connection note

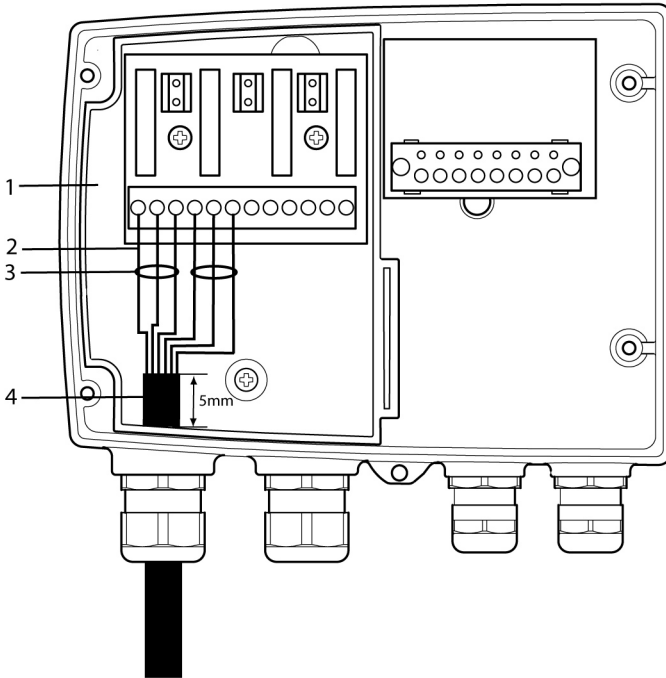

- For the connection, a double-insulated mains cable (sheathed cable) with a cross-section of at least 1.5 sq. mm must be used.
- Cable connection (2) may not be routed in a loop within the tray (1).
- It is recommended that you always tie 3 cores to one another using a cable tie (3).
- The insulation of the cable must be fed at least 5 mm (4) into the tray.



**Use of relay as NC contact (NC = normally closed)**

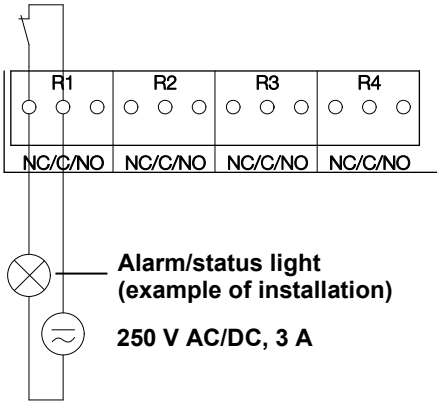

The busy light (alarm/status light) is permanently on until the relay opens or the circuit is interrupted. This circuit can therefore be used to monitor the functionality of the alarm circuit, as a cable break, for instance, is indicated by the busy light going off.

**Use of relay as NO contact (NO = normally open)**

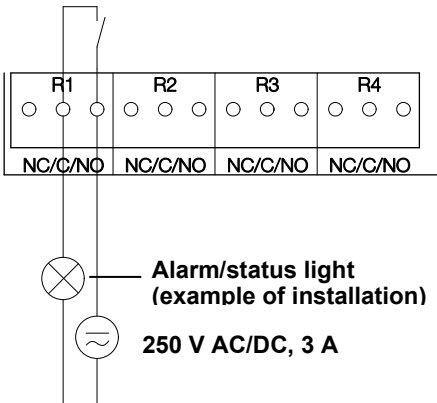



The busy light (alarm/status light) only comes on when the relay is switched (closed). Monitoring the functionality of the alarm circuit is therefore not possible with this switching operation.

- 2 Close M 20 x 1.5 screw connection (item **(10)** in *Overview of terminals, chapter 1.3.3.1.*

### 1.3.3.4 Plug-in connection option

As an option, the PG screw connections of the signal and supply lines can be replaced with plug-in connections that are installed at the housing (see Fig. 1 and 2). The relay cabling occurs via standard cable entries and PG screw connections, see Fig. 3 and 4

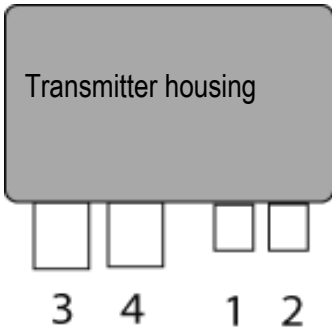

Plug-in connections for power supply and channels  
M12 plug-in connection (5-pin) socket (1)

View of the plug-in connections in the installed state from outside.



Pin	Assignment.
1	V 24 -
2	V 24 +
3	+ Ch 1
4	- Ch 1
5	PE

M12 plug-in connection (5-pin) connector (2)

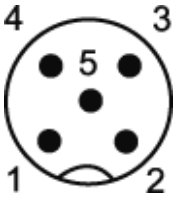

Pin	Assignment.
1	- Ch 2
2	+ Ch 2
3	+ Ch 3
4	- Ch 3
5	PE

### 1.3.3.5 Creating the PE/earthing terminal

As the testo 6681 has a metal housing, we recommend that the instrument be earthed. This can be done using the earthing terminal within the instrument (1) or the earthing terminal outside of the instrument (2).



Only use the external earthing terminal in dry interiors.

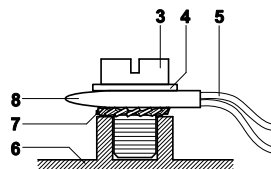
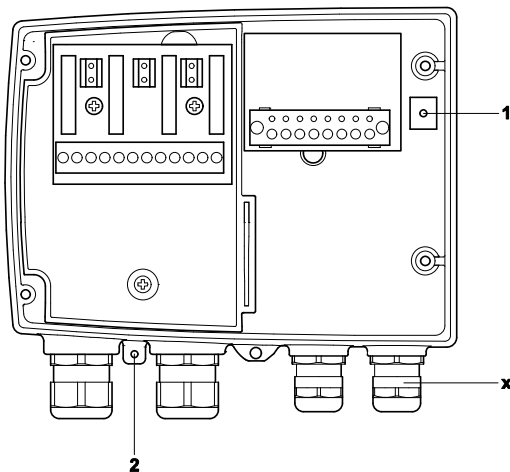

### Using the earthing terminal within the instrument

- 1 Guide PE line (yellow-green) (5) through the cable coupling (x) and fit cable lug (8). Fix this to the side of the instrument (6) using M 5 screw (3), washer (4) and snap ring (7) on the internal earthing terminal (1).
- 2 Place the other cable end on an appropriate (PE) earth conductor, e.g. an earthing bar.

### Using an earthing terminal outside of the instrument

- 1 Use shielded cable (5) with cable lug (8). Fix this in place using M 5 screw (3), washer (4) and snap ring (7) on the external earthing terminal (2).
- 2 Place the other cable end on an appropriate (PE) earth conductor, e.g. an earthing bar.

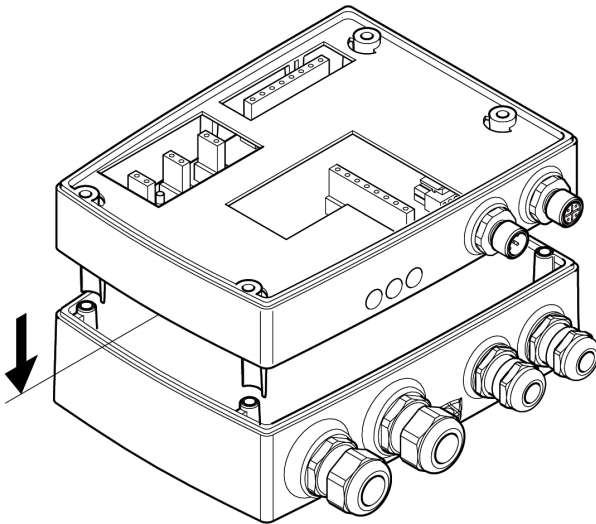

- 3 Set Profibus module on lower part of housing (see arrow).
- 4 For the configuration of the Profibus module, see following chapter.  
If you do not wish to perform a configuration, close the transmitter (see chapter 1.3.3.7)

### 1.3.3.6 Manually set address

To ensure that the individual bus subscribers can be addressed directly by the master, it is necessary that every bus subscriber is assigned a unique address.



Important:

The address of a subscriber may only be assigned once!  
Repeated assignment of an address leads to bus faults!

In the condition on delivery for the testo 6681 with Profibus module, the switch setting FF is set.

If you wish to set the address using the Profibus parameterization software, e.g. Siemens Simatic PDM (see *chapter 1.3.5.4*), the default setting is required.



The manual setting of the address (hard address) overrides the setting via the parameterization software (soft address).

- ✓ The testo 6681 must be disconnected from the bus system.

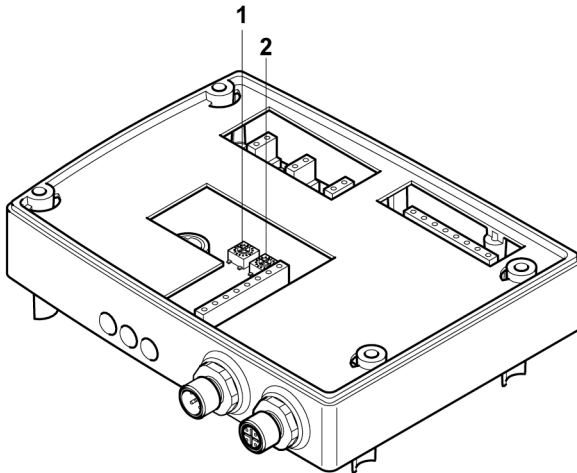

- 1 Open transmitter (see Section *Opening the instrument*, *chapter 1.3.3*).
- 2 With a Phillips screwdriver, set the address via the rotary encoder switches **(1)** and **(2)** at Profibus module (see following Section).

3 Insert Profibus module and close instrument (see *chapter 1.3.3.7*).

### Table of addresses

The addressing of the bus subscribers is performed via the rotary encoder switches (items **(1)** and **(2)**, see drawing on page 30) in a hexadecimal system (see table).

dec	(1)	(2)	dec	(1)	(2)	dec	(1)	(2)	dec	(1)	(2)
0	0	0	16	1	0	32	2	0	48	3	0
1	0	1	17	1	1	33	2	1	49	3	1
2	0	2	18	1	2	34	2	2	50	3	2
3	0	3	19	1	3	35	2	3	51	3	3
4	0	4	20	1	4	36	2	4	52	3	4
5	0	5	21	1	5	37	2	5	53	3	5
6	0	6	22	1	6	38	2	6	54	3	6
7	0	7	23	1	7	39	2	7	55	3	7
8	0	8	24	1	8	40	2	8	56	3	8
9	0	9	25	1	9	41	2	9	57	3	9
10	0	A	26	1	A	42	2	A	58	3	A
11	0	B	27	1	B	43	2	B	59	3	B
12	0	C	28	1	C	44	2	C	60	3	C
13	0	D	29	1	D	45	2	D	61	3	D
14	0	E	30	1	E	46	2	E	62	3	E
15	0	F	31	1	F	47	2	F	63	3	F

dec	(1)	(2)	dec	(1)	(2)	dec	(1)	(2)	dec	(1)	(2)
64	4	0	80	5	0	96	6	0	112	7	0
65	4	1	81	5	1	97	6	1	113	7	1
66	4	2	82	5	2	98	6	2	114	7	2
67	4	3	83	5	3	99	6	3	115	7	3
68	4	4	84	5	4	100	6	4	116	7	4
69	4	5	85	5	5	101	6	5	117	7	5
70	4	6	86	5	6	102	6	6	118	7	6
71	4	7	87	5	7	103	6	7	119	7	7
72	4	8	88	5	8	104	6	8	120	7	8
73	4	9	89	5	9	105	6	9	121	7	9
74	4	A	90	5	A	106	6	A	122	7	A
75	4	B	91	5	B	107	6	B	123	7	B
76	4	C	95	5	C	108	6	C	124	7	C
77	4	D	93	5	D	109	6	D	125	7	D
78	4	E	94	5	E	110	6	E	126	7	E
79	4	F	95	5	F	111	6	F			

### 1.3.3.7 Closing the instrument

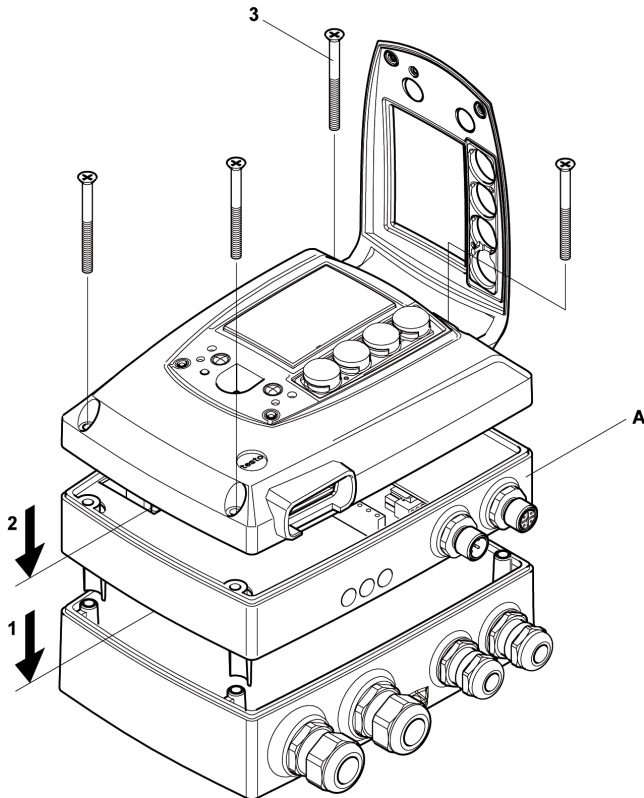

- 1 Place Profibus module **(A)** on lower part of instrument **(1)**.
- 2 Set on upper part of instrument **(2)** and fix in place using housing screws **(3)**.



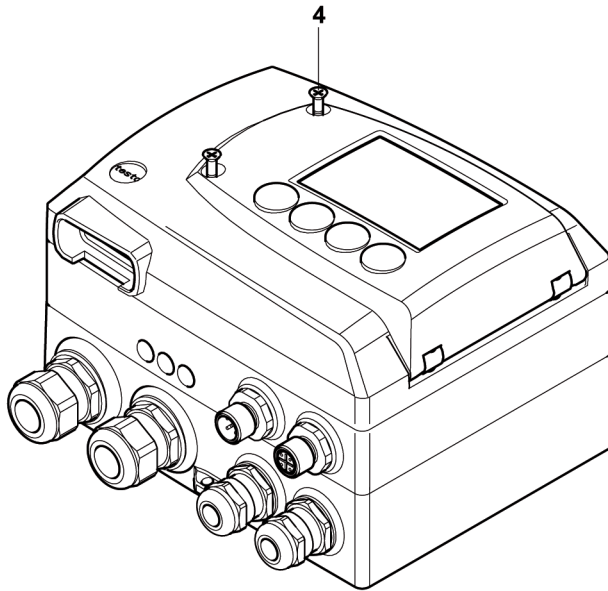

**3** Close the service flap and tighten screws **(4)**.

## 1.3.4 Connect instrument to the bus system

### Overview

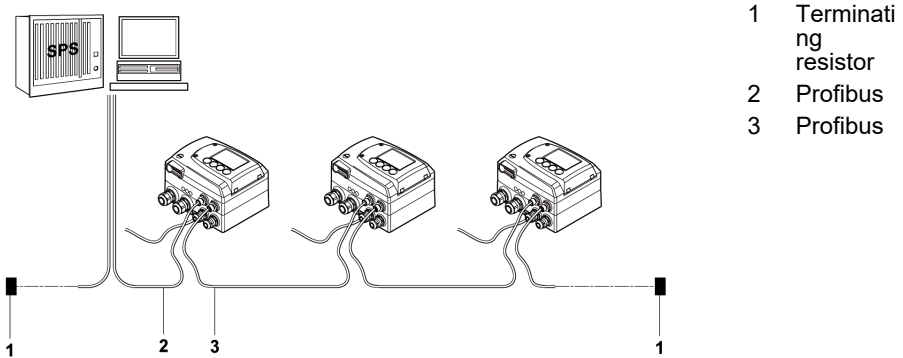

### Characteristics

- RS485 transmission technology
- Baud rates between 9 kBit/s and 12 Mbit/s
- Connected in linear structure (see Fig. above).

### Stubs

These should be avoided, as they cause reflections on the bus and thereby disruptions in communication (especially as of transfer rates  $\geq 1.5$  Mbits/s).

Connecting a bus monitor or similar is also an example of a stub, so these instruments should only be connected via active stubs (see Section *Terminating resistor, chapter 1.3.4.2*).

## Number of subscribers

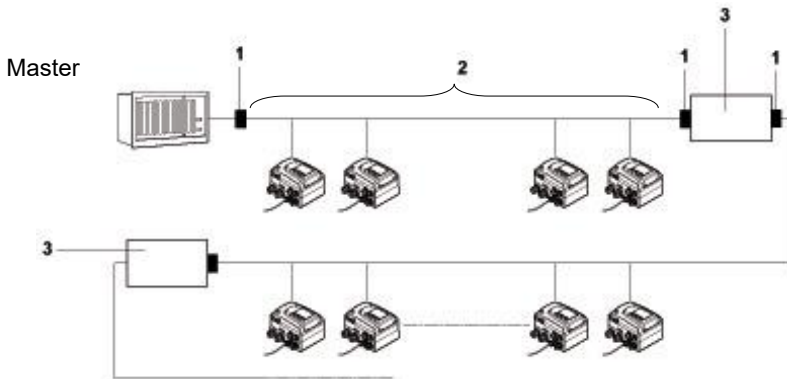

A maximum of 32 subscribers may be attached per segment **(2)**.

If more than 32 subscribers are to be integrated into the Profibus or the network dimensions are to be expanded, so-called repeaters **(3)** are to be installed which connect the individual bus segments with one another. However, a maximum of 9 repeaters **(3)** should be inserted in the transmission path between the Profibus master and the bus subscriber.

In total, a maximum of 126 subscribers (including repeaters) can be connected to the bus. The repeaters do not require their own bus address, but are included in the number of bus subscribers.

Note the bus terminating resistors **(1)** (see Section *Terminating resistor*, chapter 1.3.4.2)

### 1.3.4.1 Data transfer and baud rate

With the RS485 transmission technology, the use of shielded and twisted two-wire line of cable type A is recommended in accordance with EN 50170:

- Loop resistance < 110 Ω/km
- Surge impedance 135 to 165 Ω (at f= 3 to 20 MHz)
- Wire diameter > 0.64 mm
- Wire cross-section > 0.34 sq. mm
- Effective capacitance < 30 pF/m.



Depending on the transfer rate and number of repeaters, distances up to 10 km can be achieved using this transmission technology.

#### Line lengths

The line length depends on the baud rate (see table).

<b>Baud rate in kBit/s</b>	9.6	19.2	93.75	187.5	500	1500	12000
<b>Line length in m (cable type A)</b>	1200	1200	1200	1000	400	200	100

#### Bus cycle time

The bus cycle time is dependent on the number of bus subscribers and the selected transfer rate (see Fig.).

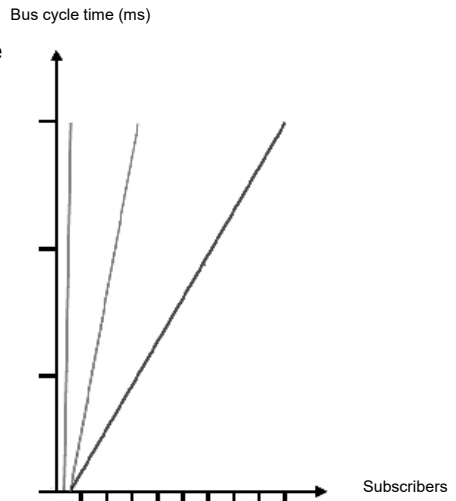

### 1.3.4.2 Electrical connection

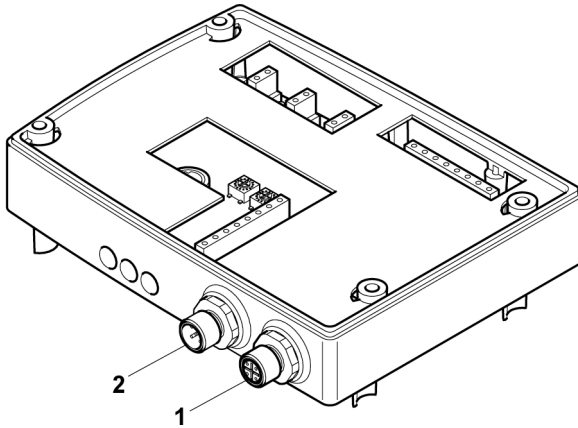

To simplify the connection of the transmitter to the Profibus, the Profibus module of the testo 6681 has pre-fabricated plug-and-socket connections.

Using the connector **(2)** and the socket **(1)** (accessory 0554 6683), the testo 6681 can be connected to the existing cable infrastructure in the linear structure of the Profibus.

The pin-assignment of the connector and the socket as per IEC 60947-5-2 is as follows:



Stecker M12

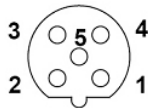

Buchse M12

- Pin 1 Supply voltage VP (5 V)
- Pin 2 RxD/TxD-N A line
- Pin 3 Reference potential to VP (DGND)
- Pin 4 RxD/TxD-N B line
- Pin 5 Shield or protective earth



When using both plug-in connections, the communication of the bus is necessarily interrupted during the integration of the removal of a field instrument.

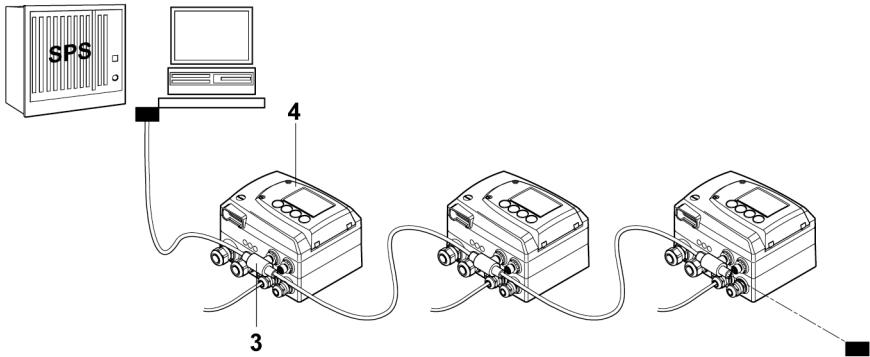

Alternatively, the transmitter can be connected to the bus system via a T plug-in connection (3) (accessory 0554 6687).

Using the T plug-in connection (3) the field instruments (4) can be disconnected during Measuring Mode and the bus communication is not interrupted. However, the T plug-in connections (3) are only advantageous up to a transfer speed of 1.5 MBits/s.

### Terminating resistor

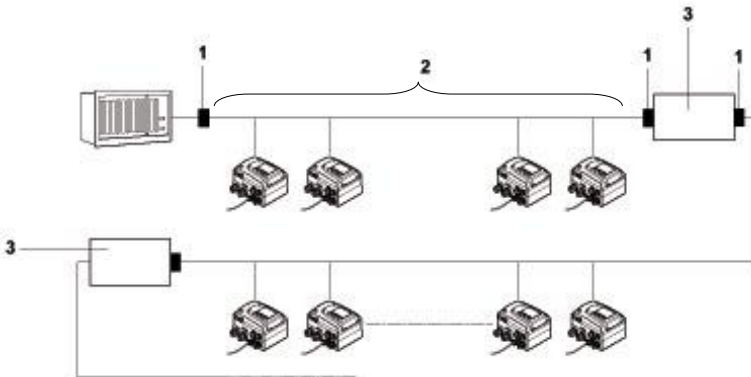

To prevent disruptions in communication due to reflections, a bus terminator (1) must be attached to the beginning and end of every bus (2) (accessory 0554 6688).

## Shielding

To safeguard the Profibus from electromagnetic influences, you should

use shielded cable type A data cables (see *chapter 1.3.4.1*).

route the bus cables as far away from all live cables as possible.

connect the double-sided cable shield to each connective bus subscriber.

ensure optimum equipotential bonding between the individual bus subscribers (e.g. by means of equipotential bonding line/common earthing bar).



Without equipotential bonding the differences in potential may lead to low-frequency equalizing currents and, in extreme cases, to destruction of the cables.

If no equipotential bonding can be ensured within the system, we recommend only applying the shield on one side and establishing capacitive connections for all further earthing points.

Use of the external earthing terminal only in interiors

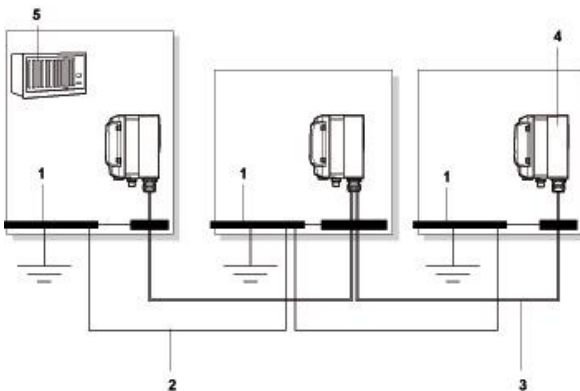

- 1 Equipotential bonding strip
- 2 Equipotential bonding line
- 3 Data cable
- 4 Transmitter (slave)
- 5 Master

### 1.3.4.3 Configuration

The communication in the Profibus occurs cyclically (permanent data exchange such as e.g. the humidity and temperature readings) as well as acyclically (data exchange dependent on event such as e.g. status, warning and error messages).

The testo 6681 has two measurement channels that are provided for the Profibus interface.

Parameters can be found in *chapter 1.2.7*.



In the condition on delivery, measurement channel 1 is set with temperature (°C) and measurement channel 2 with relative humidity (% RH) for Profibus.

To Change the factory settings for the testo 6681 via Profibus, the Profibus parameterization tool Siemens Simatic PDM is required, for example (see *chapter 1.3.5*).



For the cyclical service, you must ensure that the GSD file (General Station Description) was read into the master class 1 in the configuration tool.

The GSD can be obtained under:

[www.profibus.com/pb/applications/gsd](http://www.profibus.com/pb/applications/gsd),

[www.testo.com](http://www.testo.com) or can

be downloaded from the product CD that is included with the testo 6681.



## 1.3.5 Configure Profibus module using EDD

### 1.3.5.1 Start parameterizing software



The following description of the configuration using the Process Device Manager (PDM) refers to the stand-alone version of the Siemens Simatic PDM software.

- ✓ The project planning and parameterization tool Siemens Simatic PDM can be master class 2 (at least version 6.0 SP2).

#### 1 Start the software Simatic PDM

The program window is opened.

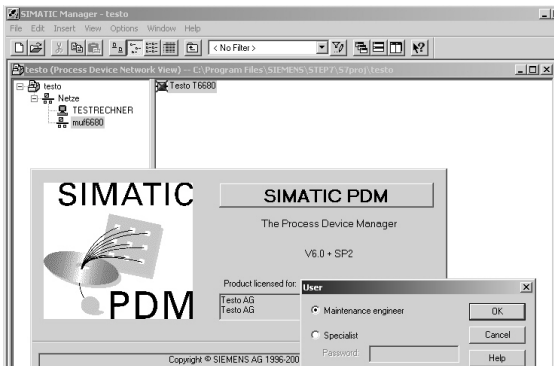

#### 2 In the right selection window, select the **testo 6680** by double clicking.

The **Simatic PDM - User** dialogue is opened.

#### 3 Select:

**Maintenance engineer** to read out the settings of the testo 6681 or

**Specialist** to parameterize the measurement channels (see *Section Menu item Output, chapter 1.3.5.3*).

#### 4 Confirm with **[OK]**.

### 1.3.5.2 Overview of user interface

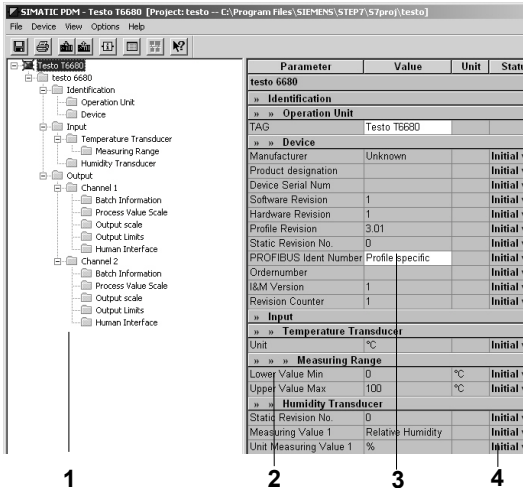

The individual menu items are shown in a tree structure in the left selection window (1).

In the right selection window (2) input fields can be opened by clicking on the white fields (3) with the right mouse button.

When settings are changed, status (4) changes from **Initial val** to **Changed**.

### 1.3.5.3 Menu items

Menu items	Explanation
Operation unit	Entry of the exact designation of the measuring point.
Device	Selection of the identification number with which the instrument registers on the Profibus. You may select:
<b>Manufacturer-specific</b>	
	Instrument registers itself with the identification number 0A8A <sub>hex</sub> . For commissioning the instrument in cyclical data communication, the manufacturer GSD is required.
<b>Profile-specific</b>	
	Instrument registers itself with the identification number 9701 <sub>hex</sub> . For commissioning the instrument in cyclical data communication, the corresponding profile GSD of the Profibus user organization (PNO) is required.



As the testo 6681 is the first humidity transmitter with a Profibus interface, no standardized humidity profile exists at this point, meaning that **Manufacturer-specific** should be selected.

**Input** Description of the Profibus input measurement channels, i.e. the parameters that the Profibus interface should be provided with. With testo 6681, these are the channels **Temperature Transducer** and **Humidity Transducer**.

**Output** Select the parameter settings for unit, filter time constants, reading scaling, limit values, etc.

### 1.3.5.4 Set address

- ✓ FF must be set at the Profibus module (see *chapter 1.3.3.7*).

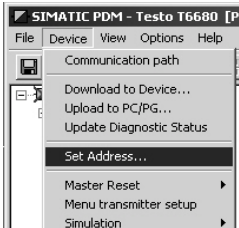

- 1 Click on **[Set address]**.

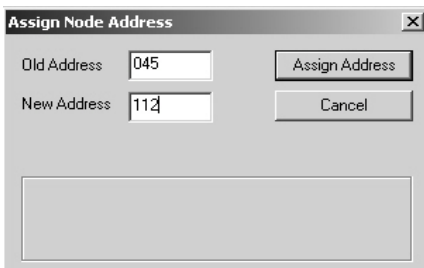

- 2 Enter addresses and confirm with **[Assign Address]**.  
The address is assigned and saved directly.



Important:

The address of a subscriber may only be assigned once. Repeated assignment leads to bus faults.

### 1.3.5.5 Parameter settings

In the Output menu item you can perform the parameter settings. To simplify the multitude of entry steps, an entry assistant is available for this.

#### Start assistant

Select **Device > Menu Transmitter setup** in the menu bar.

The dialogue is opened.

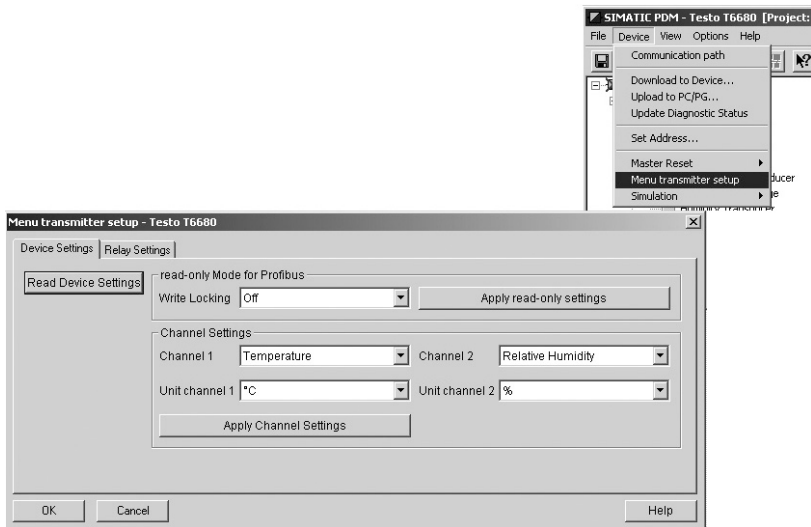

#### Instrument settings tab



Changing parameterizations is only possible when the write protection of the variables is removed.

If the write protection is activated, the settings can only be shown.

1 Click on **[Read Device Settings]**.

The display of the instrument settings is updated and the parameters, units and status of the write lock are thereby adopted in the testo 6681.

2 Select **Write locking Off** and click on **[Apply read-only settings]**.

Write protection is now deactivated.

3 In the **Channel Settings** list field, set the required parameters via the **Channel 1** and **Channel 2** pull-down menus.



Using Profibus, the temperature can only be set on channel 1. The humidity values on the other hand can be set on both channels, but a humidity value selected on one measurement channel cannot be set on the other measurement channel.

The units are updated when the parameter is changed. Alternative units that correspond to the parameter can be set using the pull-down menu.

4 Confirm with **[Apply Channel Settings]**.

The values are updated, the status was changed.

### Relay parameters tab

- ✓ In the user menu of the testo 6681 or in the P2A software, the relay status **Not used** or **Profibus** is set. Otherwise the message **no access** appears from Profibus.

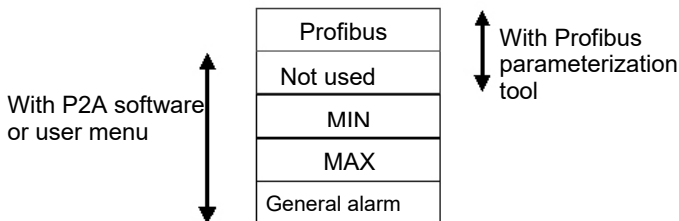

1 Click on **[Read relay parameters from transmitter]**.

The display of the relay settings is updated and the relay parameters set in the testo 6681 are applied.



For usage and parameterization of the relay, testo 6686 must be equipped with the relay options (order code H01 or H02).

Precondition for changing relay parameterizations is that you have deactivated the write protection beforehand in the **Device Settings** tab

2 Select the required relay usage in the **Apply relay parameters** list field using the **Limit Relay X** pull-down menu (see table) below.

Pull-down menu selection	Description
Relay is not being used	means that neither the transmitter nor the Profibus are using the relay.
Relay parameters managed by device	means that the relays are assigned using the testo 6681.
Limit Lo-Lo channel x	means that the relay should be used as the main alarm for monitoring the lower limit value.
Limit Lo channel x	means that the relay should be used as the pre-alarm for monitoring the lower limit value.
Limit Hi-Hi channel x	means that the relay should be used as the main alarm for monitoring the lower limit value.
Limit Hi channel x	means that the relay should be used as the pre-alarm for monitoring the upper limit value.

3 Confirm with **[Apply Relay Parameters]**.

Using **[Relay Factory Settings]** all relays are reset to **Relay is not being used**.

A precondition for this is that the write protection was deactivated beforehand and that the relays were used by the Profibus.

## 1.3.6 Adjusting the instrument

The testo adjusting concept allows the entire signal chain from the sensor signal (probe) and the digital signal (within the transmitter) through to the analog signal (transmitter output signal) to be adjusted (see diagram).

### 1-point adjustment

### 2-point adjustment

### Analog adjustment

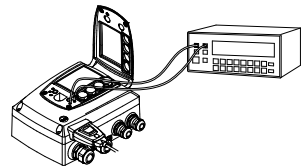
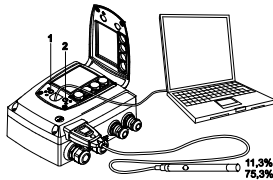

Adjustment via  
P2A software  
User menu

Adjustment 11.3 % RH and  
75.3 % RH via  
Adjustment keys (1, 2)  
P2A software  
Adjustment 20 % rH and  
80 % rH via  
User menu

Adjustment using a precise  
multimeter and transmission  
of analog reference value in  
P2A software or  
User menu

Either the 1-point adjustment or 2-point adjustment is suitable for adjusting the sensor signal - digital signal chain.

The testo 6681 transmitter has digital probes whose adjustment information is stored in the probes' internal memory. Both 1-point and 2-point adjustments can thus be carried out on another testo 6681 (e.g. in the calibration laboratory).

### 1.3.6.1 Overview: Adjustment keys and test contacts

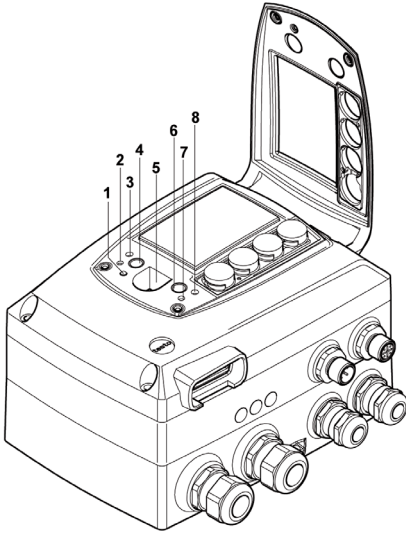

- 1 Status LED
- 2 Contact ch. 1 +
- 3 Contact ch. 1 -
- 4 Adjust key 11,3 %
- 5 Service interface
- 6 Adjust key 75,3 %
- 7 Contact ch. 2 +
- 8 Contact ch. 2 -

### 1.3.6.2 1-point adjustment (Offset)

In the 1-point adjustment, the reading at the working point is raised to the reference value so that there is no longer any deviation in the working point. The reference condition can be measured using a reference device or be created in an air conditioning cabinet.

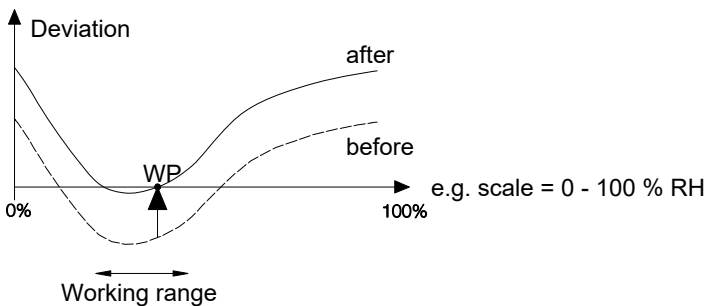

The advantage of the 1-point adjustment is the good measuring result in the working range. But the further away the measurement is from the working point, the greater the deviation can become. The 1-point adjustment should therefore only be used for a relatively narrow measuring range (working range), e.g. clean room applications, air conditioning applications for storage and similar.



The 1-point adjustment can be performed

- via the user menu (see *chapter 1.4.6.9*) or
- via the P2A software (see *volume 2, chapter 3*).



Please note that the 1-point adjustment is generally performed on the basis of the % RH and °C/°F parameters.

### 1.3.6.3 2-point adjustment

With the 2-point adjustment, the parameter is adjusted to the reference value at the two standard adjustment points 11.3 % RH and 75.3 % RH or 20 % RH and 80 % RH. The reference conditions are created either by using Testo humidity adjustment set (order no. 0554 0660, only for adjustment points 20 %RH and 80 %RH) or in the humidity generator.

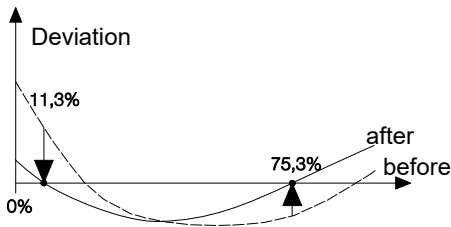

In the 2-point adjustment, the deviations between the reading and the nominal value are minimized across the entire measuring range. The 2-point adjustment is therefore recommended for large working ranges, e.g. in drying processes.

The 2-point adjustment can be performed

- via P2A software (see *volume 2, chapter 3*) or
- using the adjustment keys under the service flap, see description of how to proceed below.

The 2-point adjustment for the adjustment points 20 %RH and 80 %RH is carried out via the user menu.



A 2-point adjustment cancels any previous 1-point adjustment.



Adjustment with the standard Testo adjustment salt pots is not suitable for the testo 6614 (heated for high-humidity applications) and testo 6615 (trace humidity) probes. The reference conditions should be generated in a humidity generator to adjust these probes.

In addition, these probes can also be adjusted at a third adjustment point by Testo Service.

testo 6614: third adjustment point at 90 % RH

testo 6615: third adjustment point at -40 °Ctd/-40 °Ftd.

➤ **Adjusting testo 6681 using adjustment keys**



The 2-point adjustment for the adjustment points 20 %RH and 80 %RH is carried out via the user menu.

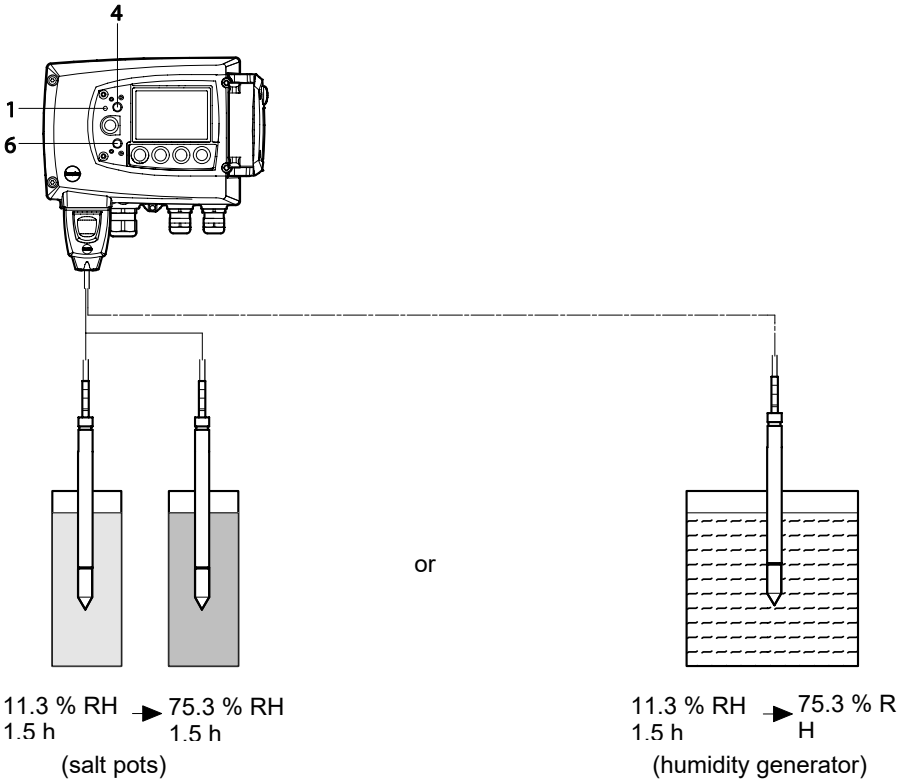

✓ The service flap of the testo 6681 is open.

- 1 Expose the humidity probe of the testo 6681 to the reference condition of 11.3 % RH for at least 1.5 hours at 25 °C.

- 2 After this equalization period, press the 11.3 % adjustment key **(4)** for at least 10 seconds with something like a ball-point pen that is not too sharp. The LED **(1)** flashes when the adjustment process begins. At the same time, the **2-point adjustment 11.3 %** status message appears on the display

Completion of the adjustment is signalled by the LED **(1)** coming on permanently and the **Probe reset** status message is shown.

- Carry out the adjustment analogously for the reference condition 75.3 % RH. Press on the 75.3 % RH adjustment key **(6)** to do this.

- 3 Close the service flap.

#### 1.3.6.4 Analog output adjustment



The analog output adjustment is only required if the analog outputs are used in addition to the Profibus output.

The purpose of adjusting the analog outputs is to adjust the signal chain from the digital signal (within the transmitter) to the analog outputs. The signal type that was appointed for the transmitter is adjusted respectively for each channel (e.g. 4 to 20 mA or 0 to 1 V, etc.)

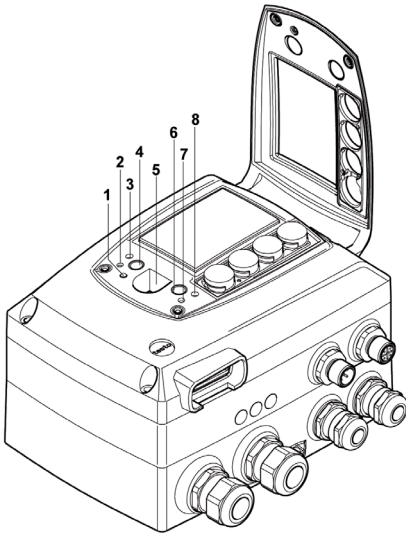

- 1 Status LED
- 2 Contact ch. 1 +
- 3 Contact ch. 1 -
- 4 Adjust key 11.3 %
- 5 Service interface
- 6 Adjust key 75.3 %
- 7 Contact ch. 2 +
- 8 Contact ch. 2 -

### ➤ Analog outputs 1 and 2 adjusted

- ✓ A precise multimeter (minimum resolution of 6.5 digits, accuracy of 100  $\mu$ A, e.g. Agilent 34401A) is available.



If only a simple multimeter is available, the analog outputs may not be adjusted.

- ✓ The service flap is open.

- 1 Connect the inputs of the multimeter with the contacts **(2)** and **(3)** for channel 1 or with contacts **(7)** and **(8)** for channel 2.
- 2 Transfer the reference analog value measured with the multimeter to the P2A software (see *volume 2, chapter 3*) or enter it via the user menu (see *chapter 1.4.6.9*).
- 3 Disconnect connections between multimeter and contacts of the testo 6681 and close service flap.

### ➤ Adjusting analog output 3 (optional)



If the optional third analog output is to be adjusted, a cable connection to measure the analog value must be installed. Do this by proceeding as follows:

- 1 Open transmitter (see *chapter 1.3.3*).
- 2 Connect measuring cable to the terminals of the third analog output and guide through the cable coupling and out of the transmitter.
- 3 Reassemble upper part of transmitter.
- 4 Connect cable ends to the inputs of the multimeter.
- 5 Transfer the reference analog value measured with the multimeter to the P2A software (see *volume 2, chapter 3*) or enter it via the user menu (see *chapter 1.4.6.9*).
- 6 Remove the upper part of the transmitter, detach the cable connections for the adjustment of the 3rd analog output and reassemble the transmitter.

### 1.3.6.5 High-humidity adjustment for testo 6614

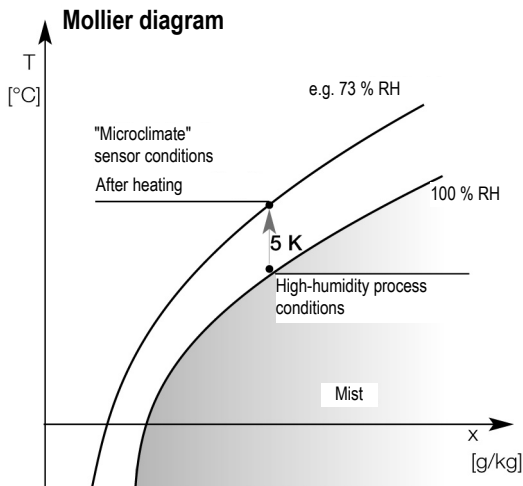

With the testo 6614, the rear of the Testo humidity sensor is heated, creating a microclimate around the sensor (within the filter) that is constantly 5 K warmer than the actual process conditions. As can be seen in the Mollier diagram, this reduces the relative humidity at the sensor from around 100 % RH to a lower value, e.g. 73 % RH. In this range, the reaction time of the sensor is noticeably shorter than in the condensation range and the risk of the sensor corroding is also reduced. Using the separate temperature probe, the testo 6681 transmitter compensates the microclimate conditions and displays the process readings.



The reference conditions (11.3 % RH and 75.3 % RH) for the 2-point adjustment of the testo 6614 should be generated in a humidity generator, as humidity adjustment sets cannot be used due to the heat generated. The adjustment can also be carried out at a third adjustment point (90 % RH) by Testo Service so that optimum accuracy is also achieved in the high humidity ranges.

### 1.3.6.6 Self adjustment of testo 6615 trace humidity probe

Conventional trace humidity probes show a steep rise in measuring uncertainty at low humidities. In the trace humidity probe of the testo 6615, these measuring uncertainties are corrected by means of an automatic self-adjustment process. This means that extremely accurate measuring results are also attained to  $-60\text{ }^{\circ}\text{Ctd}$ .

To this end, a temperature sensor is fitted on the back of the testo 6615 which is used as a heater. A humidity and temperature value pair is taken in both the unheated and heated state. The deviation of the probe obtained from these pairs of values is automatically corrected.

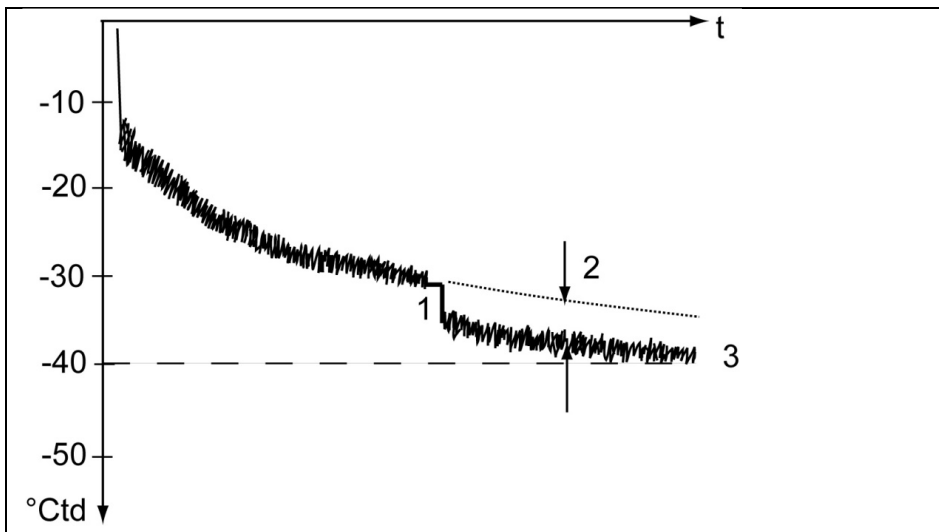

The graph shows the effect of the self-adjustment, e.g. during the Init. phase.

- 1 Self-adjustment
- 2 Correction of measurement value

### 3 Process dew point temperature

For the effectiveness of the self-adjustment the following prerequisites are decisive over the duration of the self-adjustment.

- The process temperature should not vary by more than 0.5K
- The dew point temperature should remain stable, as far as possible
- The process pressure should not vary excessively



If these prerequisites cannot be fulfilled, the values obtained during the last successful self-adjustment will be maintained.

All adjustment processes are saved in the history of the transmitter, see chapter 3.3.5 Transmitter history.

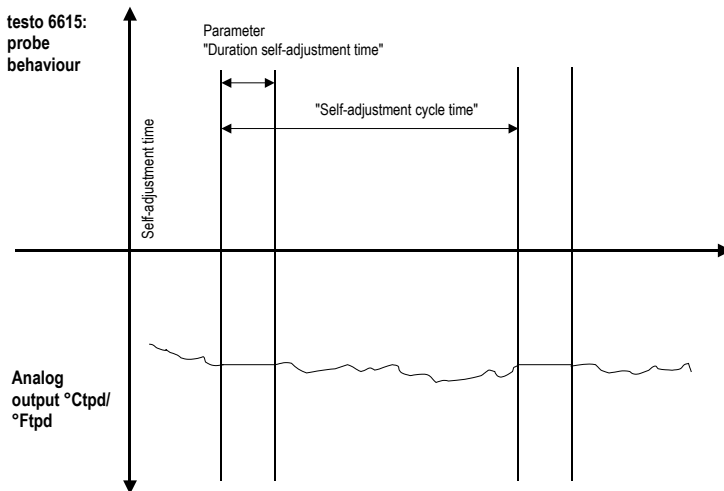

The heating time and storing of cycles can be edited in the P2A software; for example, they can be deactivated by setting the two parameters to "0".





Important:

- Deactivating the adjustment function of the testo 6615 will reduce measuring accuracy and should therefore be restricted to the shortest possible length of time.
- During the heating phase, the relay and analog outputs, the display value and output value are "frozen", see diagram above. **Self-adjustment active** is shown in the display until it has finished. The factory setting for the Self-adjustment time (incl. heating time, calculation time, cooling time) is 30 minutes per day. The cycle time can be edited via the operating menu or the P2A software.
- In the factory setting, a **third adjustment point** (-40 °Ctd) is approached for the testo 6615 in addition to the 2-point adjustment.  
This special adjustment can be performed again by your Testo Service team if necessary.

## 1.4 Operation

### 1.4.1 Relationship between user menu and mini-DIN socket is active

The testo 6681 can be parameterized using either the user menu or the P2A software (see *volume 2, chapter 2*).



The testo 6681 humidity transmitter can only be operated via the display and keypad if the display option is available.

If the testo 6681 is connected to the P2A software, the user menu is blocked for the duration of the communication. The message **Service plug** is shown in the display of the testo 6681. As soon as the P2A software is disconnected, the user menu is accessible again.

## 1.4.2 Key cover

To prevent unauthorized operation of the keys, the standard key frame can be replaced with a key cover.

If the key cover has been assembled, the service flap must be opened for operation (see Section *Opening the instrument*, chapter 1.3.3).

### ➤ Attaching the key cover

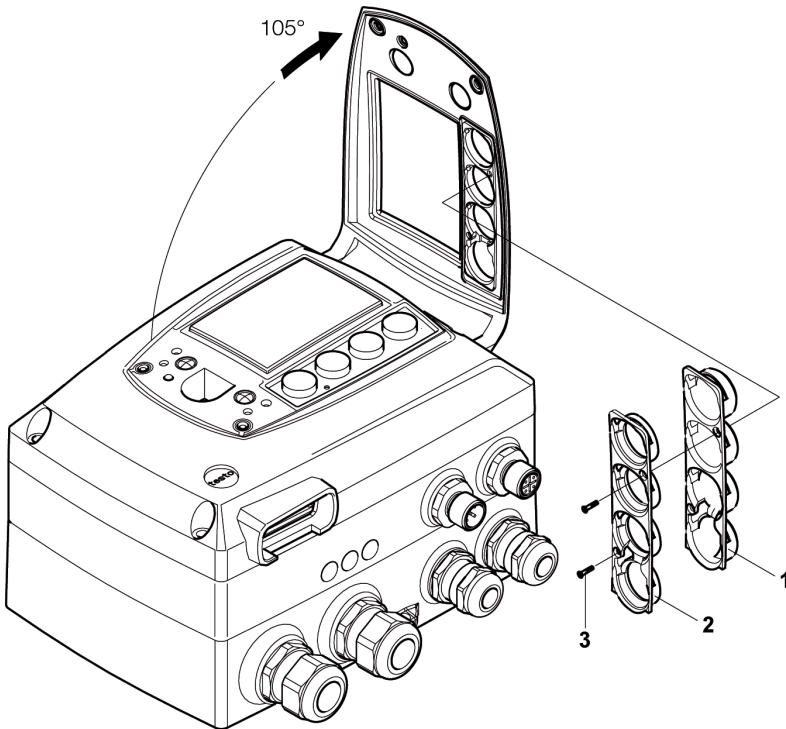

✓ The service flap is open, see *Opening the instrument*, chapter 1.3.3.

- 1 Undo screws (3) and remove key frame (2).
- 2 Insert key cover (1) into service flap and tighten screws (3).
- 3 Close and screw down the service flap.

### 1.4.3 Password protection

The user menu can be protected with a four-digit numerical code (see *Editing Main Menu Settings, chapter 1.4.6.5*) so that access to the user menu is denied to unauthorized persons not familiar with this numerical code.

If the password protection is not to be used, the numerical code "0000" must be entered. This is also the status upon delivery.

## 1.4.4 Structure of user menu

At the main menu level, the user menu comprises the following:

**Main menu of channel 1**

**Main menu of channel 2**

**Main menu of channel 3 (if this option is available)**

**Main Menu Alarm**

**Editing Settings main menu**

**Analysis main menu**

**Main Menu Messages**

**Ident main menu**

**Adjustment main menu**

**Reset main menu**

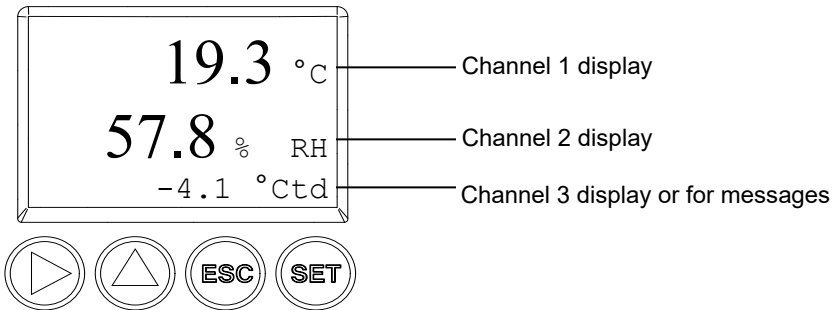

Four keys enable the user to navigate/scroll through the menus and enter/amend values and settings:

Key	Function/description
SET	In Measuring Mode: changes to parameterization In Parameterizing Mode: confirms a selection or setting
ESC	Leaves a menu (without modifying any settings)
▶	Selecting: scrolls through menus (downwards) or selectable alternatives Editing: changes to next digit (to the right)
▲	Selecting: scrolls through menus (upwards) or selectable alternatives Editing: increases the value of the current digit by 1

# 1.4.5 Overview of the testo 6681 user menu

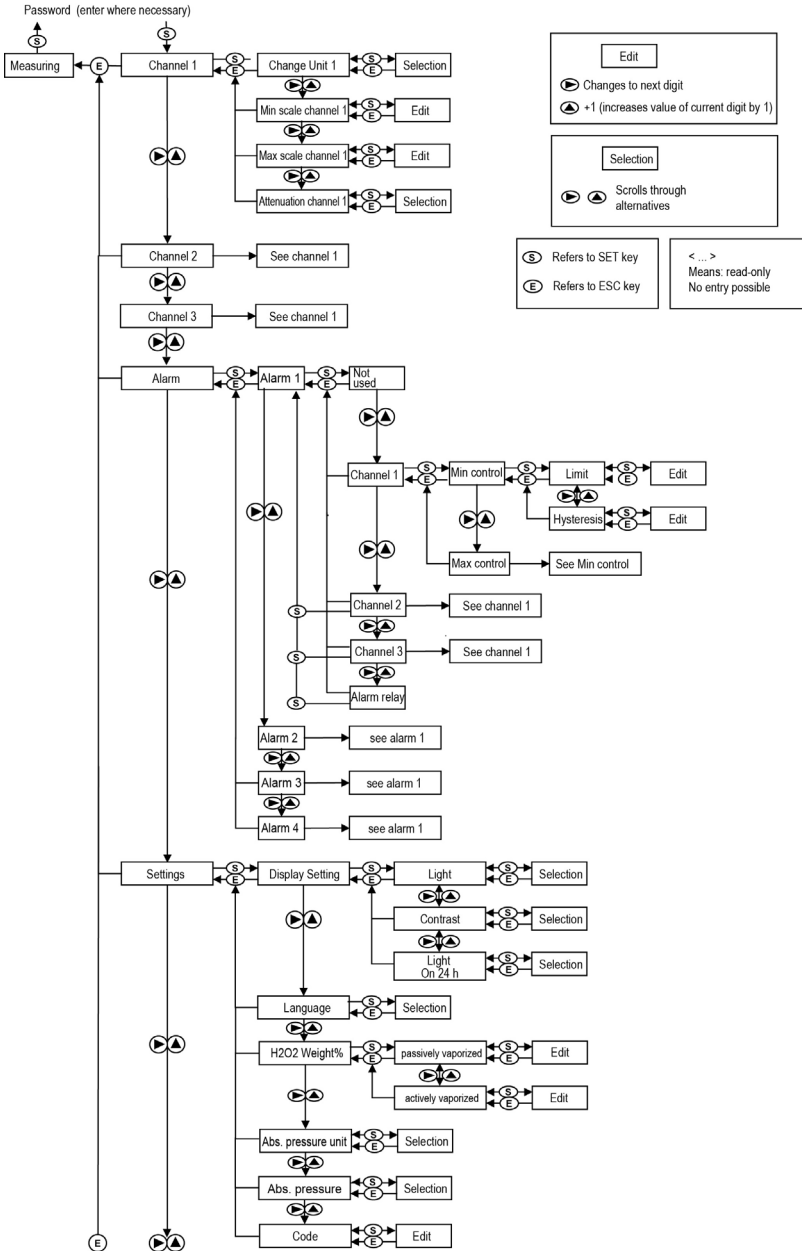

# 70 testo 6681 Profibus - 1.4 Operation

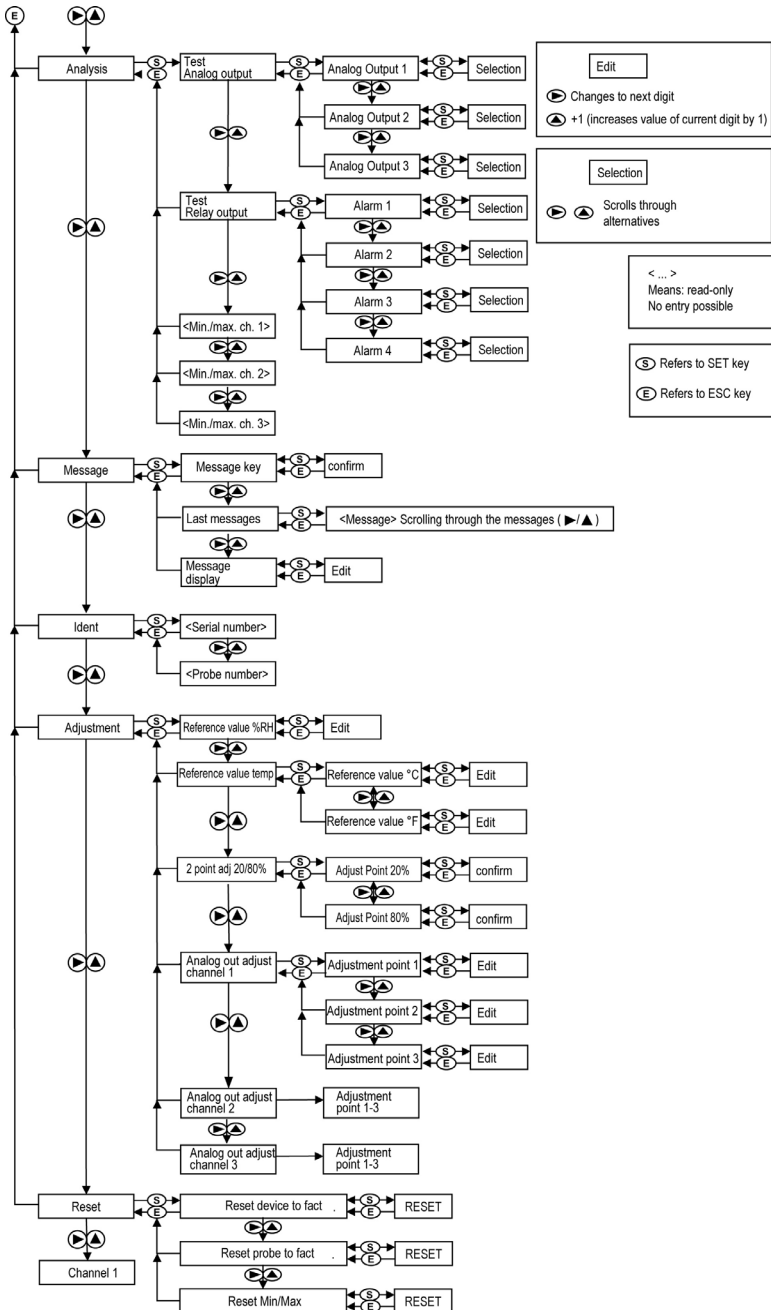

## 1.4.6 The individual main menus

### 1.4.6.1 Editing main menu of channel 1

An overview is given in *Overview of the testo 6681 user menu, chapter 1.4.5*.

You can perform basic settings for channel 1.

- 1 In Measuring Mode, press SET, select **Main Menu Channel 1** using ► or ▲ and confirm selection with SET.

One of the following parameters can now be selected using ► or ▲, after which the selection must be confirmed with SET:

#### Channel 1 unit

The parameter for this channel is selected.

Selection: % RH, °C, °F, °Ctd, °Ftd, g/m<sup>3</sup>, gr/ft<sup>3</sup>, g/kg, gr/lb, kJ/kg, BTU/lb, °Ctw, °Ftw, "H<sub>2</sub>O, hPa, ppm<sub>vol</sub>, % Vol, °Ctm, °Ftm.

Edit/select parameter with ► or ▲, confirm with SET or abort input with ESC.

#### Scale minimum for channel 1

The lower scale limit is edited;

Unit as selected above (example: 4 mA = 0 % RH).

Editing the value: Scroll one digit to the right using ►, increase value of digit by 1 using ▲. Confirm with SET or abort entry with ESC.

#### Scale maximum for channel 1

The upper scale limit is edited;

Unit as selected above (example: 20 mA = 100 % RH).

Editing the value: Scroll one digit to the right using ►, increase value of digit by 1 using ▲. Confirm with SET or abort entry with ESC.

#### Signal delay ("Damping") for channel 1

The analog signal can be delayed ("Damping"); a time constant is selected for this (1 = no delay; 15 = longest delay).

Edit/select parameter using ► or ▲, confirm with SET or cancel entry via ESC.

- 2 Continue to **Main Menu Channel 2** using ► or ▲ or return to Measuring Mode by pressing ESC.

### 1.4.6.2 Editing main menu of channel 2

See channel 1.

### 1.4.6.3 Editing main menu of channel 3 (if this option is available)

See channel 1.

### 1.4.6.4 Editing Main Menu Alarm

With the alarm, the relays, available as options, are programmed. In addition, the alarm statuses are shown on the display (top right) (even without relays). You can choose whether the alarm is to be used to monitor limit values or as a collective alarm. If an alarm is to be used to monitor limit values, you can choose between monitoring the minimum or maximum value and set a limit value and hysteresis for each alarm.



Note:

If the relays are already assigned using the Profibus, these can no longer be parameterized via the transmitter.

- 3 In Measuring Mode, press SET, select **Main Menu Alarm** using ► or ▲ and confirm selection with SET.

Four alarms can be parameterized.

- 4 Select **Alarm x** using ► or ▲ and confirm selection with SET.



➤ **Using alarm to monitor limit values**

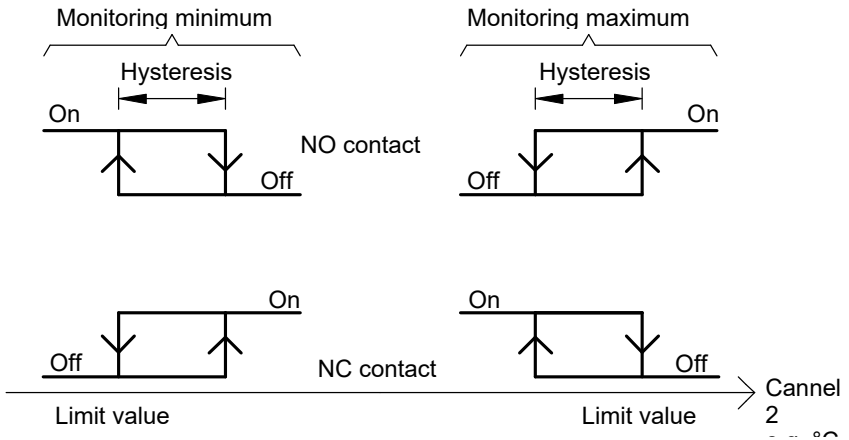

- 5 Select **Channel x** (e.g. "Channel 1") using ► or ▲ and confirm selection with SET.
- 6 Select **Max control** or **Min control** with ► or ▲ (see graphic).
- 7 Press SET and edit **limit value** and **hysteresis**: Scroll one digit to the right using ►, increase value of digit by 1 using ▲. Confirm with SET or abort entry with ESC.
- 8 Return to **Channel x** by pressing ESC.
- 9 Return to **Alarm x** by pressing ESC.
- 10 Change to the other relays using ► or ▲ and perform settings in the same way.

➤ **Using alarm as collective alarm or not using it at all**

If the collective alarm is assigned to an alarm, the relay is switched as soon as (at least) one of the warning or error messages of the testo 6681 transmitter (or the connected testo 6610 probe) is activated.



Note:

The messages affecting the collective alarm can only be selected in the P2A software, see *volume 2, chapter 2*.

✓ Alarm is selected (see previous steps 1 and 2).

- 11 Specify with ► or ▲ whether **Alarm x** is to be used as the **Alarm relay** or is to be **not used**. Confirm selection with SET and return to **Alarm x**.

- 12 Change to another alarm using ► or ▲ and perform settings in the same way.
- 13 Continue to **Main Menu Settings** using ► or ▲ or return to Measuring Mode by pressing ESC.

### 1.4.6.5 Editing Main Menu Settings

You can edit instrument settings and other settings.

In Measuring Mode, press SET, select **Main Menu Settings** using ► or ▲ and confirm selection with SET.

You can edit settings for:

Display

Language

H<sub>2</sub>O<sub>2</sub> proportion by weight entry (optional with 3rd analog output)

Unit: %

Absolute pressure unit

Selection: bar, psi, mPa, hPa

Absolute pressure

Unit as selected above.

Code

#### ➤ Editing display settings

You can set the brightness and contrast of the display.

- 1 Select **Display Settings** using ► or ▲ and confirm selection with SET.
- 2 Select **Backlight** or **Contrast** using ► or ▲ and confirm selection with SET.

One of the following parameters can now be selected using ► or ▲, after which the selection must be confirmed with SET:

#### **Backlight**

The display illumination is changed.

Edit/select parameter with ► or ▲, confirm with SET or cancel entry with ESC (the effect of the change in parameter can be seen during input).

#### **Contrast**

The brightness difference between the display background and the displayed values is changed.

Edit/select parameter with ► or ▲, confirm with SET or cancel entry with ESC (the effect of the change in parameter can be seen during input).

### Backlight on 24 h

Using ► or ▲ select **On** or **Off** and confirm with SET.

Off: The display light switches off automatically if no button was pressed for 30 seconds.

On: The display light is activated

- 3 Go back to **Display Settings** by pressing ESC and continue to **Language** using ► or ▲.

### ➤ Selecting language

You can select the language for the plain text line in the display.

Press SET, select required language with ► or ▲, confirm selection with SET and return to **Language**.



Only choose a language that you can understand well.

### ➤ Editing H<sub>2</sub>O<sub>2</sub> proportion by weight (optional with 3rd analog output)

This menu is only used to parameterize humidity measurements in H<sub>2</sub>O<sub>2</sub> atmospheres (e.g. in sterilization processes) and determines whether °Ctm or °Ftm is the output parameter.

This menu is only used to parameterize humidity measurements in H<sub>2</sub>O<sub>2</sub> atmospheres (e.g. in sterilization processes) and determines whether °Ctm, °Ftm or %rFm is the output parameter.

- 4 Select **H<sub>2</sub>O<sub>2</sub> Weight Proportion** using ► or ▲ and confirm selection with SET.

The selection **H<sub>2</sub>O<sub>2</sub> passively vaporized** or **H<sub>2</sub>O<sub>2</sub> actively vaporized** in the submenu describes whether H<sub>2</sub>O<sub>2</sub> is created through evaporation or is actively evaporated in the process.

- 5 Select **H<sub>2</sub>O<sub>2</sub> passively vaporized** or **H<sub>2</sub>O<sub>2</sub> actively vaporized** using ► or ▲ and confirm with SET.

- 6 Editing proportion by weight of H<sub>2</sub>O<sub>2</sub> in % (% H<sub>2</sub>O<sub>2</sub> proportion by weight in the liquid end solution): Scroll one digit to the right using ►, increase value of digit by 1 using ▲. Confirm with SET or abort entry with ESC.

- Using ESC return to **H<sub>2</sub>O<sub>2</sub> proportion by weight** and continue to **Absolute pressure unit** using ► or ▲.

➤ **Selecting absolute pressure unit (Abs. pressure unit)**

This parameter determines the humidity variables, standardised atmospheric dewpoint (°CtA, °FtA), relative humidity (g/kg or gr/lb) and water content (ppm<sub>vol</sub> or % vol).

- Press SET, select desired unit (selection: bar, psi, mPa, hPa) using ► or ▲ confirm selection with SET or cancel with ESC.
- Continue to **Absolute Pressure** with ► or ▲.

➤ **Editing absolute pressure (Abs. pressure value)**

You can set a value for the process absolute pressure.

- Using ► or ▲, select **Abs. pressure value** and confirm selection with SET.

The absolute pressure is displayed.

- Scroll one digit to the right using ►, increase value of digit by 1 using ▲. Confirm with SET or abort entry with ESC.
- Press SET and return to **Abs. pressure value**.
- Return to **Main Menu Settings** by pressing ESC.
- Continue to **Main Menu Analysis** using ► or ▲ or return to Measuring Mode by pressing ESC.

➤ **Editing code settings**

You can set the access code (password).



If a code other than "0000" (factory setting) is set, the transmitter can only be operated once this code has been entered via the menu.

- Select **Code** using ► or ▲ and confirm selection with SET.
- Scroll one digit to the right using ►, increase value of digit by 1 using ▲. Confirm with SET or abort entry with ESC.
- Return to **Code** by pressing ESC.

### 1.4.6.6 Editing Analysis main menu

You can test the functionality of analog and relay outputs. In addition, you can read off the minimum and maximum values (since the last voltage supply or reset of the min./max. values).

#### ➤ Testing functionality of analog outputs



This function affects the analog outputs directly, not only the test contacts.

- 1 In Measuring Mode, press SET, select **Main Menu Analysis** using ► or ▲ and confirm selection with SET.  
**Test Analog Output** is shown.
- 2 Press SET, choose between **Analog Output 1, 2, 3** with ► or ▲.
- 3 Press SET, scroll one digit to the right using ►, increase value of digit by 1 using ▲. Any analog output value can be predefined, e.g. for an analog output of 4 to 20 mA, the value "6.0 mA". Confirm with SET or abort entry with ESC.
- 4 Accept setting by pressing SET and test with multimeter (minimum requirement: resolution of 6.5 digits, accuracy of 100 nA):

Analog output 1 or 2: Via test contacts under service flap, see diagram.

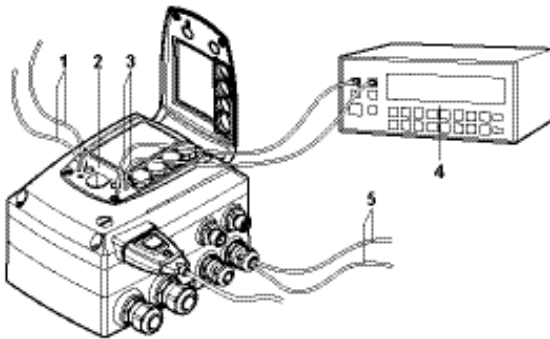

- 1 Channel 1 test contacts
- 2 Service interface
- 3 Channel 2 test contacts
- 4 Multimeter
- 5 Ends of channel 3 cables

Analog output 3: Connect measuring cables to terminals for channel 3, guide measuring cables out of housing and perform measurement outside of the transmitter, see diagram.

- 5 Return to **Test Analog Output** using ESC and continue to **Test Relay Output** using ► or ▲.

### ➤ Testing functionality of relay outputs

- 1 Press SET, choose between **Alarm 1, 2, 3, 4** with ► or ▲.
- 2 Press SET.

The relay can now be tested. You can choose between **OFF** and **ON** using ► or ▲. If **ON** is chosen, the NO contact is closed, the NC contact opened. If **OFF** is chosen, the NC contact is closed, the NO contact opened.

- 3 To test, route a measuring cable from the relay terminals (see *chapter 1.3.3.3*) out of the transmitter to a multimeter (resistance measurement) or continuity tester.
- 4 Return to **Test Relay Output** by pressing either SET (starts relay test) or ESC (exits the menu without relay test).

### ➤ Reading off min./max. values of channels



To reset the max./min. values, see *chapter 1.4.6.10*.

- 1 Read off the min./max. values of the three channels by pressing ► or ▲ one after the other and return to **Main Menu Analysis** using ESC.
- 2 Continue to **Main Menu Message** using ► or ▲ or return to Measuring Mode by pressing ESC.

#### 1.4.6.7 Editing Message main menu

Messages can be confirmed/acknowledged, the last messages can be called up and the display of the messages can be switched on or off.

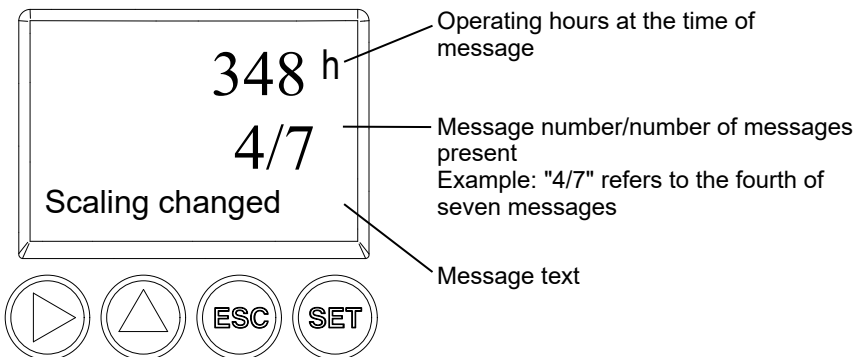



Using the P2A software (see *volume 2, chapter 3*) you can predefine which of the messages are to be shown in the display.

- 1 In Measuring Mode, press SET, select **Main Menu Message** using ► or ▲ and confirm selection with SET.
- 2 Confirm **Confirm message** using SET.
- 3 Select **Last messages** using ► or ▲ and confirm with SET.
- 4 Scroll between the messages recorded so far using ► or ▲ and press ESC to return to **Last messages**.
- 5 Continue to **Display of message** with ► or ▲.
  - ON:** Measurements are shown on the display in Measuring Mode.
  - OFF:** No messages shown on display.
- 6 Select **ON** or **OFF** using ► or ▲ and confirm selection with SET.
- 7 Return to **Main Menu Message** by pressing ESC.
- 8 Continue to **Main Menu Ident** using ► or ▲ or return to Measuring Mode by pressing ESC.



An overview of the messages can be found in *chapter 1.5, Status, warning and error messages*.

### 1.4.6.8 Calling up Main Menu Ident

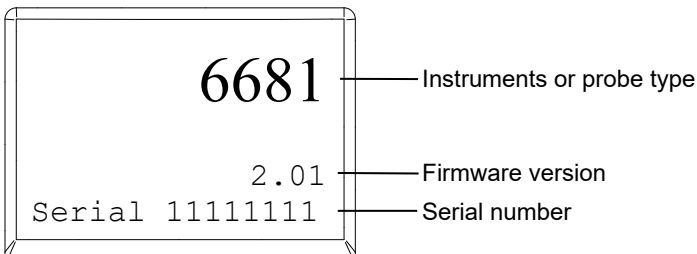

The serial numbers of the transmitter and probe can be read off.

- 1 In Measuring Mode, press SET, select **Main Menu Ident** using ► or ▲ and confirm selection with SET.

The type, firmware version and serial number of the transmitter are displayed.

- 2 Press ESC to return to the **Main Menu Ident** or read off the type, firmware version and serial number of the probe using ► or ▲ and then press ► or ▲ to return to the **Main Menu Ident**.
- 3 Continue to **Main Menu Adjustment** using ► or ▲ or return to Measuring Mode by pressing ESC.

### 1.4.6.9 Editing Adjust main menu

A reference value can be entered for both relative humidity (RH) and temperature (°C/°F) for the 1-point adjustment. Please refer to the description in *chapter 1.3.6.2*.

In addition, the analog outputs can be adjusted. See *chapter 1.3.6.4* for instructions on how to do this.



The 2-point adjustment for the adjustment points 20 %RH and 80 %RH is carried out via the user menu.

For the adjustment points 11.3 %RH and 75.3 %RH, the 2-point adjustment is carried out via the adjustment buttons or the P2A software, see *chapter 1.3.6.3* or *volume 2, chapter 3*.

#### ➤ Enter reference value for 1-point adjustment



Please also refer to *chapter 1.3.6.2*.

- 1 In Measuring Mode, press SET, select **Main Menu Adjust** using ► or ▲ and confirm selection with SET.  
**Reference value % RH** is displayed.
- 2 Press SET, edit value: Scroll one digit to the right using ►, increase value of digit by 1 using ▲. Confirm with SET or cancel entry with ESC.
- 3 Continue to **Reference value temp** with ► or ▲.
- 4 Press SET and **Reference value °C** is displayed.
- 5 Press SET, edit value: Scroll one digit to the right using ►, increase value of digit by 1 using ▲. Confirm with SET or abort entry with ESC.
- 6 Continue to **Reference value °F** with ► or ▲.



- 7 Press SET, edit value: Scroll one digit to the right using ►, increase value of digit by 1 using ▲. Confirm with SET or abort entry with ESC.
- 8 Continue to **Analog Adj. Ch. 1** with ► or ▲.
- 9 Continue with the adjustment of the analog outputs (see below, step 2) or press ESC to return to **Main Menu Adjustment**.
- 10 Continue to **Main Menu Reset** using ► or ▲ or return to Measuring Mode by pressing ESC.

➤ **Performing the 2-Points-Adjustment for 20% RH and 80 % RH**

- 1 In the Measuring Mode press SET, select **main menu Adjust** with ► or ▲ and confirm selection with SET.
- 2 Continue to **2Pt Adjust 20/80%** with ► or ▲.
- 3 Press SET.
- 4 Continue to **Adj. Point 20%** or **Adj. Point 80%** with ► or ▲
- 5 Confirm selection with SET.

The red LED ADJ flashes

In the display **2Pt Adjust 20/80%**, **1-point adjustment**, **Probe reset** appears consecutively.

The adjusted measurement values appear after probe reset.

➤ **Performing analog adjustment**



Please refer to *chapter 1.3.6.4*.

- 1 In Measuring Mode, press SET, select **Main Menu Adjust** using ► or ▲ and confirm selection with SET.



Each channel is adjusted at three points in the analog range (at 10 %; 50 %; 90°% of the analog scale).

- 2 Select **Analog Adj. Ch. 1** using ► or ▲ and confirm with SET.
- 3 Select **Adj. Point 1** using ► or ▲.
- 4 Press SET. Read off multimeter display (e.g. 5.601 mA) and enter this value in the user menu. Do this by scrolling one digit to the right using ► and increasing the value of digit by 1 using ▲. Confirm with SET or abort entry with ESC.

- 5 Select **Adj. Point 2** using ► or ▲.
- 6 Press SET. Read off multimeter display (e.g. 12.001 mA) and enter this value in the user menu. Do this by scrolling one digit to the right using ► and increasing the value of digit by 1 using ▲. Confirm with SET or abort entry with ESC.
- 7 Select **Adj. Point 3** using ► or ▲.
- 8 Press SET. Read off multimeter display (e.g. 18.401 mA) and enter this value in the user menu. Do this by scrolling one digit to the right using ► and increasing the value of digit by 1 using ▲. Confirm with SET or abort entry with ESC.
- 9 Continue to **Analog Adj. Ch. 2 or 3** with ► or ▲ (repeat steps 3 to 8).
- 10 Return to **Main Menu Adjust** by pressing ESC.
- 11 Continue to **Main Menu Reset** using ► or ▲ or return to Measuring Mode by pressing ESC.

#### 1.4.6.10 Editing Reset main menu

You can reset the factory settings for the following:

- Instrument
- Sensor/probe
- Min./max. values



Resetting to the factory settings means resetting to the order specification, i.e. the specific condition at the time of supply to the customer.

- 1 In Measuring Mode, press SET, select **Main Menu Reset** using ► or ▲ and confirm selection with SET.  
**Reset device** to factory settings is displayed.
- 2 Select the setting to be reset using ► or ▲ and confirm selection with SET.  
**Reset Completed** is displayed.
- 3 Press ESC or SET to return to reset setting and press ESC to return to **Main Menu Reset**.
- 4 Continue to **Main Menu Channel 1** using ► or ▲ or return to Measuring Mode by pressing ESC.

# 1.5 Status, warning and error messages



To achieve optimum operational reliability (machine availability), the transmitter provides the following via the user menu (see *chapter 1.4*) or the P2A software (see *volume 2, chapter 2*):

Status messages,  
Warning messages and  
Error messages

for either the testo 6681 or the connected testo 661x probe as applicable.

All messages are stored in the transmitter with an operating hours stamp. Use the user menu (see *chapter 1.4.6.7*) or P2A software (see *volume 2, chapter 2*) to view the message history.

In the transmitter, the last 160 messages are stored in a ring memory, but there is no restriction in the P2A software.

## 1.5.1 Status messages

Status messages show the current operating mode of the testo 6681.

Message	Display	Description
00300	New limit value	The limit value has been changed or shifted
00301	Scaling changed	The scaling has been changed
00500	Transmitter reset:	The transmitter was reset to the factory settings and is restarted.
0052F	Reset Min/Max	Resets all saved Min/Max values for all channels
02506	Probe connection	A probe has been connected
01D19	Service plug	The Mini-DIN socket is connected to: the USB adapter for P2A software, the adjustment adapter or the service plug (is not recorded/no number)
00307	User Setting Change	User Setting Change: General settings were changed for the transmitter.

Message	Display	Description
02d07	Probe disconnected	No probe is connected
02104	Analog out adjust	An analog adjustment has been made
02101	1-point adjustment	A 1-point adjustment is performed.
02102	2-point adjustment 11.3%	As part of the 2-point adjustment, an adjustment is performed at 11.3 % RH
02103	2-point adjustment 75.3%	As part of the 2-point adjustment, an adjustment is performed at 75.3 % RH
02120	2-point adjustment 20 %	As part of the 2-point adjustment, an adjustment is performed at 20 % RH
02130	2-point adjustment 80 %	As part of the 2-point adjustment, an adjustment is performed at 80 % RH
02105	Self-adjustment active	For testo 6615 probe only: The probe performs an automatic self-adjustment
02518	Probe reset	Probe reset: The probe performs a reset

## 1.5.2 Warning messages

Warning messages show an early warning or a current malfunction which may negatively impact measuring.

Message	Display	Cause	Remedying of fault
02101	2-point adjustment drift*	In the 2-point adjustment, corrections repeatedly occur in the same direction; this may indicate a sensor drift	Send the probe into Testo Service
00E00	T ambient high**	The ambient temperature exceeds the permissible temperature for the transmitter	Take necessary measures to lower ambient temperature, e.g. through venting or cooling
00E01	T ambient low**	The ambient temperature is below the permissible temperature for the transmitter	Take necessary measures to raise ambient temperature, e.g. through heating
00E02	Supply voltage low**	The supply voltage is below the minimum voltage required for the transmitter	Ensure sufficient voltage supply

Message	Display	Cause	Remedying of fault
00E00	T process high**	The process temperature exceeds the temperature designated for the probe	Remove the probe from the process and take any necessary measures to lower the process temperature
02806	Condensation*	100 % RH has been reached, condensation developing	Take measures to reduce process humidity
02807	Values less than 0 % RH**	The adjustment or sensor is faulty	Check adjustment (via P2A adjustment history, perform 2-point adjustment where necessary) If the problem persists, contact Testo Service
02809	Sensor early warning*	For testo 6617 probe only: The cover electrode of the sensor is damaged; this may soon cause the sensor to break	Carry out visual inspection If the mirror-like surface of the sensor is dirty or damaged, contact Testo Service

\* Early warning

\*\* Current malfunction

### 1.5.3 Transmitter error messages

Error messages show a current malfunction.

Message	Display	Cause	Remedying of fault
03401	No probe signal	The probe communication is interrupted	Ensure that the probe connector is fully engaged in the transmitter. If communication still cannot be established, contact Testo Service
03508	Wrong probe	The connected probe is not compatible with the present transmitter	Use a compatible probe Note: The 660x probes match the 665x transmitter, and the 661x probes the 668x transmitter
01528	Watchdog error	Due to a processor error, the transmitter performs an automatic restart	If the problem occurs frequently, contact Testo Service
0300A	% RH sensor short-circuit	Short-circuit in humidity sensor	Contact Testo Service
0300B	%RH sensor broken	The humidity sensor is damaged (sensor broken)	Contact Testo Service
0300C	T sensor short-circuit	Short-circuit in temperature sensor	Contact Testo Service
0300D	T sensor broken	The temperature sensor is damaged (sensor broken)	Contact Testo Service
03105	Self-adjustment error	For testo 6615 probe only: The automatic self-adjustment was faulty	Contact Testo Service

## 1.5.4 Status codes in cyclical service

### 1.5.4.1 Status codes for error messages

Message (Hexadecimal code)	Description	Cause
0x08	No communication	- No probe connected - Wrong probe connected - Communication with probe interrupted
0x10	No sensor signal	- Breakage of the sensor - Short-circuit humidity sensor - Short-circuit temperature sensor
0x0C	Transmitter malfunction	- Supply voltage to low - Ambient temperature to high - Ambient temperature to low - Transmitter is restarted

## 1.5.5 Handling alarm messages

Shown on the display <sup>1</sup>	Can be used for collective alarm <sup>2</sup>	Message start/end
Limit value	x	x
Scaling changed	x	x
Transmitter reset	x	x
Reset Min/Max		x
Transmitter refresh		x
Probe connection		
Service plug		
User Setting Change		x
Probe disconnected		
Analog out adjust		x
1-point adjustment	x	x
2-point adjustment 11.3%	x	x
2-point adjustment 75.3%	x	x
Probe self-adjustment	x	x
Probe reset	x	x

Shown on the display <sup>1</sup>	Can be used for collective alarm <sup>2</sup>	Message start/end
2-point adjustment drift*	x	
T ambient high**	x	
T ambient low**	x	
Supply voltage low**	x	
T process high**	x	
Condensation*	x	
Values less than 0 % RH**	x	
Sensor early warning*	x	
No probe signal	x	
Wrong probe		
Watchdog error	x	
% RH short-circuit	x	
%RH sensor broken	x	
T short-circuit	x	
T sensor broken	x	
Self-adjustment error		

- 1 If multiple messages/alarms are activated at the same time, only the last message/alarm is shown. If this is cancelled, the other messages that are still active are no longer displayed.
- 2 The message can be assigned the collective alarm function, which means that the collective alarm is activated as soon as at least one of the messages assigned to it is activated. The collective alarm can be assigned to each of the 4 optional relays. The collective alarm is then always the same, as it can only be defined once.

Execute **Confirm message** function (via control keys at transmitter):

- The message/alarm is no longer shown on the display. If multiple messages/alarms are active at the same time, all are reset simultaneously.
- If at least one message is assigned to the collective alarm, the collective alarm is reset. If the collective alarm is set on a relay, the relay is also reset, meaning switched to its neutral position.



## 1.5.6 Namur fault conditions

If the faults named in the following table occur, the analog outputs output special values that enable a general fault warning in the higher-level control system. The values correspond to the "Namur" industry standard.

Display message	Class	Analog output				
		0 - 20 mA	4 - 20 mA	1 V	5 V	10 V
No probe signal	Error	21 mA	21 mA	1.2 V	5.5 V	11 V
Wrong probe	Error	21 mA	21 mA	1.2 V	5.5 V	11 V
Watchdog error	Error	21 mA	21 mA	1.2 V	5.5 V	11 V
Values < 0 %RH	Underrange	0 mA	3.8 mA	0 V	0 V	0 V
Condensation	Overrange	20.5 mA	20.5 mA	1.2 V	5.5 V	11 V
%RH short-circuit	Error	21 mA	21 mA	1.2 V	5.5 V	11 V
%RH sensor broken	Error	21 mA	21 mA	1.2 V	5.5 V	11 V
T short-circuit	Error	21 mA	21 mA	1.2 V	5.5 V	11 V
T sensor broken	Error	21 mA	21 mA	1.2 V	5.5 V	11 V
Probe disconnected	Error	21 mA	21 mA	1.2 V	5.5 V	11 V

# 1.6 Maintenance and cleaning

## 1.6.1 Maintaining the instrument

We recommend that the adjustment and settings of the transmitter be checked at regular intervals using the

User menu (*chapter 1.4*) or  
P2A software (*volume 2, chapter 2*)

Convenient "remote monitoring" of the transmitter can be implemented, for example by using a relay as a collective alarm (see *chapter 1.4.6.4*) whose messages are forwarded to a local alarm transmitter (horn, light) or PLC.

## 1.6.2 Cleaning the instrument

Only clean the instrument carefully with a moist cloth.

Do not use aggressive cleaning agents.

Do not use any solvents

Do not touch or damage the sensor.



