



testo 6651 · Humidity transmitters

testo 6600 · Probes

P2A software · Parameterizing, adjusting and analyzing software

Instruction manual Volume 1

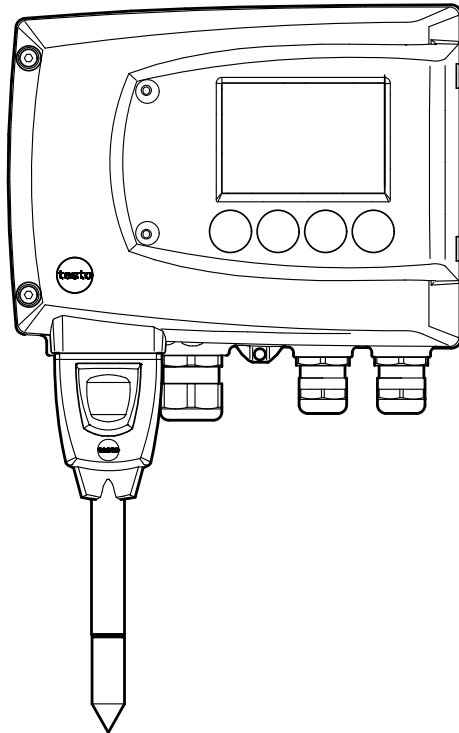

Safety and the environment

Avoiding electrical hazards

- ▶ Never use the instrument and connected probes to measure on or near live parts!
- ▶ Damaged mains cables must only be replaced by authorized personnel.
- ▶ Only have the transmitter wired and connected by authorized personnel with the voltage disconnected.
- ▶ You must always comply with the regulations applicable in your country to the opening and repair of electrical equipment.

Avoiding personal injury/damage to equipment

- ▶ Installation, setting and calibration work must only be carried out by qualified and authorized personnel!
- ▶ Only open the instrument when this is expressly described in the instruction manual for installation, maintenance or repair purposes.
- ▶ Observe the permissible storage, transport and operating temperatures.
- ▶ Never store or operate the product with solvents and do not use any desiccants.
- ▶ Do not use the instrument for control purposes at the same time as operating or servicing the transmitter.
- ▶ Only operate the product properly, for its intended purpose and within the parameters specified in the technical data. Do not use force.
- ▶ Carry out only the maintenance and repair work that is described in the documentation. Follow the prescribed steps when doing so. Use only OEM spare parts from Testo.

Any additional work must only be carried out by authorized personnel. Otherwise Testo will not accept any responsibility for the proper functioning of the instrument after repair and for the validity of certifications.

Protecting the environment

- ▶ Send the product back to Testo at the end of its useful life. We will ensure that it is disposed of in an environmentally friendly manner.

About this document

- ▶ Please read this documentation through carefully and familiarize yourself with the product before putting it to use. Keep this document to hand so that you can refer to it when necessary. Hand this documentation on to any subsequent users of the product.
- ▶ The following conventions are followed in this document:

Character/ display:	Explanation/example
------------------------	---------------------



With the signal word **Warning!**:

Warns against hazards which could result in serious physical injury if the precautionary measures indicated are not taken, e.g.:

De-energize the mains connection before connecting the transmitter!



With the signal word **Caution!**:

Warns against hazards which could result in minor physical injury or damage to equipment if the precautionary measures indicated are not taken, e.g.:

Observe the permissible operating temperature!



Important information, e.g.:

Administrator rights are required to install the program under Windows® 7, 8 and 10.

- Aim of action, e.g.:
 - **Assembling the instrument at the process connection:**
- ✓ Requirement that must be met, e.g.:
 - ✓ USB drivers are installed.

1 Steps are numbered if a certain sequence of actions must be followed, e.g.:

- 1 Loosen and remove housing screws.
- 2 Remove the upper part of housing.

▪ A step is not numbered if there are no further steps or if the step is optional, e.g.:

- Insert probe connector into socket of testo 6651 until it engages.

" ... " Example entries are in inverted commas, e.g.:

The value "0" results in

Bold type Elements of the program interface or instrument display, e.g.:

The instrument designation appears in the **instrument/parameter file list**.

Select **Main Menu Channel 1** and confirm with SET.

...>... Functions/paths within a menu, e.g.:

Start > All Programmes > Testo > Transmitter Software.

[] Buttons which start an action, e.g.:

Confirm the software key with [OK].

CAPITAL LETTERS Keys on the instrument or keypad, e.g.:

Press ESC.

Contents

1	TRANSMITTER.....	6
1.1	Specifications.....	6
1.1.1	Functions and use.....	6
1.1.2	Scope of delivery.....	6
1.1.3	Accessories.....	7
1.1.4	Technical data.....	7
1.1.5	Dimensions.....	9
1.2	Product description.....	10
1.2.1	At a glance.....	10
1.2.2	Usable probes.....	11
1.2.3	Display and keypad.....	12
1.2.4	Service interface.....	12
1.2.5	Relay board (option).....	12
1.2.6	Analog outputs.....	13
1.2.7	Parameters.....	13
1.2.8	Scaling.....	14
1.2.9	Alarm handling.....	16
1.3	Commissioning.....	17
1.3.1	Assembling the instrument.....	17
1.3.2	Connecting the instrument.....	21
1.3.3	Adjusting the instrument.....	32
1.4	Operation.....	37
1.4.1	Relationship between user menu and mini-DIN socket is active	37
1.4.2	Key cover.....	38
1.4.3	Password protection.....	38
1.4.4	Structure of user menu.....	39
1.4.5	Overview of the testo 6651 user menu.....	40
1.4.6	The individual main menus.....	42
1.5	Status, warning and error messages.....	53
1.5.1	Transmitter status messages.....	53
1.5.2	Transmitter warning messages.....	54
1.5.3	Transmitter error messages.....	55
1.5.4	Handling alarm messages.....	56
1.5.5	Namur fault conditions.....	58
1.6	Maintenance and cleaning.....	59
1.6.1	Maintaining the instrument.....	59
1.6.2	Cleaning the instrument.....	59

1 Transmitter

1.1 Specifications

1.1.1 Functions and use

The testo 6651 humidity transmitter is used in conjunction with plug-in, adjusted probes from the testo 6600 range.



Please refer to *volume 2, chapter 2* for information about commissioning, operating and maintaining the testo 6600 probe.

The testo 6651 humidity transmitter is suitable for the following applications, for example:

- Process instrumentation
- Test benches
- Production and storage air quality
- Complex room climate applications

1.1.2 Scope of delivery

The scope of delivery of the testo 6651 humidity transmitter includes the following:

- Key cover
- Rear panel bracket

1.1.3 Accessories

The following accessories are available for the testo 6651 humidity transmitter:

- Protection caps for probes
- Mains unit
- P2A software (parameterizing, adjusting and analyzing software)
- Assembly accessories.



Information about accessories and their order numbers can be found in *volume 2, chapter 4.2* or on the website at www.testo.com.

1.1.4 Technical data

Parameters

- Humidity (% RH/°Ctd/°Ftd)
- Temperature (°C/°F)

Measuring range

- Depends on probe

Accuracy

- Depends on probe

Resolution

- 0.1 % RH or 0.1 °C/0.1 °F

Meas. cycle

- 1/s

Interface

- Mini-DIN for P2A software (parameterizing and adjusting software) and handheld testo 400/650

Voltage supply

- 2-wire: 18 ... 24 V DC \pm 10%
- 4-wire (separate signal and supply lines):
20 - 30 V AC/DC,
300 mA power consumption

Maximum load

- 2-wire: 100 to 750 Ω

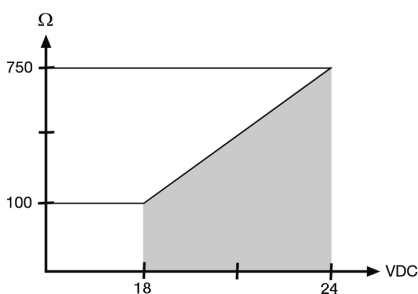

- 4-wire: 500 Ω (power output)

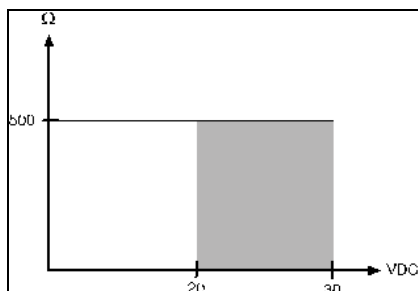

Analog output

- 4 ... 20 mA \pm 0.03 mA (2-wire) or
- 0 ... 1 V \pm 1.5 mV (4-wire) or
- 0 ... 5 V \pm 7,5 mV (4-wire) or
- 0 ... 10 V \pm 15 mV (4-wire) or
- 0 ... 20 mA \pm 0.03 mA (4-wire) or
- 4 ... 20 mA \pm 0.03 mA (4-wire)

Resolution of analog output

- 12 bit

Relay

- 4 relays, 250 V AC/DC, 3 A (optional)

Display

- 2-line LCD with plain text line (optional)

Housing operating temperature

- - 40 ... 70 °C/-40 to +158 °F, with display from 0 - 50 °C / 32 to +122 °F

Storage temperature

- - 20 ... 80 °C/-4 to +176 °F

Housing, weight

- Plastic, 675 g/1.49 lb

Protection class

- IP 65 only if the transmitter is wired and/or seal plugs are inserted

Directives, standards and tests

- EC Directive: 2014/30/EC

1.1.5 Dimensions

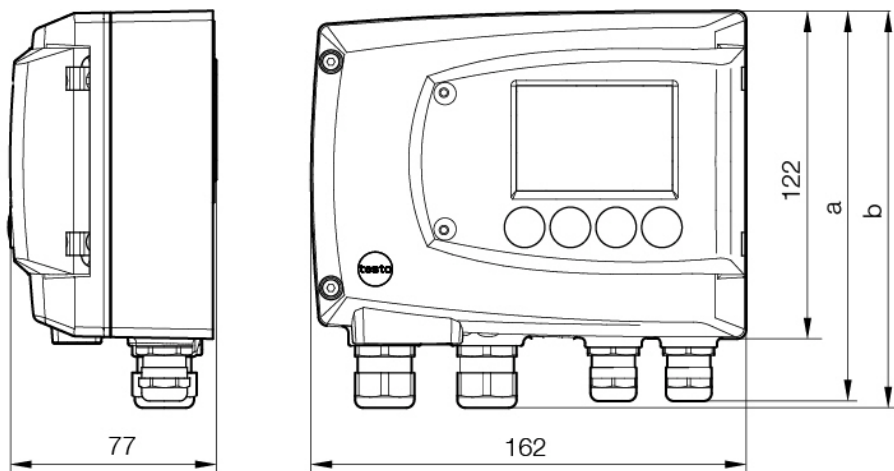

Dimensions in mm	a	b
With M 20 cable couplings	144	147
With NPT cable couplings	144	144
With plug-in connections	143	

1.2 Product description

1.2.1 At a glance

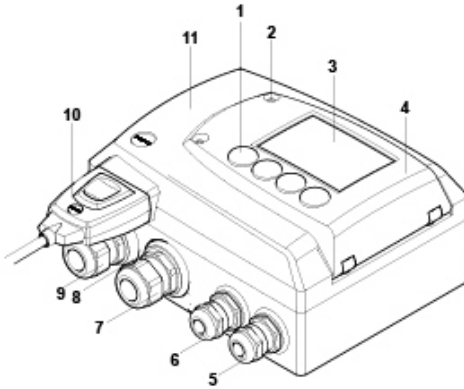

- 1 Keys (with optional display)
- 2 Service flap screw connection (self-locking, 2x)
- 3 Display (optional)
- 4 Service flap
- 5 M 16 x 1.5 screw connection*, e.g. analog outputs
- 6 M 16 x 1.5 screw connection*, e.g. voltage supply
- 7 M 20 x 1.5 screw connection*, e.g. relay R 3 and R 4
- 8 Eyelet for measuring point panel
- 9 M 20 x 1.5 screw connection*, e.g. relay R 1 and R 2
- 10 Probe connector (testo 6600)
- 11 Upper part of housing
- 12 Housing screws (M4 x 20 mm)
- 13 Socket for probe connector

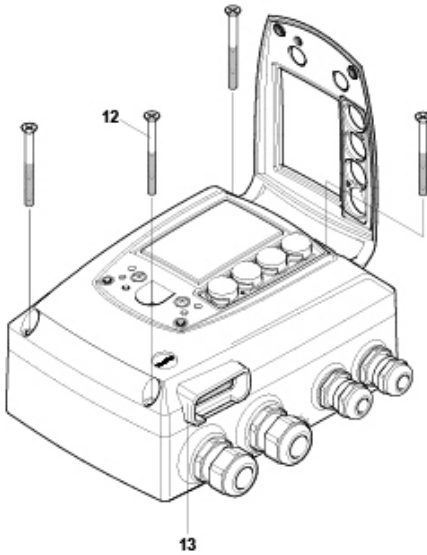

* Alternatively, NPT cable couplings or M plug-in connections are available

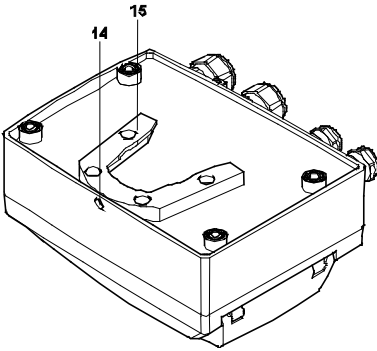

- 14 Hole for fastening to rear panel bracket (M3 x 6 screw)
- 15 Plastic bracket for assembly on rear panel

1.2.2 Usable probes

The testo 6651 humidity transmitter can be used with the following probes:

probe	Article no.	Characteristic
testo 6601	0555 6600-L01	Wall probe version; accuracy to ± 1.7 % RH; temperature range -20 °C to +70 °C/-4 to +158 °F
testo 6602	0555 6600-L02	Duct probe version; accuracy to ± 1.7 % RH; temperature range -20 °C to +70 °C/-4 to +158 °F
testo 6603	0555 6600-L03	Duct probe version; accuracy to ± 1.7 % RH; temperature range -30 °C to +120°C/-22 to +248 °F
testo 6604	0555 6600-L04	Cable probe version; accuracy to ± 1.7 % RH; temperature range -20 °C to +70 °C/-4 to +158 °F
testo 6605	0555 6600-L05	Cable probe version; accuracy to ± 1.7 % RH; temperature range -30 °C to +120°C/-22 to +248 °F

1.2.3 Display and keypad

The display option allows the testo 6651 humidity transmitter to be operated via the display and four keys.

The LCD display consists of two 7-segment lines for displaying readings and units and of an information line (for status messages, for example).

The brightness and contrast of the display and the background lighting (permanent or off) can be changed via the user menu or the P2A software.

1.2.4 Service interface

Behind the service flap is the parameterizing socket (mini-DIN) as an interface to the P2A software.

1.2.5 Relay board (option)

This has a floating switch capacity of 250 V AC/3 A. The switching limits and hysteresis as well as the function as relay for the collective alarm can be set via the display or the P2A software. Further features include:

- Function of changeover contacts (NC/NO contacts) freely selectable
- 12 terminals for a total of 4 relays.



If no relays are available, settings for monitoring limit values or alarms can still be controlled via the display.



Only have the transmitter wired and connected by authorized personnel with the voltage disconnected.

1.2.6 Analog outputs

For analog outputs, the testo 6651 has either

- 2 current outputs of 4 to 20 mA (2-wire)/0 to 20 mA (4-wire)/4 to 20 mA (4-wire) or
- 2 voltage outputs of 0 to 1 V/0 to 5 V/0 to 10 V (4-wire).

In 2-wire operation, channel 1 is used for the supply. The two channels are galvanically isolated in both 2- and 4-wire operation.



The relay option and the background lighting of the optional display are only possible in 4-wire operation.

1.2.7 Parameters

The following parameters are calculated:

- Relative humidity in % RH and (technical)
- Relative humidity in % WMO* (calculation according to the WMO standard)
- Temperature °C and °F
- Dewpoint in °Ctd and °Ftd.
- Absolute humidity in g/m³

*It is possible that condensation appears as of a displayed humidity starting from 70 % and is shown on the display. This unit is used in meteorology, for example. According to the WMO, the Magnus coefficient is used for sub-cooled water in the calculation of relative humidity.



Calculated humidity variables correspond to the medium of air. With other gases/gas compositions, deviations may occur, e.g. with the enthalpy

1.2.8 Scaling

There are three types of min./max. values:

1 The measuring range

The maximum sensor performance is in this range. Values outside of the measuring range are displayed via messages, for example.

Measuring range, see table (below).

2 Standard scaling

The output signals are assigned to this measuring range as standard:

- during delivery if no entries are made in the order code
- after exchanging the unit, the measuring range recorded in the instrument is applied as standard.



The transmitter even retains its scaling with the voltage disconnected.

Measuring range, see table (below).

3 The maximum settings for the manual scaling

- the values are not expressly given in the table. The maximum limits can be calculated as follows:

X = difference between MIN. and MAX. value of the standard scaling

(Max. value of standard) + (50 % of X)

(Min. value of standard) - (50 % of X)

- It is thus possible to scale beyond the measuring range, e.g. for the adjustment of the scaling limits to standard values of a PLC.
 However, the physical measurement range limits are the deciding factor when defining alarms.

Parameter	Unit	probe	Measuring range physical at 1013 hPa		Standard scaling MUF measuring range	
			MIN	MAX	MIN	MAX
Temperature	°C	6601, 6602, 6604	-20	+70	-20	+70
	°F	6601, 6602, 6604	-4	+158	-4	+158
	°C	6603, 6605	-30	+120	-30	+120
	°F	6603, 6605	-22	+248	-22	+248
relative humidity	% RH,		0	+100	0	+100
WMO relative humidity	% RH		0	+100	0	+100
Dewpoint at 25 °C T max	°Ctd	6601, 6602, 6604	-20	+70	-80	+100
	°Ftd	6601, 6602, 6604	-4	+158	-112	+212
	°Ctd	6603, 6605	-20	+100	-80	+100
	°Ftd	6603, 6605	-4	+212	-112	+212
Absolute humidity	g/m3	all probes	0	600	0	2000

1.2.9 Alarm handling

For upper and lower alarm limits, individual alarms as well as collective alarms can be specified. If the collective alarm function is activated, an alarm is triggered as soon as the alarm limit of an alarm is exceeded, if this alarm is assigned to the collective alarm.

The testo 6651 monitors limit values using relays. If a reading is outside the limit values, a relay to be specified by the user is switched.

If the reading reverts to more than a specified hysteresis below or above the limit value, the alarm is cancelled.

In addition, information about the occurrence of error/status messages can be provided by means of a collective alarm relay (see *chapter 1.5*).



If multiple alarm messages are activated at the same time, the last alarm is shown. If the alarm is cancelled again, the previous messages are no longer shown.



Example

If the condensation of the probe begins, the "Condensation" message appears on the display and the "Start" status display. If the condensation is over, the status display changes from "Start" to "End".

1.3 Commissioning

1.3.1 Assembling the instrument

1.3.1.1 Wall mounting (for testo 6601/6604/6605 probes)

➤ Attaching rear panel bracket

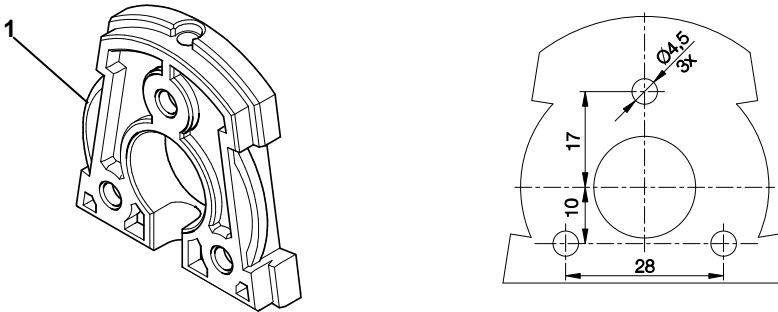

- 1 Remove locking screw (item **(4)** of drawing on page 18) and detach rear panel bracket from plastic bracket (item **(2)** of drawing on page 18).
- 2 Hold rear panel bracket in assembly position and mark the three drill holes.
- 3 Drill three holes (\varnothing 5 mm) and insert dowels where necessary.
- 4 Screw on rear panel bracket.
Remember that the clamping brackets **(1)** must face the wall.

➤ **Fastening instrument to rear panel bracket**

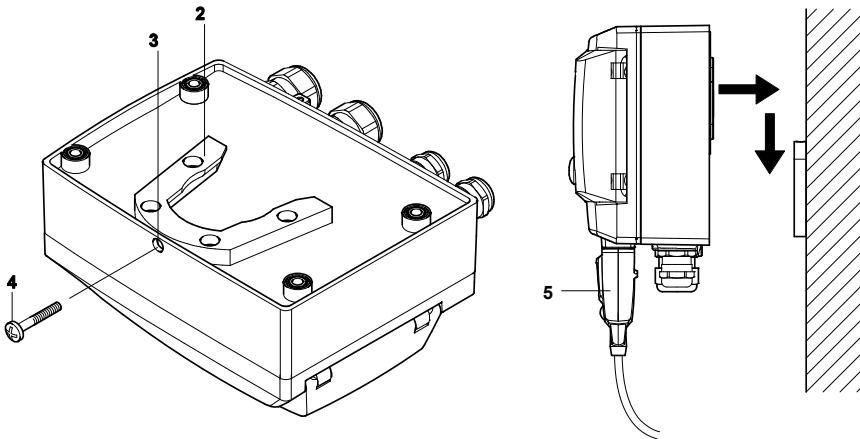

- 1 Slide plastic bracket **(2)** on the back of instrument onto rear panel bracket until it engages (see arrows).
- 2 Insert screw **(4)** through hole **(3)** and screw into rear panel bracket.
- 3 Insert probe connector **(5)** into socket until it engages.

1.3.1.2 Duct mounting (for testo 6602/6603 probes)

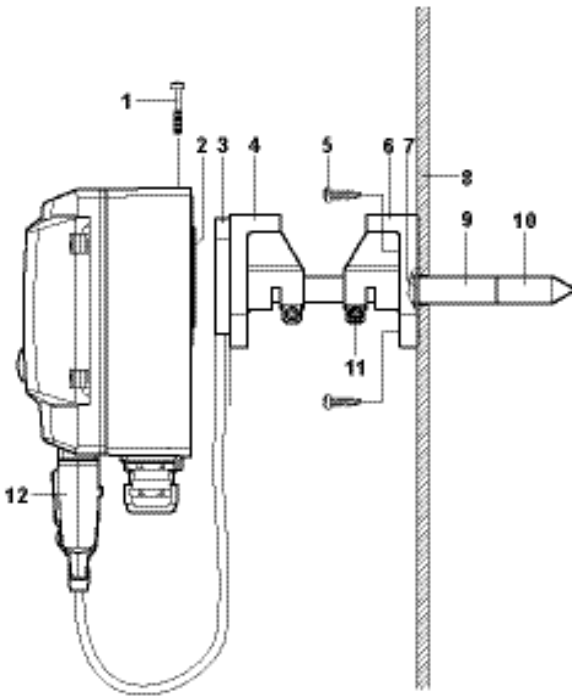

- 1 Hold wall/duct bracket (order no. 0554 6651) **(6)** against duct wall **(8)** and mark drill holes for wall/duct bracket and probe shaft.
- 2 Drill a hole (\varnothing 12.5 mm) in the duct wall to feed through the probe shaft.
- 3 Fasten wall/duct bracket **(6)** to duct wall with screws **(5)**.
- 4 Push probe shaft **(9)** with filter **(10)** through the middle hole of the mounting bracket.



The wall/duct bracket **(6)** has an O-ring **(7)** to seal it against the duct. Feed the probe shaft **(9)** carefully through the wall/duct bracket so that the O-ring is not damaged.

- 5 Fix the correct position of the probe shaft **(8)** with screw **(11)** and mark (insert probe shaft as far as possible).
- 6 Slide plastic bracket **(2)** on the back of the transmitter onto bracket **(3, 4)** until it engages.



Take the weight of the transmitter into account. Ensure that the brackets **(4, 6)** are fastened securely.

- 7 Insert screw **(1)** through hole on the top of the instrument and screw into bracket **(3)**.
- 8 Insert probe connector **(12)** into socket until it engages.

1.3.2 Connecting the instrument

➤ Opening the instrument

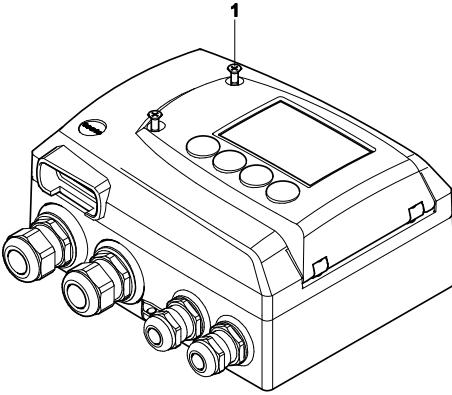

1 Loosen screw connection (1) of service flap and open the flap.

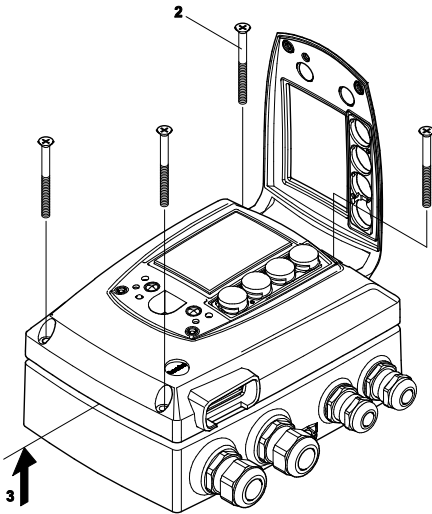

2 Loosen and remove housing screws (2).

3 Remove upper part of housing from lower part (3) and place on a clean surface.



Warning!

Electrical voltage.

Danger of injury!

De-energize the mains connection before connecting the transmitter!



Only have the transmitter wired and connected by authorized personnel with the voltage disconnected.

1.3.2.1 Overview of terminals

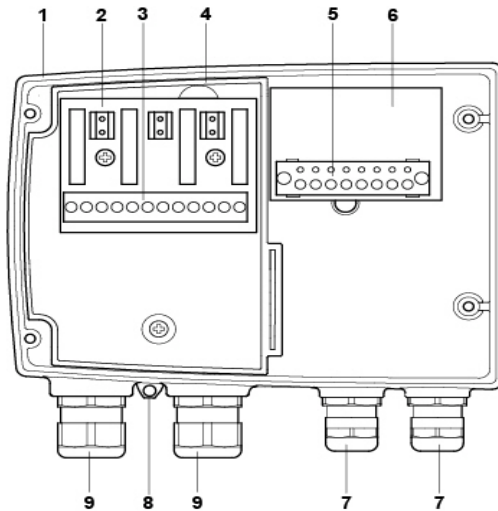

- 1 Lower part of housing
- 2 Relay board (option)
- 3 Relay terminals
- 4 Insulating trough for relay board
- 5 Terminal strip for voltage supply and analog outputs

- 6 Terminal board
- 7 M 16 x 1.5 screw connection*
- 8 Eyelet for measuring point panel
- 9 M 20 x 1.5 screw connection*
- * Alternatively, NPT cable coupling or M plug-in connection



The following description of the terminals refer to this overview and its numbering.

1.3.2.2 Connecting voltage supply and analog outputs



Terminal strip for voltage supply and analog outputs (item **(5)** of *Overview of terminals, chapter 1.3.2.1*).

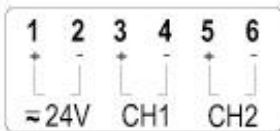

- 1 Feed cable with voltage supply and analog signal lines through opened M 16 x 1.5 screw connection (item **(7)** in *Overview of terminals, chapter 1.3.2.1*).
- 2 Strip the cable ends, clamp wire end ferrules on and screw down onto voltage terminals.
- 3 Close M 16 x 1.5 screw connection (item **(7)** in *Overview of terminals, chapter 1.3.2.1*).

Wiring diagram for 2-wire system (4 - 20 mA)

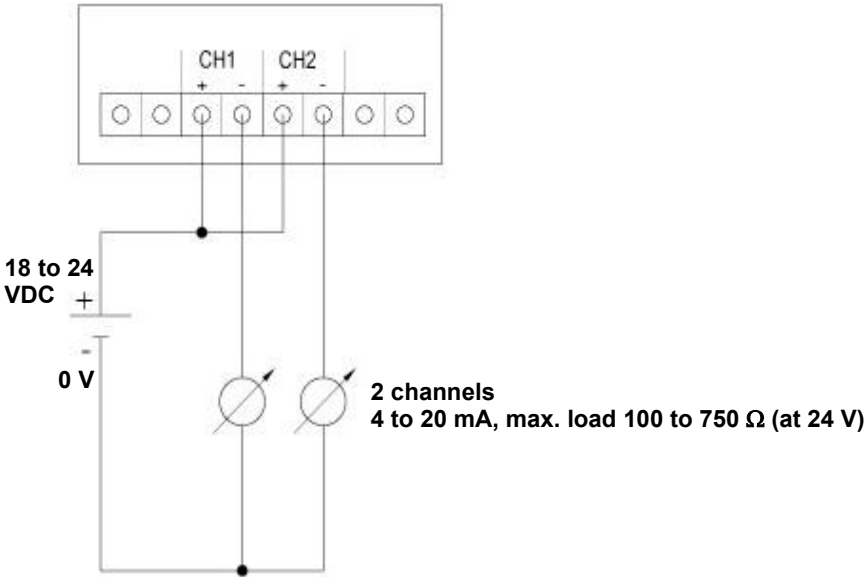

If the channels have to be galvanically isolated, a separate mains unit must be used for each channel.

**Wiring diagram for 4-wire system
(0 to 20 mA/4 to 20 mA/0 to 1 V/0 to 5 V/0 to 10 V)**

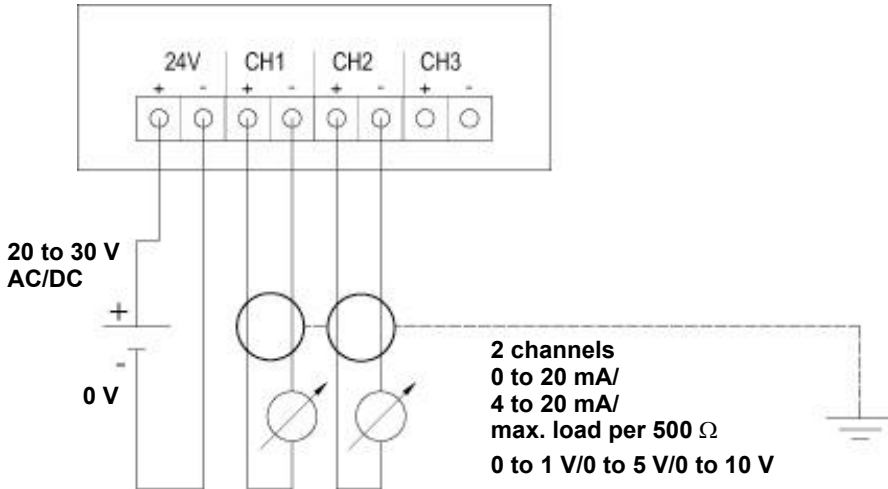

The channel 3 shown on the circuit board cannot be used with this instrument.



Requirement for the connecting cable of the supply:

- Insulated with cross-section of at least 0.25 sq. mm.
- The supply line must be secured against exceeding 8 A.
- An OFF switch must be installed in an easily accessible position close by and be marked as such.

- 1 Feed connection cables of the two channels through opened M 16 x 1.5 screw connection (item (7) of *Overview of terminals, chapter 1.3.2.1*).
- 2 Strip the cable ends, clamp wire end ferrules on and screw to channel terminals as shown in diagram.
- 3 Close M 16 x 1.5 screw connection (item (7) in *Overview of terminals, chapter 1.3.2.1*).

1.3.2.3 Connecting the relay outputs



Only have the transmitter wired and connected by authorized personnel with the voltage disconnected.

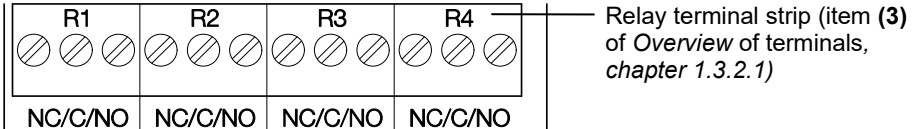

There is the option of twelve terminals for a total of four relays. The designations NC/C/NO (normally closed contact/root or pin/normally open contact) are etched on the surface of the board.

Using PG screw connection

- 4 Feed connection cables for the relays through opened M 20 x 1.5 screw connection (item (10) of Overview of terminals, chapter 1.3.2.1).
- 5 Strip cable ends and clamp on wire end ferrules.
- 6 Connect relays according to chosen function (NC/NO) (see diagrams below; relay 1 is shown as an example of a connection).

Using plug-in connections (optional)



Only insert or disconnect the plug-in connection when the voltage is disconnected.

- 1 Clean the connector of the probe line and the coupling of any foreign matter.



Do not disconnect the connector of the probe line from the instrument for extended periods to protect against contamination.

Connection note

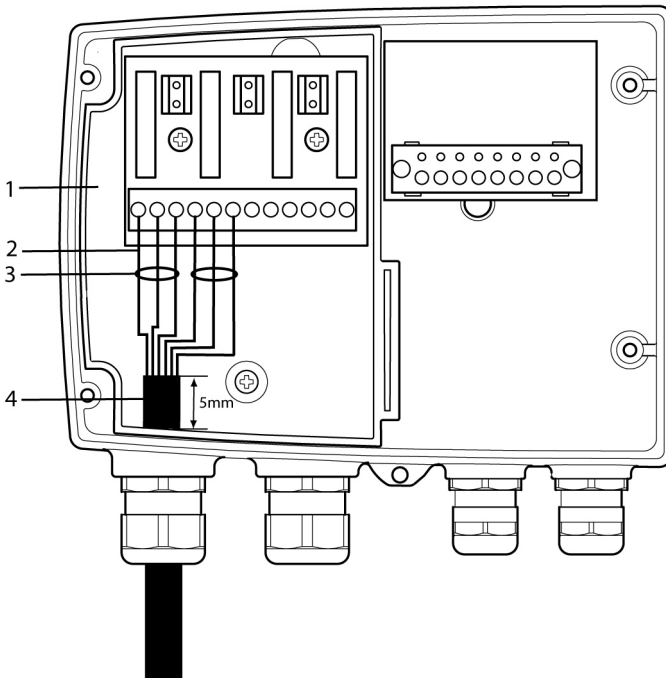

- For the connection, a double-insulated mains cable (sheathed cable) with a cross-section of at least 1.5 sq. mm must be used.
- Cable connection (2) may not be routed in a loop within the tray (1).
- It is recommended that you always tie 3 cores to one another using a cable tie (3).
- The insulation of the cable must be fed at least 5 mm (4) into the tray.

Use of relay as NC contact (NC = normally closed)

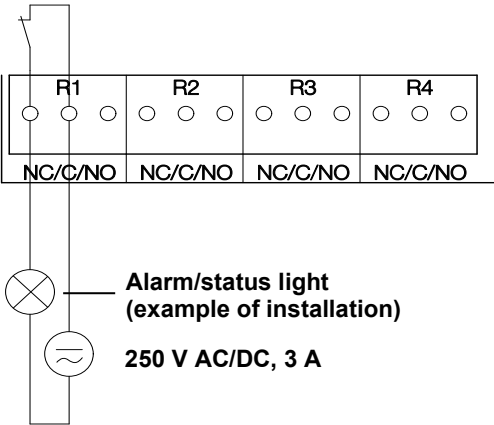

The busy light (alarm/status light) is permanently on until the relay opens or the circuit is interrupted. This circuit can therefore be used to monitor the functionality of the alarm circuit, as a cable break, for instance, is indicated by the busy light going off.

Use of relay as NO contact (NO = normally open)

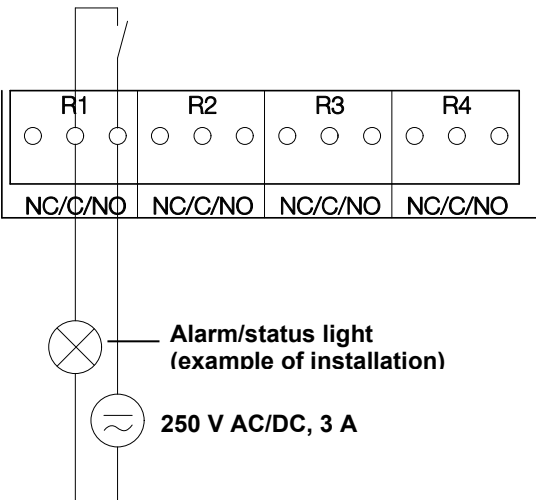



The busy light (alarm/status light) only comes on when the relay is switched (closed). Monitoring the functionality of the alarm circuit is therefore not possible with this switching operation.

- 2 Close M 20 x 1.5 screw connection (item **(9)** of *Overview of terminals, chapter 1.3.2.1*).

1.3.2.4 Plug-in connection option

As an option, the PG screw connections of the signal and supply lines can be replaced with plug-in connections that are installed at the housing (see Fig. 1 and 2). The relay cabling occurs via standard cable entries and PG screw connections, see Fig. 3 and 4

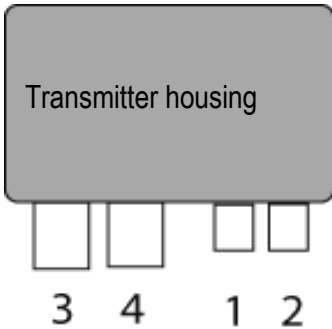

Plug-in connections for power supply and channels

M12 plug-in connection (5-pin) socket (1)

View of the plug-in connections in the installed state from outside



Pin	Assignment.
1	V 24 -
2	V 24 +
3	+ Ch 1
4	- Ch 1
5	PE

M12 plug-in connection (5-pin) connector (2)

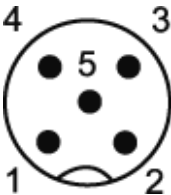

Pin	Assignment.
1	- Ch 2
2	+ Ch 2
3	+ Ch 3
4	- Ch 3
5	PE

1.3.2.5 Closing the instrument

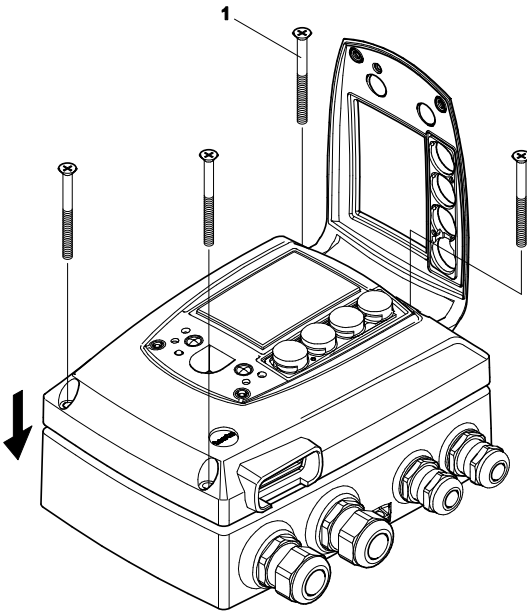

- 1 Place upper part of instrument on top of lower part (see arrow) and fix in place with housing screws (1).

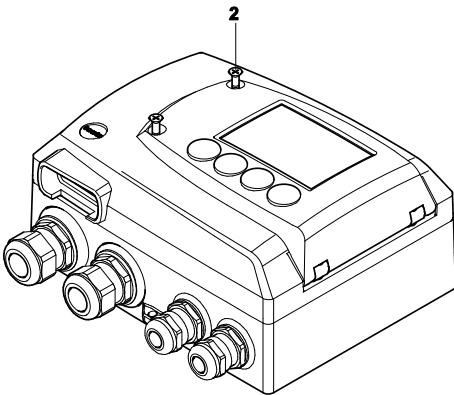

- 2 Close the service flap and tighten screws (2).

1.3.3 Adjusting the instrument

The testo adjusting concept allows the entire signal chain from the sensor signal (probe) and the digital signal (within the transmitter) through to the analog signal (transmitter output signal) to be adjusted (see diagram).

1-point adjustment

2-point adjustment

Analog adjustment

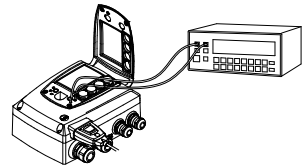
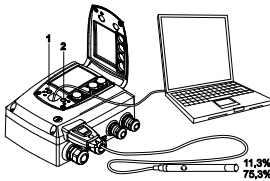

Adjustment via

- P2A software
- User menu

Adjustment 11.3 % RH and
75.3 % RH via

- Adjustment keys (1, 2)
 - P2A software
- Adjustment 20 % rH and
80 % rH via
- User menu

Adjustment using a precise
multimeter and transmission
of analog reference value in

- P2A software or
- User menu

Either the 1-point adjustment or 2-point adjustment is suitable for adjusting the sensor signal - digital signal chain.

The testo 6651 transmitter has digital probes whose adjustment information is stored in the probe's internal memory. Both 1-point and 2-point adjustments can thus be carried out on another testo 6651 (e.g. in the calibration laboratory).

1.3.3.1 Overview: Adjustment keys and test contacts

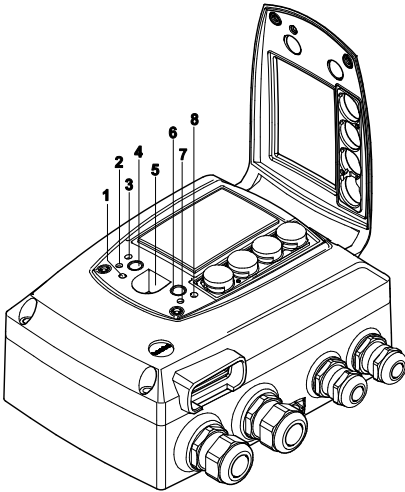

- 1 LED
- 2 Contact ch. 1 +
- 3 Contact ch. 1 -
- 4 Adjust key 11.3 %
- 5 Service interface
- 6 Adjust key 75.3 %
- 7 Contact ch. 2 +
- 8 Contact ch. 2 -

1.3.3.2 1-point adjustment (offset)

In the 1-point adjustment, the reading at the working point is raised to the reference value so that there is no longer any deviation in the working point. The reference condition can be measured using a precise reference instrument or be created in an air conditioning cabinet.

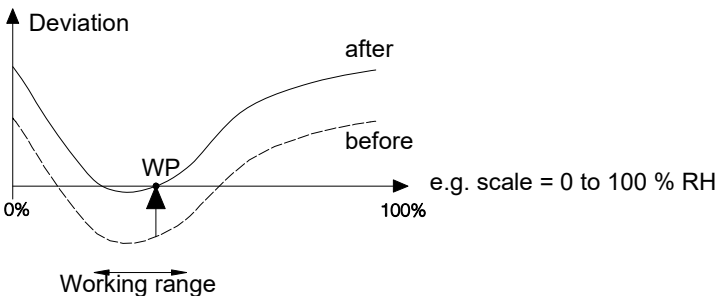

The advantage of the 1-point adjustment is the good measuring result in the working range. But the further away the measurement is from the working point, the greater the deviation can become. The 1-point adjustment should therefore only be used for a relatively narrow measuring range (working range), e.g. clean room applications, air conditioning applications for storage and similar.

The 1-point adjustment can be performed

- via the user menu (see *chapter 1.4.6.8*) or
- via the P2A software (see *volume 2, Chapter 3*)



Please note that the 1-point adjustment is generally performed on the basis of the % RH and °C/°F parameters.

1.3.3.3 2-point adjustment

With the 2-point adjustment, the parameter is adjusted to the reference value at the two standard adjustment points 11.3 % RH and 75.3 % RH or 20 % RH and 80 % RH. The reference conditions are created either by using Testo humidity adjustment set (order no. 0554 0660, only for adjustment points 11.3 %RH and 75.3 %RH) or in the humidity generator.

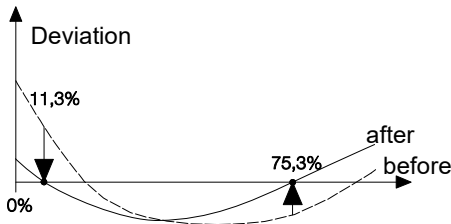

In the 2-point adjustment, the deviations between the reading and the nominal value are minimized across the entire measuring range. The 2-point adjustment is therefore recommended for large working ranges, e.g. in drying processes.

The 2-point adjustment can be performed for the adjustment points 11.3 %RH and 75.3 %RH

- via P2A software (see *volume 2, chapter 3*) or
- using the adjustment keys under the service flap, see description of how to proceed below.

The 2-point adjustment for the adjustment points 20 %RH and 80 %RH is carried out via the user menu.



A 2-point adjustment cancels any previous 1-point adjustment.

➤ **Adjusting testo 6651 using adjustment keys**



The 2-point adjustment for the adjustment points 20 %RH and 80 %RH is carried out via the user menu.

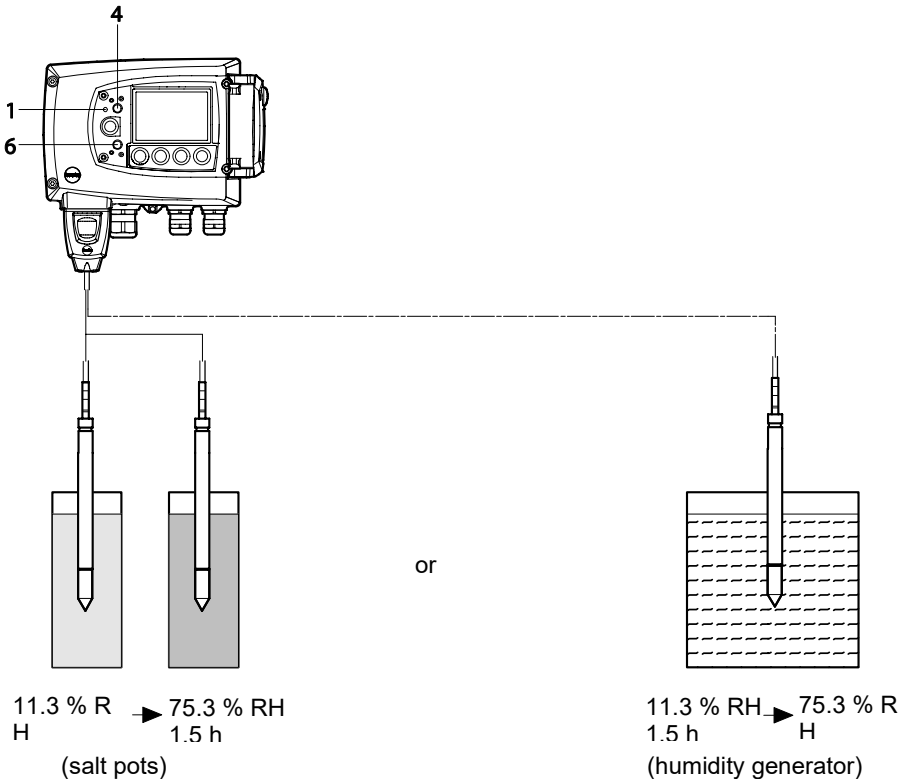

✓ The service flap of the testo 6651 is open.

- 1 Expose the humidity probe of the testo 6651 to the reference condition of 11.3 % RH for at least 1.5 hours at 25 °C.
- 2 After this equalization period, press the 11.3 % adjustment key **(4)** for at least 10 seconds with something like a ball-point pen that is not too sharp. The LED **(1)** flashes when the adjustment process begins. At the same time, the **2-point adjustment 11.3 %** status message appears on the display
 - Completion of the adjustment is signalled by the LED **(1)** coming on permanently and the **Probe reset** status message is shown.
- Carry out the adjustment analogously for the reference condition 75.3 % RH. Press on the 75.3 % RH adjustment key **(6)** to do this.
- 3 Close the service flap.

1.3.3.4 Analog output adjustment

The purpose of adjusting the analog outputs is to adjust the signal chain from the digital signal (within the transmitter) to the analog outputs. The signal type that was appointed for the transmitter is adjusted respectively for each channel (e.g. 4 to 20 mA or 0 to 1 V, etc.).

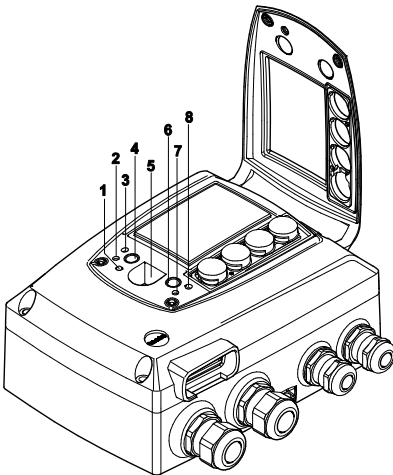

- 1 LED
- 2 Contact ch. 1 +
- 3 Contact ch. 1 -
- 4 Adjust key 11.3 %
- 5 Service interface
- 6 Adjust key 75,3 %
- 7 Contact ch. 2 +
- 8 Contact ch. 2 -

➤ Adjust analog outputs

- ✓ A precise multimeter (minimum resolution of 6.5 digits, accuracy of 100 μ A, e.g. Agilent 34401A) is available.



If only a simple multimeter is available, the analog outputs may not be adjusted.

- ✓ The service flap is open.
- 1 Connect the inputs of the multimeter with the contacts **(2)** and **(3)** for channel 1 or with contacts **(7)** and **(8)** for channel 2.
 - 2 Transfer the reference analog value measured with the multimeter to the P2A software (see *volume 2, chapter 3*) or enter it via the user menu (see *chapter 1.4.6.8*).
 - 3 Disconnect connections between multimeter and contacts of the testo 6651 and close service flap.

1.4 Operation

1.4.1 Relationship between user menu and mini-DIN socket is active

The testo 6651 can be parameterized using either the user menu or the P2A software (see *volume 2, chapter 3*).



The testo 6651 humidity transmitter can only be operated via the display and keypad if the display option is available.

If the testo 6651 is connected to the P2A software, the user menu is blocked for the duration of the communication. The message **Service plug** is shown in the display of the testo 6651. As soon as the P2A software is disconnected, the user menu is accessible again.

1.4.2 Key cover

To prevent unauthorized operation of the keys, the standard key frame can be replaced with a key cover.

If the key cover has been assembled, the service flap must be opened for operation (see Section *Opening the instrument, chapter 1.3.2*).

➤ Attaching the key cover

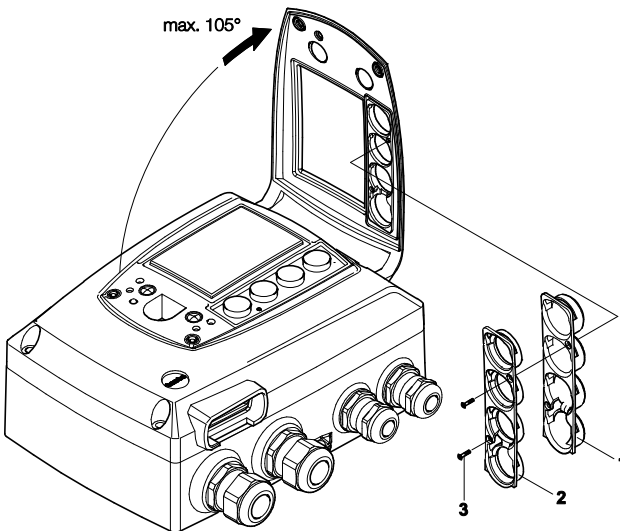

✓ The service flap is open (see Section *Opening the instrument, chapter 1.3.2*).

- 1 Undo screws (3) and remove key frame (2).
- 2 Insert key cover (1) into service flap and tighten screws (3).
- 3 Close and screw down the service flap.

1.4.3 Password protection

The user menu can be protected with a four-digit numerical code (see *chapter 1.4.6.4*) so that access to the user menu is denied to unauthorized persons not familiar with this numerical code.

If the password protection is not to be used, the numerical code "0000" must be entered. This is also the status upon delivery.

1.4.4 Structure of user menu

At the main menu level, the user menu comprises the following:

- **Main menu of channel 1**
- **Main menu of channel 2**
- **Main Menu Alarm**
- **Editing Settings main menu**
- **Analysis main menu**
- **Status main menu**
- **Ident main menu**
- **Adjustment main menu**
- **Reset main menu**

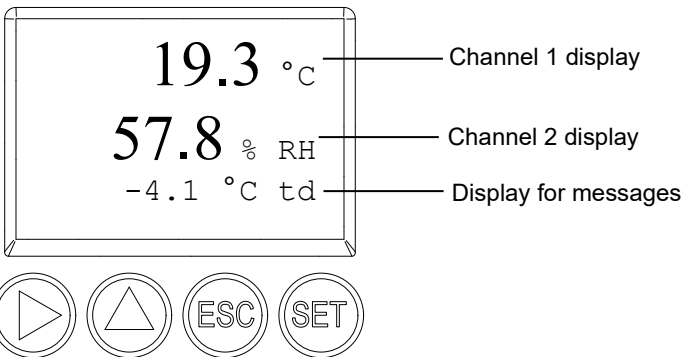

Four keys enable the user to navigate/scroll through the menus and enter/amend values and settings:

Key	Function/description
SET	- In Measuring Mode: changes to parameterization - In Parameterizing Mode: confirms a selection or setting
ESC	- Leaves a menu (without modifying any settings)
▶	- Selecting: scrolls through menus (downwards) or selectable alternatives - Editing: changes to next digit (to the right)
▲	- Selecting: scrolls through menus (upwards) or selectable alternatives - Editing: increases the value of the current digit by 1

1.4.5 Overview of the testo 6651 user menu

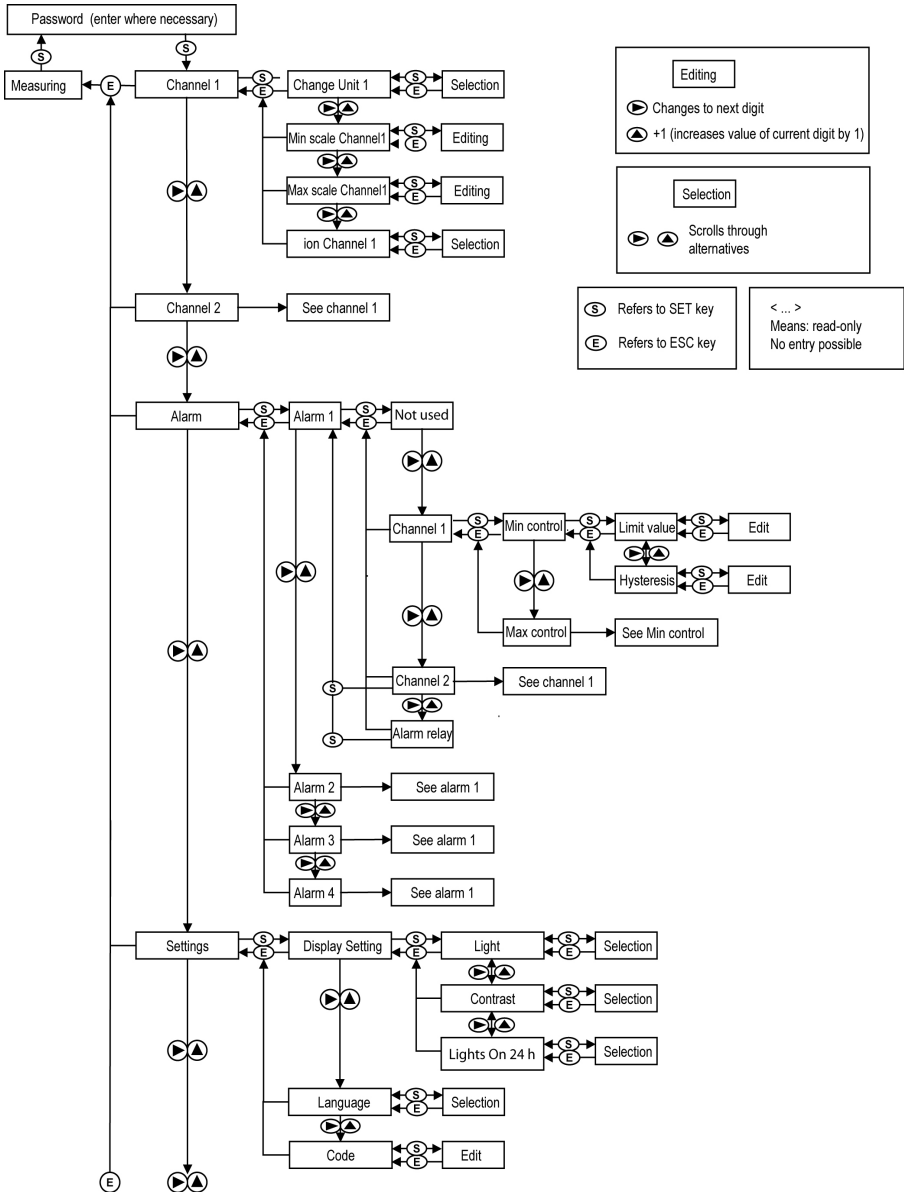

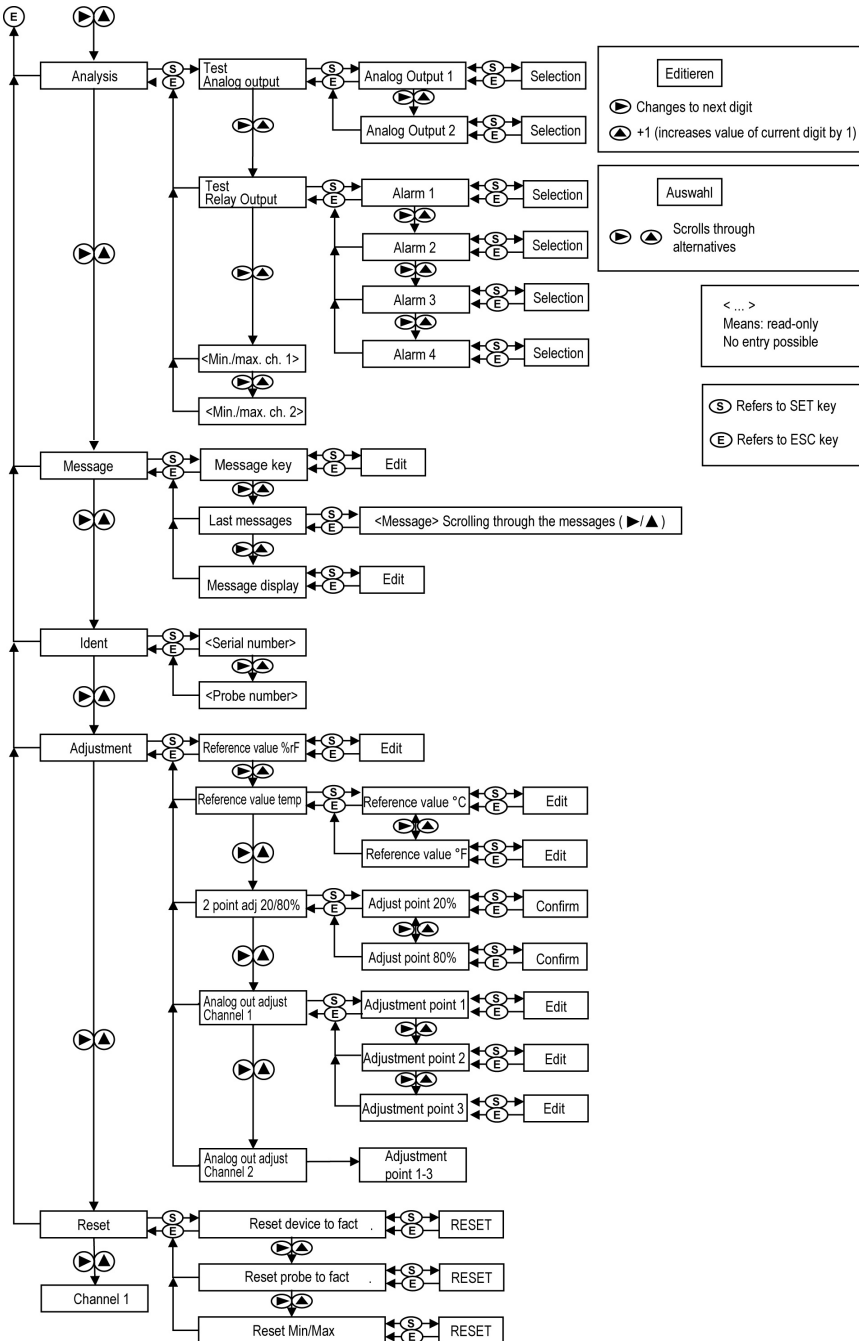

1.4.6 The individual main menus

1.4.6.1 Editing Main Menu Channel 1

An overview is given in *Overview of the testo 6651 user menu* (see chapter 1.4.5).

You can perform basic settings for channel 1.

- 1 In Measuring Mode, press SET, select **Main Menu Channel 1** using ► or ▲ and confirm selection with SET.

One of the following parameters can now be selected using ► or ▲, after which the selection must be confirmed with SET:

- **Channel 1 unit**

The parameter for this channel is selected.

Selection: % RH, °C, °F, °Ctd, °Ftd, g/m³.

Edit/select parameter with ► or ▲, confirm with SET or abort input with ESC.

- **Scale minimum for channel 1**

The lower scale limit is edited;

Unit as selected above (example: 4 mA = 0 % RH).

Editing the value: Scroll one digit to the right using ►, increase value of digit by 1 using ▲. Confirm with SET or abort entry with ESC.

- **Scale maximum for channel 1**

The upper scale limit is edited;

Unit as selected above (example: 20 mA = 100 % RH).

Editing the value: Scroll one digit to the right using ►, increase value of digit by 1 using ▲. Confirm with SET or abort entry with ESC.

- **Signal delay ("Damping")for channel 1**

The analog signal can be delayed ("Damping"); a time constant is selected for this (1 = no delay; 15 = longest delay).

Edit/select parameter using ► or ▲, confirm with SET or cancel entry via ESC.

- 2 Continue to **Main Menu Channel 2** using ► or ▲ or return to Measuring Mode by pressing ESC.

1.4.6.2 Editing main menu of channel 2

See channel 1.

1.4.6.3 Editing Main Menu Alarm

With the alarm, the relays, available as options, are programmed. In addition, the alarm statuses are shown on the display (top right) (even without relays). You can choose whether the alarm is used to monitor limit values or as a collective alarm. If an alarm is to be used to monitor limit values, you can choose between monitoring the minimum or maximum value and set a limit value and hysteresis for each alarm.

- 3 In Measuring Mode, press SET, select **Main Menu Alarm** using ► or ▲ and confirm selection with SET.

Four alarms can be parameterized.

- 4 Select **Alarm x** using ► or ▲ and confirm selection with SET.

➤ **Using alarm to monitor limit values**

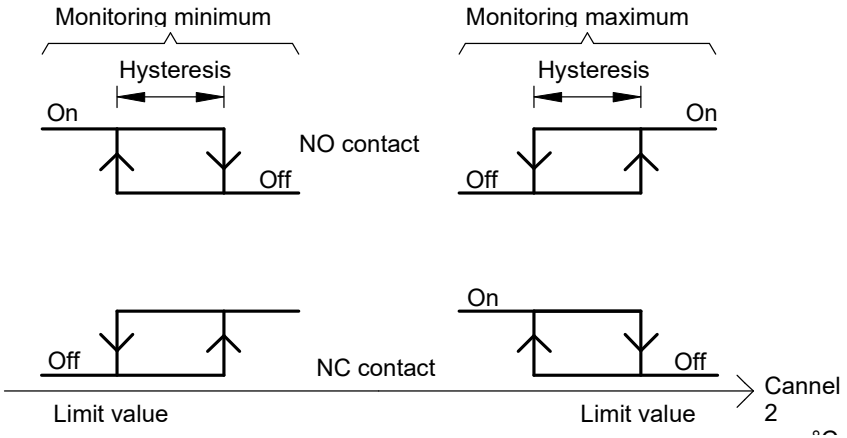

- 5 Select **Channel x** (e.g. "Channel 1") using ► or ▲ and confirm selection with SET.
- 6 Select **Max control** or **Min control** with ► or ▲ (see graphic).
- 7 Press SET and edit **limit value** and **hysteresis**: Scroll one digit to the right using ►, increase value of digit by 1 using ▲. Confirm with SET or abort entry with ESC.
- 8 Return to **Channel x** by pressing ESC.
- 9 Return to **Alarm x** by pressing ESC.
- 10 Change to the other relays using ► or ▲ and perform settings in the same way.

➤ Using alarm as collective alarm or not using it at all

If the collective alarm is assigned to an alarm, the relay is switched as soon as (at least) one of the warning or error messages of the testo 6681 transmitter (or the connected testo 6610 probe) is activated.



Note:

The messages affecting the collective alarm can be selected in the P2A software (see *volume 2, chapter 3*).

✓ Alarm is selected (see previous steps 1 and 2).

- 1 Specify with ► or ▲ whether **Alarm x** is to be used as the **Alarm relay** or is **not to be used**. Confirm selection with SET and return to **Alarm x**.
- 2 Change to another alarm using ► or ▲ and perform settings in the same way.
- 3 Continue to **Main Menu Settings** using ► or ▲ or return to Measuring Mode by pressing ESC.

1.4.6.4 Editing Main Menu Settings

You can edit instrument settings and other settings.

- In Measuring Mode, press SET, select **Main Menu Settings** using ► or ▲ and confirm selection with SET.

You can edit settings for:

- Display
- Language
- Code.

➤ Editing display settings

You can set the brightness and contrast of the display.

- 1 Select **Display Settings** using ► or ▲ and confirm selection with SET.
- 2 Select **Backlight**, **Contrast** or **Backlight on 24 h** using ► or ▲ and confirm selection using SET.

One of the following parameters can now be selected using ► or ▲, after which the selection must be confirmed with SET:

- **Backlight**

The display illumination is changed.

Edit/select parameter with ► or ▲, confirm with SET or cancel entry with ESC (the effect of the change in parameter can be seen during input).

- **Contrast**

The brightness difference between the display background and the displayed values is changed.

Edit/select parameter with ► or ▲, confirm with SET or cancel entry with ESC (the effect of the change in parameter can be seen during input).

- **Backlight on 24 h**

Using ► or ▲ select **On** or **Off** and confirm with SET.

Off: The display light switches off automatically if no button was pressed for 30 seconds.

On: The display light is activated

3 Go back to **Display Settings** by pressing ESC and continue to **Language** using ► or ▲.

➤ **Selecting language**

You can select the language for the plain text line in the display.

- Press SET, select required language with ► or ▲, confirm selection with SET and return to **Language**.



Only choose a language that you can understand well.

➤ Editing code settings

You can set the access code (password).



If a code other than "0000" (factory setting) is set, the transmitter can only be operated once this code has been entered via the menu.

- 1 Select **Code** using ► or ▲ and confirm selection with SET.
- 2 Scroll one digit to the right using ►, increase value of digit by 1 using ▲. Confirm with SET or abort entry with ESC.
- 3 Continue to **Main Menu Analysis** using ► or ▲ or return to Measuring Mode by pressing ESC.

1.4.6.5 Editing Analysis main menu

You can test the functionality of analog and relay outputs. In addition, you can read off the minimum and maximum readings (since the last voltage supply or reset of the min./max. values).

➤ Testing functionality of analog outputs



This function affects the analog outputs directly, not only the test contacts.

- 1 In Measuring Mode, press SET, select **Main menu analysis** using ► or ▲ and confirm selection using SET.
Test Analog Output is shown. Any analog output value can be predefined, e.g. for an analog output of 4 to 20 mA, the value "6.0 mA".
- 2 Press SET, choose between **Analog Output 1, 2** with ► or ▲.
- 3 Press SET, scroll one digit to the right using ►, increase value of digit by 1 using ▲. Confirm with SET or abort entry with ESC.
- 4 Adopt the settings using SET and test with the multimeter at the test contacts below the service flap (minimum requirement: resolution of 6.5 digits, accuracy of 100 nA):

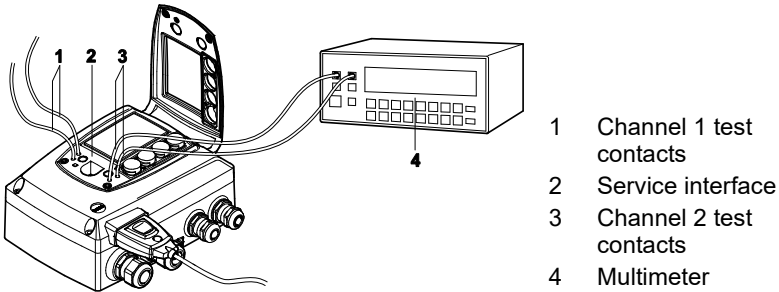

- 5 Return to **Test Analog Output** using ESC and continue to **Test Relaisausgang** using ► or ▲.

➤ **Testing functionality of relay outputs**

- 1 Press SET, choose between **Alarm 1, 2, 3, 4** with ► or ▲.
2 Press SET.

The relay can now be tested. You can choose between **OFF** and **ON** using ► or ▲. If **ON** is chosen, the NO contact is closed, the NC contact opened. If **OFF** is chosen, the NC contact is closed, the NO contact opened.

- 3 To test, route a measuring cable from the relay terminals (see *chapter 1.3.2.3*) out of the transmitter to a multimeter (resistance measurement) or continuity tester.
4 Go back to **Test Relay Output** by pressing either SET (starts relay test) or ESC (exits the menu without relay test).

➤ **Reading off min./max. values of channels**



To reset the max./min. values, see *chapter 1.4.6.9, Editing Reset main menu*.

- 1 Read off the min./max. values of the two channels in succession by pressing ► or ▲ and return to **Main Menu Analysis** using ESC.
2 Continue to **Main Menu Message** using ► or ▲ or return to Measuring Mode by pressing ESC.

1.4.6.6 Editing Message main menu

The last messages can be called up and the display of the messages can be switched on or off.

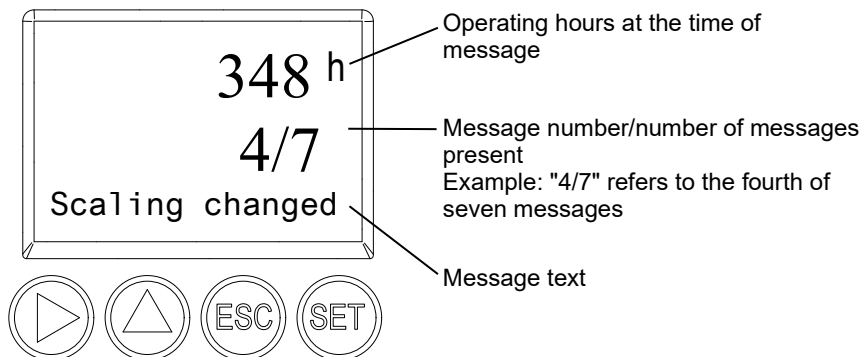

Using the P2A software (see *volume 2, chapter 3.3.2*) you can predefine which of the messages are to be shown in the display.

- 1 In Measuring Mode, press SET, select **Main Menu Message** using ► or ▲ and confirm selection with SET.
- 2 Confirm **Confirm message** using SET.
- 3 Select **Last messages** using ► or ▲ and confirm with SET.
- 4 Scroll between the messages recorded so far using ► or ▲ and press ESC to return to **Last messages**.
- 5 Continue to **Display of message** with ► or ▲.
 - ON:** Measurements are shown on the display in Measuring Mode.
 - OFF:** No messages shown on display.
- 6 Select **ON** or **OFF** using ► or ▲ and confirm selection with SET.
- 7 Return to **Main Menu Message** by pressing ESC.
- 8 Continue to **Main Menu Ident** using ► or ▲ or return to Measuring Mode by pressing ESC.



An overview of the messages can be found in *chapter 1.5, Status, warning and error messages*.

1.4.6.7 Calling up Main Menu Ident

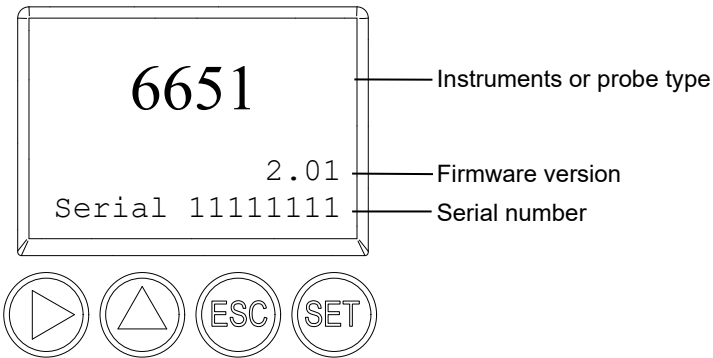

The serial numbers of the transmitter and probe can be read off.

- 1 In Measuring Mode, press SET, select **Main Menu Ident** using ► or ▲ and confirm selection with SET.

The type, firmware version and serial number of the transmitter are displayed.

- 2 Press ESC to return to the **Main Menu Ident** or read off the type, firmware version and serial number of the probe using ► or ▲ and then press ► or ▲ to return to the **Main Menu Ident**.
- 3 Continue to **Main Menu Adjustment** using ► or ▲ or return to Measuring Mode by pressing ESC.

1.4.6.8 Editing Adjust main menu

A reference value can be entered for both relative humidity (% RH) and temperature (°C/°F) for the 1-point adjustment. Please refer to the description in *Chapter 1.3.3.2, 1-point adjustment (offset)*.

In addition, the analog outputs can be adjusted. See *Chapter 1.3.3.4, Analog output adjustment* how to do this.



The 2-point adjustment for the adjustment points 20 %RH and 80 %RH is carried out via the user menu.

For the adjustment points 11.3 %RH and 75.3 %RH, the 2-point adjustment is carried out via the adjustment buttons or the P2A software (see *chapter 1.3.3.3 or volume 2, chapter 3.3.2*).

➤ **Enter reference value for 1-point adjustment**



Please also refer to *chapter 1.3.3.2, 1-point adjustment (offset)*.

- 1 In Measuring Mode, press SET, select **Main Menu Adjust** using ► or ▲ and confirm selection with SET.
Reference value % RH is displayed.
- 2 Press SET, edit value: Scroll one digit to the right using ►, increase value of digit by 1 using ▲. Confirm with SET or cancel entry with ESC.
- 3 Continue to **Reference value temp** with ► or ▲.
- 4 Press SET and **Reference value °C** is displayed.
- 5 Press SET, edit value: Scroll one digit to the right using ►, increase value of digit by 1 using ▲. Confirm with SET or abort entry with ESC.
- 6 Continue to **Reference value °F** with ► or ▲.
- 7 Press SET, edit value: Scroll one digit to the right using ►, increase value of digit by 1 using ▲. Confirm with SET or abort entry with ESC.
- 8 Continue to **Analog Adj. Ch. 1** with ► or ▲.
- 9 Continue with the adjustment of the analog outputs (see below, step 2) or press ESC to return to **Main Menu Adjustment**.
- 10 Continue to **Main Menu Reset** using ► or ▲ or return to Measuring Mode by pressing ESC.

➤ **Performing the 2-Points-Adjustment for 20% RH and 80 % RH**

- 1 In the Measuring Mode press SET, select **main menu Adjust** with ► or ▲ and confirm selection with SET.
- 2 Continue to 2Pt Adjust 20/80% with ► or ▲.
- 3 Press SET.
- 4 Continue to Adj. Point 20% or Adj. Point 80% with ► or ▲
- 5 Confirm selection with SET.
- 6 The red LED ADJ flashes

In the display 2Pt Adjust 20/80%, 1-point adjustment, Probe reset appears consecutively.

The adjusted measurement values appear after probe reset.

➤ Performing analog adjustment



Please refer to *chapter 1.3.3.4*.

- 1 In Measuring Mode, press SET, select **Main Menu Adjust** using ► or ▲ and confirm selection with SET.



Each channel is adjusted at three points in the analog range (at 10 %; 50 %; 90% of the analog scale).

- 2 Select **Analog Adj. Ch. 1** using ► or ▲ and confirm with SET.
- 3 Select **Adj. Point 1** using ► or ▲.
- 4 Press SET. Read off multimeter display (e.g. 5.601 mA) and enter this value in the user menu. Do this by scrolling one digit to the right using ► and increasing the value of digit by 1 using ▲. Confirm with SET or abort entry with ESC.
- 5 Select **Adj. Point 2** using ► or ▲.
- 6 Press SET. Read off multimeter display (e.g. 12,001 mA) and enter this value in the user menu. Do this by scrolling one digit to the right using ► and increasing the value of digit by 1 using ▲. Confirm with SET or abort entry with ESC.
- 7 Select **Adj. Point 3** using ► or ▲.
- 8 Press SET. Read off multimeter display (e.g. 18,401 mA) and enter this value in the user menu. Do this by scrolling one digit to the right using ► and increasing the value of digit by 1 using ▲. Confirm with SET or abort entry with ESC.
- 9 Continue to **Analog Adj. Ch. 2** with ► or ▲ (repeat steps 3 to 8).
- 10 Return to **Main Menu Adjust** by pressing ESC.
- 11 Continue to **Main Menu Reset** using ► or ▲ or return to Measuring Mode by pressing ESC.

1.4.6.9 Editing Reset main menu

You can reset the factory settings for the following:

- Instrument
- Sensor/probe
- Min./max. values



Resetting to the factory settings means resetting to the order specification, i.e. the specific condition at the time of supply to the customer.

- 1 In Measuring Mode, press SET, select **Main Menu Reset** using ► or ▲ and confirm selection with SET.
Reset device to factory settings is displayed.
- 2 Select the setting to be reset using ► or ▲ and confirm selection with SET.
Reset Completed is displayed.
- 3 Press ESC or SET to return to reset setting and press ESC to return to **Main Menu Reset**.
- 4 Continue to **Main Menu Channel 1** using ► or ▲ or return to Measuring Mode by pressing ESC.

1.5 Status, warning and error messages



To achieve optimum operational reliability (machine availability), the transmitter provides the following via the user menu (see *chapter 1.4*) or the P2A software (see *volume 2, Chapter 3*):

- Status messages,
- Warning messages and
- Error messages

for either the testo 6651 or the connected testo 660x probe as applicable.

All messages are stored in the transmitter with an operating hours stamp. Use the user menu (see *Chapter 1.4.6.6, page 48*) or P2A software (see *volume 2, chapter 3, page 89*) to view the message history.

In the transmitter, the last 180 messages are stored in a ring memory, but there is no restriction in the P2A software.

1.5.1 Transmitter status messages

Status messages show the current operating mode of the testo 6651.

Message	Display	Description
00300	New limit value	The limit value has been changed or shifted
00301	Scaling changed	The scaling has been changed
00500	Transmitter reset:	The transmitter is reset to the factory settings and is restarted.
0052F	Reset Min/Max	Resets all saved Min/Max values for all channels
02506	Probe connection	A probe has been connected
01D19	Service plug	The Mini-DIN socket is connected to: the USB adapter for P2A software, the adjustment adapter or the service plug (is not recorded/no number)
00307	User Setting Change	User Setting Change: General settings were changed for the transmitter.

Message	Display	Description
02d07	Probe disconnected	No probe is connected
02104	Analog out adjust	An analog adjustment has been made
02101	1-point adjustment	A 1-point adjustment is performed.
02102	2-point adjustment 11,3%	As part of the 2-point adjustment, an adjustment is performed at 11.3 % RH
02103	2-point adjustment 75.3%	As part of the 2-point adjustment, an adjustment is performed at 75.3 % RH
02120	2-point adjustment 20 %	As part of the 2-point adjustment, an adjustment is performed at 20 % RH
02130	2-point adjustment 80 %	As part of the 2-point adjustment, an adjustment is performed at 80 % RH
02518	Probe reset	Probe reset: The probe performs a reset

1.5.2 Transmitter warning messages

Warning messages show an early warning or a current malfunction which may negatively impact measuring.

Message	Display	Cause	Remedying of fault
02101	2-point adjustment drift*	In the 2-point adjustment, corrections repeatedly occur in the same direction; this may indicate a sensor drift	Send the probe into Testo Service
00E00	T ambient high**	The ambient temperature exceeds the permissible temperature for the transmitter	Take necessary measures to lower ambient temperature, e.g. through venting or cooling
00E01	T ambient low**	The ambient temperature is below the permissible temperature for the transmitter	Take necessary measures to raise ambient temperature, e.g. through heating
00E02	Supply voltage low**	The supply voltage is below the minimum voltage required for the transmitter	Ensure sufficient voltage supply

Message	Display	Cause	Remedying of fault
00E00	T process high**	The process temperature exceeds the temperature designated for the probe	Remove the probe from the process and take any necessary measures to lower the process temperature
02806	Condensation*	100 % RH has been reached, condensation developing	Take measures to reduce process humidity
02807	Values less than 0 % RH**	The adjustment or sensor is faulty	Check adjustment (via P2A adjustment history, perform 2-point adjustment where necessary) If the problem persists, contact Testo Service

* Early warning

** Current malfunction

1.5.3 Transmitter error messages

Error messages show a current malfunction.

Message	Display	Cause	Remedying of fault
03401	No probe signal	The probe communication is interrupted	Ensure that the probe connector is fully engaged in the transmitter. - If communication still cannot be established, contact Testo Service
03508	Wrong probe	The connected probe is not compatible with the present transmitter	Use a compatible probe Note: The 660x probes match the 665x transmitter, and the 661x probes the 668x transmitter
01528	Watchdog error	Due to a processor error, the transmitter performs an automatic restart	If the problem occurs frequently, contact Testo Service

Message	Display	Cause	Remedying of fault
0300A	% RH sensor short-circuit	Short-circuit in humidity sensor	Contact Testo Service
0300B	%RH sensor broken	The humidity sensor is damaged (sensor broken)	Contact Testo Service
0300C	T sensor short-circuit	Short-circuit in temperature sensor	Contact Testo Service
0300D	T sensor broken	The temperature sensor is damaged (sensor broken)	Contact Testo Service

1.5.4 Handling alarm messages

Shown on the display ¹	Can be used for collective alarm ²	Message start/end
Limit value	x	x
Scaling changed	x	x
Transmitter reset	x	x
Reset Min/Max		x
Transmitter refresh		x
Probe connection		
Service plug		
User Setting Change		x
Probe disconnected		
Analog out adjust	x	x
1-point adjustment:	x	x
2-point adjustment 11,3%	x	x
2-point adjustment 75.3%	x	x
Probe reset	x	x
2-point adjustment drift*	x	
T ambient high**	x	
T ambient low**	x	
Supply voltage low**	x	

Shown on the display ¹	Can be used for collective alarm ²	Message start/end
T process high**	x	
Condensation*:	x	
Values less than 0 % RH**	x	
No probe signal	x	
Wrong probe		
Watchdog error	x	
% RH sensor short-circuit	x	
%RH sensor broken	x	
T sensor short-circuit	x	
T sensor broken	x	

1 If multiple messages/alarms are activated at the same time, only the last message/alarm is shown. If this is cancelled, the other messages that are still active are no longer displayed.

2 The message can be assigned the collective alarm function, which means that the collective alarm is activated as soon as at least one of the messages assigned to it is activated. The collective alarm can be assigned to each of the 4 optional relays. The collective alarm is then always the same, as it can only be defined once.

Execute **Confirm message** function (via control keys at transmitter):

- The message/alarm is no longer shown on the display. If multiple messages/alarms are active at the same time, all are reset simultaneously.
- If at least one message is assigned to the collective alarm, the collective alarm is reset. If the collective alarm is set on a relay, the relay is also reset, meaning switched to its neutral position.

1.5.5 Namur fault conditions

If the faults named in the following table occur, the analog outputs output special values that enable a general fault warning in the higher-level control system. The values correspond to the "Namur" industry standard.

Display message	Class	Analog output				
		0-20mA	4-20mA	1V	5V	10V
No probe signal	Error	21mA	21mA	1.2V	5.5V	11V
Wrong probe	Error	21mA	21mA	1.2V	5.5V	11V
Watchdog error	Error	21mA	21mA	1.2V	5.5V	11V
Values < 0 %RH	Underrange	0mA	3.8mA	0V	0V	0V
Condensation	Overrange	20.5mA	20.5mA	1.2V	5.5V	11V
%RH short-circuit	Error	21mA	21mA	1.2V	5.5V	11V
%RH sensor broken	Error	21mA	21mA	1.2V	5.5V	11V
T short-circuit	Error	21mA	21mA	1.2V	5.5V	11V
T sensor broken	Error	21mA	21mA	1.2V	5.5V	11V
Probe disconnected	Error	21mA	21mA	1.2V	5.5V	11V

1.6 Maintenance and cleaning

1.6.1 Maintaining the instrument

We recommend that the adjustment and settings of the transmitter be checked at regular intervals using the

- User menu (see *chapter 1.4*) or
- P2A software (see *volume 2, chapter 3*)

Convenient "remote monitoring" of the transmitter can be implemented, for example by using a relay as a collective alarm (see *chapter 1.4.6.3*) whose messages are forwarded to a local alarm transmitter (horn, light) or PLC.

1.6.2 Cleaning the instrument

- Only clean the instrument carefully with a moist cloth.
- Do not use aggressive cleaning agents.
- Do not use any solvents.
- Do not touch or damage the sensor



Testo SE & Co. KGaA

Celsiusstr. 2

79822 Titisee-Neustadt

Germany

Tel.: +49 7653 681-0

E-Mail: info@testo.de

www.testo.com



testo 6651 · Humidity transmitters

testo 6600 · Probes

P2A software · Parameterizing, adjusting and analyzing software

Instruction manual Volume 2

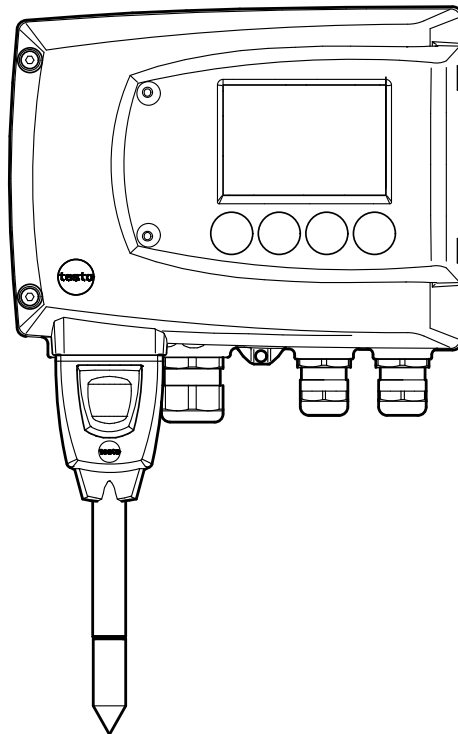

Contents

2	TESTEO 6600 PROBES	62
2.1	Specifications.....	63
2.1.1	Functions and use.....	63
2.1.2	Probe assembly	65
2.1.3	Accessories.....	66
2.2	Product description	66
2.2.1	Overview of probe and filter types	66
2.2.2	testo 6601 wall probe.....	69
2.2.3	testo 6602/6603 duct probe	73
2.2.4	testo 6604/6605 cable probe	78
2.3	Commissioning	81
2.3.1	Installing the probe.....	81
2.3.2	Connecting/removing the probe to/from the transmitter	83
2.4	Maintenance and cleaning.....	84
2.4.1	Replacing filters/protection caps.....	84
2.4.2	Cleaning the instrument and filter/protection cap	87
2.4.3	Replacing the sensors	87
3	PARAMETERIZING, ADJUSTING AND ANALYZING SOFTWARE (P2A SOFTWARE)	89
3.1	Specifications.....	89
3.1.1	Functions and use.....	89
3.1.2	System requirements	90
3.1.3	Scope of delivery.....	91
3.2	First steps	91
3.2.1	Installing the software/driver	91
3.2.2	Starting the software	92
3.3	Using the software	93
3.3.1	User interface.....	93
3.3.2	Editing instrument/parameter file	95
3.3.3	Analyzing/testing the transmitter.....	104
3.3.4	Adjusting the transmitter	109
3.3.5	Transmitter history	114
4	TIPS AND ASSISTANCE	120
4.1	Questions and answers	120
4.2	Accessories and spare parts	121
4.2.1	Ordering options for testo 6651 transmitter (0555 6651).....	123
4.2.2	Ordering options for testo 6600 probes (0555 6600).....	125

2 testo 6600 probes

2.1 Specifications

2.1.1 Functions and use

The plug-in, adjusted probes from the testo 6600 range are used in conjunction with the testo 6651 humidity transmitter.

These measuring units are suitable for the following applications, for example:

- Process instrumentation
- Test benches
- Production and storage air quality
- Complex room climate applications

2.1.1.1 Digital probes:

The probes are adjusted in the factory and transmit their adjustment data to the internal memory of the testo 6651 transmitter. The information is transmitted between the probe and transmitter in a purely digital form. The probes can therefore be disconnected from the transmitter for adjustment or servicing while the transmitter itself can remain at the measuring point.



Hint:

We recommend in this case that a probe of the same type be inserted into the transmitter immediately in order to be able to continue measuring with minimal interruption.

The transmitter identifies the probe and records that a probe was connected in the history.



The testo 6651 transmitter cannot be run with the testo 6610 probes; testo 6600 probes must be used.

2.1.1.2 The Testo humidity sensor

With the Testo humidity sensor, which has been in successful use and continually improved for more than ten years, the focus has from the very beginning been on both accuracy parameters, namely measuring uncertainty and long-term stability.

The capacitive humidity sensor is in principle a plate capacitor consisting of two electrically conductive plates (electrodes **(1)** and **(2)**, see diagram below) opposite each other.

A humidity-sensitive polymer (**5**) serves as the dielectric. The special feature lies in the perfect way the individual layers are matched to each other. This is evident particularly in the top electrode, which has to perform two tasks that, at first glance, appear contradictory: it must be completely permeable to the water vapour that is to be fed into the polymer dielectric, but at the same time it must be impervious, smooth and repellent to condensate, oil and dirt in order to protect the sensor.

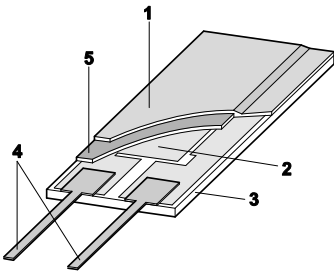

- 1 Cover electrode
- 2 Bottom electrode
- 3 Substrate
(Ceramic substrate for
mechanical protection)
- 4 Connections
(protected against corrosion)
- 5 Dielectric layer

2.1.1.3 Self-diagnosis

The probes in the testo 6600 range monitor their functionality themselves and report the following faults:

- Sensor breaks
- Sensor short-circuit
- Condensation

The condensation message is issued at a reading of 100 % RH and deactivated once the readings are within the valid range.
- Error message with drift at the adjustment points
- Value for relative humidity less than 0 % RH.

The trigger threshold is set at -2 % RH. This means that an error message is only issued once a clear effect is discernible.
- Adjustment monitoring with and without PC
- Operating hours
- Excess temperature

Error message if the permissible process temperature is exceeded

2.1.2 Probe assembly

The probes of the testo 6600 range are made up of the following components (included in delivery):

- Probe connector
- Probe shaft with protection cap and sensors (% RH and °C or °F)
- Mounting bracket (for testo 6602/6603 duct version)
- Probe cable (testo 6602 to 6605 duct and cable versions), bend radius minimum \varnothing 50 mm.

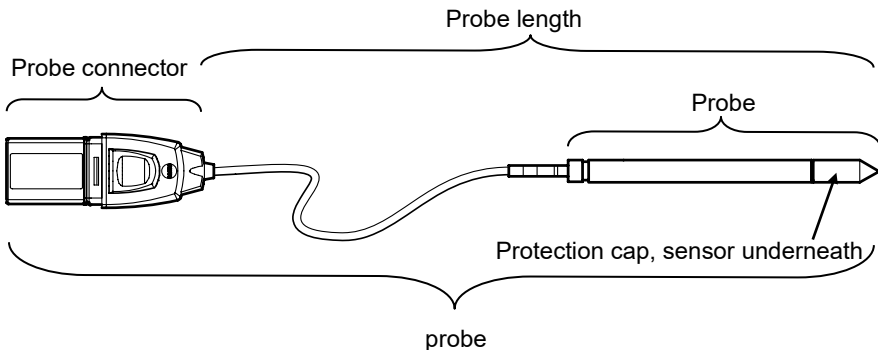

2.1.3 Accessories

The following accessories are available for probes in the testo 6600 range:

- Filters and protection caps (see *chapter 2.2.1.4*)
- Calibration certificate in accordance with ISO and DAkkS (see *chapter 4.2*).

2.2 Product description

2.2.1 Overview of probe and filter types

2.2.1.1 Probe version



A detailed description of the probe versions can be found from *chapter 2.2.2, testo 6601 wall probe*.

The following probe versions are available for the testo 6651 humidity transmitter:

probe	Article no.	Characteristic
testo 6601	0555 6600-L01	Wall probe version; accuracy to $\pm 1,7$ % RH; temperature range -20 °C to +70 °C/-4 to +158 °F
testo 6602	0555 6600-L02	Duct probe version; accuracy to ± 1.7 % RH; temperature range -20 °C to +70 °C/-4 to +158 °F
testo 6603	0555 6600-L03	Duct probe version; accuracy to $\pm 1,7$ % RH; temperature range -30 °C to +120°C/-22 to +248 °F
testo 6604	0555 6600-L04	Cable probe version; accuracy to ± 1.7 % RH; temperature range -20 °C to +70 °C/-4 to +158 °F
testo 6605	0555 6600-L05	Cable probe version; accuracy to ± 1.7 % RH; temperature range -30 °C to +120°C/-22 to +248 °F

2.2.1.2 Determining the accuracy/measuring uncertainty

The entries for the measuring uncertainty for the probe are determined in accordance with GUM (Guide to the Expression of Uncertainty in Measurement/DIN V ENV 13005). All parts that make up the measuring uncertainty given by Testo are listed below. When comparing the measuring uncertainty/accuracy between manufacturers, which components are included is to be taken into account. In many cases, not all elements that contribute to measuring uncertainty are assessed, for example if the error contribution of the production adjustment is shown separately or not at all.

The measuring uncertainty of the probe includes the sensor and its electronics as well as the output of the digital measuring signal:

1. **Linearity including scatter** Systematic error and scattering of the components (due to manufacturing tolerances)

2. **Hysteresis** Hysteresis indicates the maximum deviation of the readings that are obtained when you set the same value for the parameter, once coming from a smaller value, once coming from a larger value (humidity sensors actually have no hysteresis, but rather very slow adjustment effects that appear to be hysteresis when considered only for a short period.)

3. **Reproducibility** Repeatability (scattering of the readings in the event of the same parameter being entered successively)

4. **Production adjustment area** The measuring uncertainty of the adjustment area (including the reference instrument) in production

5. **Uncertainty of the testing** Uncertainty of the procedure for determining points 1 and 2.

2.2.1.3 Ordering options for testo 6600 probes (0555 6600)

Order code	Characteristic
Lxx Probe type	
L 01	Probe 6601
L 02	Probe 6602
L 03	Probe 6603
L 04	Probe 6604
L 05	Probe 6605
Mxx Protective filter	
M 01	Stainless steel sintered filter
M 02	Metal wire protection cap
M 03	Sintered PTFE filter
M 04	Open metal protection cap
M 05	ABS plastic cap (open)
Nxx Cable length	
N 00	Without cable (testo 6601)
N 01	1 m cable length (testo 6604, 6605)
N 02	2 m cable length (testo 6604, 6605)
N 05	5 m cable length (testo 6605)
N 23	Cable length specifically for duct versions (testo 6602, 6603)
Pxx Probe length	
P 07	Probe length approx. 70 mm (testo 6601)
P 14	Probe length approx. 140 mm (testo 6604)
P 20	Probe length approx. 200 mm (testo 6601, 6605)
P 28	Probe length approx. 280 mm (testo 6602, 6603, 6604)
P 50	Probe length approx. 500 mm (testo 6605)

2.2.1.4 Filters

One of the following filters or protection caps can be used for each probe version:

Filter*	Article no.**	Characteristic	Length A (mm)
M 01	0554 0647	Stainless steel sintered filter	33
M 02	0554 0757	Metal wire protection cap	40,3
M 03	0554 0759	Sintered PTFE filter	35
M 04	0554 0755	Open metal protection cap	35
M 05	0192 0265	Open ABS plastic cap	25

* When ordering the probe, please use this filter code (see *chapter 2.2.1.3, Ordering options for testo 6600 probes (0555 6600)*).

** When purchasing a replacement (filters only), please use this order number.

2.2.2 testo 6601 wall probe

The wireless testo 6601 probe is inserted into the testo 6651 humidity transmitter that is mounted on the wall and ready-wired.

At a glance

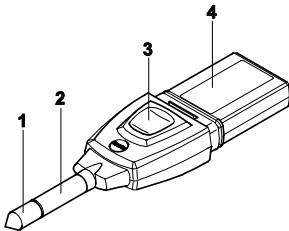

- 1 Filter (including: humidity and temperature sensor)
- 2 Probe shaft
- 3 Key
- 4 Connector



In the event of overpressures, the probe may become a projectile.

For assembly, see **Pressure resistance** on the following page.

Application

- Monitoring and regulating the production and storage air quality when manufacturing and storing hygroscopic products.

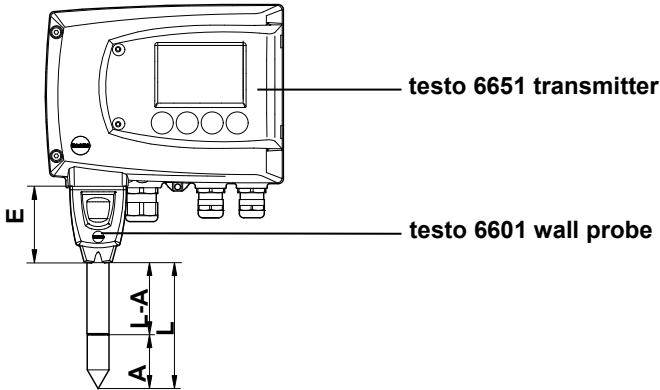

Technical Data

Parameters

- Humidity (% RH/°Ctd/°Ftd), etc.
- Temperature

Measuring range

- Humidity: 0 ... 100 % RH¹
- Temperature: - 20 ... 70 °C/-4 to +158 °F

Material

- Probe shaft: ABS plastic
- Connector: ABS plastic

Accuracy (at 25 °C/77°F)*

- Humidity
- Length 200 mm
- ±1.0 % RH / drift per year
- ± (1.7 % RH + 0.007 x reading) for 0 to 90 % RH
- ± (1.9 % RH + 0.007 x reading) for 90 to 100 % RH

- 0.02 % RH/K, dependent upon the process temperature (with a deviation of ± 25 °C/+77 °F)
- 0.02 % RH/K, dependent upon the electronics temperature (with a deviation of 25 °C/+77 °F)
- Temperature
- ±0.2 °C (±0.38 °F)
- Slope PT1000 class A
- * Refer to the charts below for the correlation between temperature and accuracy.
- Length 70 mm
- As with length of 200 mm, but with additional measuring error, specified for the operating mode 2 channels at 12 mA, without display light, relay off:

- Humidity: ±1.6 % RH (additional)
- Temperature: ±0.6 °C / ±1.1 °F (additional)

Reproducibility

- Better than ±0.2 % RH

Sensor

Response time without protective filter: t 90 max. 15 sec.

¹ For constant use in high humidity (> 80% rF at ≤ 30°C for > 12 h, > 60% rF at > 30°C for > 12 h), please contact us via www.testo.com/service-contact

Probe dimensions

- Diameter of probe shaft: 12 mm
- E = 55 mm
- L = approx. 70 mm or 200 mm
- L – A = 35 mm or 165 mm
- A (see Table Filters, *chapter 2.2.1.4*).

Pressure resistance

- 1 bar positive pressure (probe tip)
**
- * Refer to the charts below for the correlation between temperature and accuracy.
- ** If installing probe under pressure, please use cutting ring screw connection (order no. 0554 1795).

Measuring accuracy of testo 6601 wall probe

Humidity error according to amount $|\pm\% \text{RH}|$ as a factor of process humidity

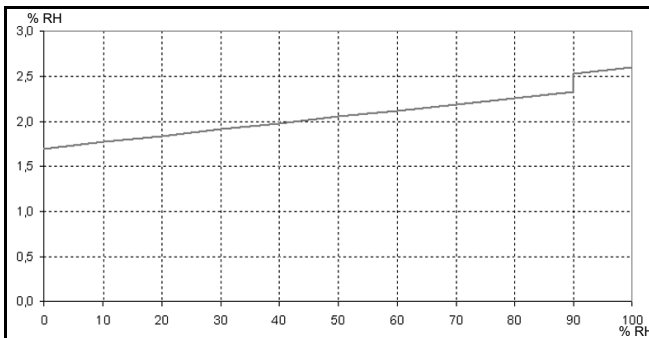

Temperature error as a factor of process temperature and temperature of electronics

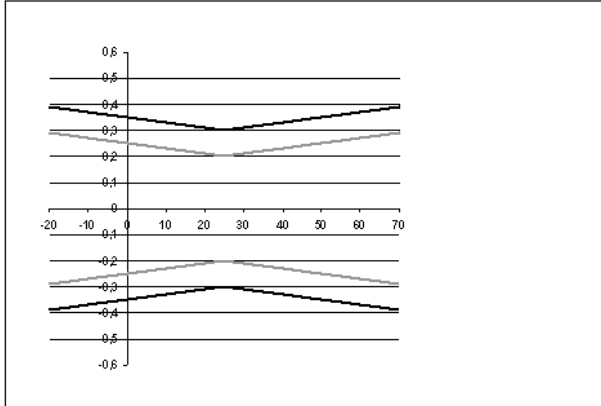

— System error 6681 + probe, electronics 25 °C/+77 °F
— System error 6681 + probe, electronics -25 °C to +70 °C/-13 to +158 °F

2.2.3 testo 6602/6603 duct probe

The testo 6602/6603 probe measures the humidity and temperature in air ducts.

At a glance

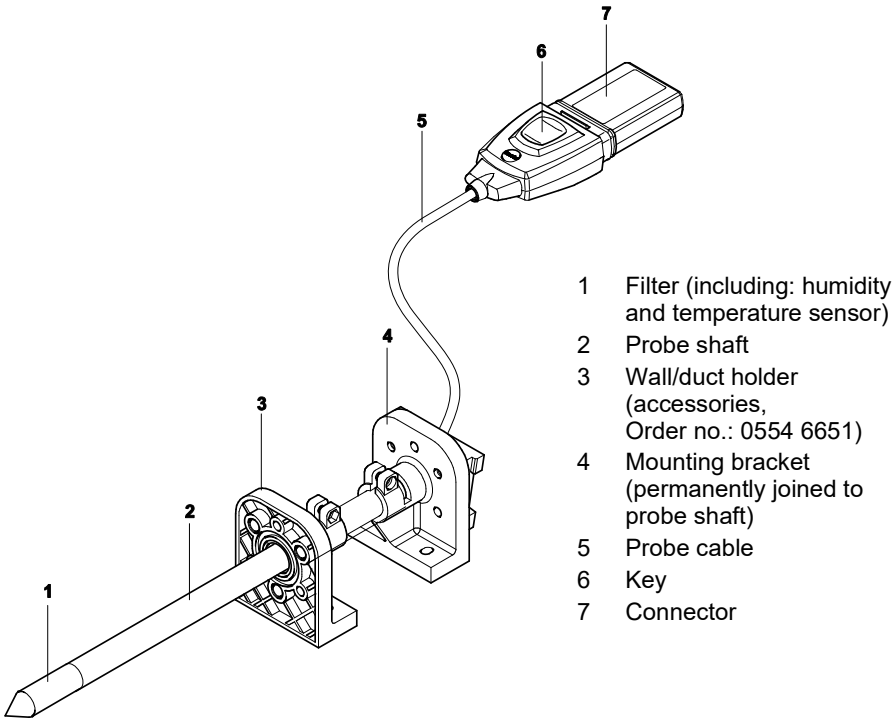

In the event of overpressures, the probe may become a projectile.

For assembly, see **Pressure resistance** on the following page.

Application

- Continuous measurement of humidity and temperature in air duct applications
- Monitoring and regulating the production and storage air quality in air ducts when manufacturing and storing hygroscopic products.

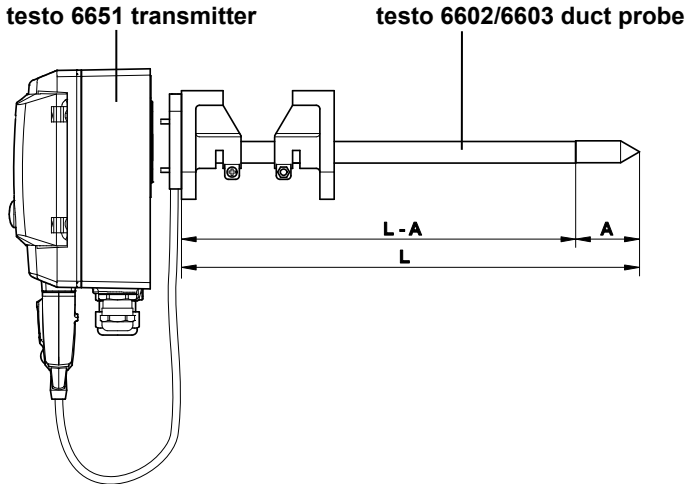

Technical Data

Parameters

- Humidity: (% RH/°Ctd/°Ftd), etc.
- Temperature

Measuring range

- Humidity: 0 ... 100 % RH²
- Temperature for
6602: -20 ... +70 °C/-4 to +158 °F -
6603: -30 ... +120 °C/-22 to +248 °F

Material

- Probe shaft: Plastic PA66GF30
- Line: Sheathed, FEP
- Connector: ABS plastic

Accuracy (at 25 °C/77 °F)*

- Humidity
 - ±1.0 % RH / drift per year
 - ± (1.7 % RH + 0.007 x reading) for 0 to 90 % RH
 - ± (1.9 % RH + 0.007 x reading) for 90 to 100 % RH
- 0.02 % RH/K, dependent upon the process temperature (with a deviation of 25 °C/+77 °F)
- 0.02 % RH/K, dependent upon the electronics temperature (with a deviation of 25 °C/+77 °F)
- Temperature
 - ±0.2 °C (±0.38 °F)
 - Slope PT1000 class A

Reproducibility

- Better than ±0.2 % RH

Sensor

² For constant use in high humidity (> 80% rF at ≤ 30°C for > 12 h, > 60% rF at > 30°C for > 12 h), please contact us via www.testo.com/service-contact

Response time without protective filter: t 90 max. 15 sec.

Probe dimensions

- Diameter of probe shaft: 12 mm
- L = 280 mm
- L – A = 245 mm
- A (see Table *Filters*, chapter 2.2.1.4).

Cable length incl. probe shaft and filter

- Customized for duct version

Pressure resistance

- 1 bar positive pressure (probe tip)

**

- * Refer to the charts below for the correlation between temperature and accuracy.

** If installing probe under pressure, please use cutting ring screw connection (order no. 0554 1796).

Measuring accuracy of testo 6602/6603 duct probe

Humidity error according to amount $|\pm\% \text{ RH}|$ as a factor of process humidity

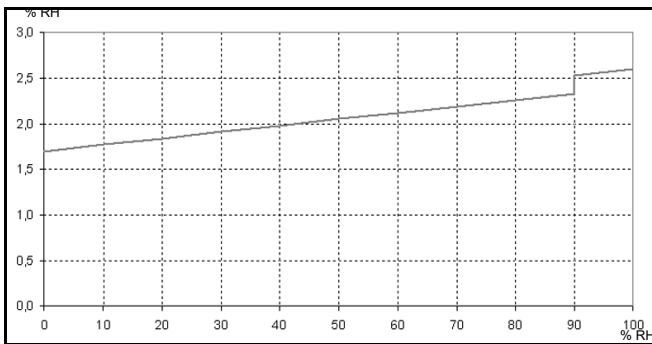

Temperature error as a factor of process temperature and temperature of electronics

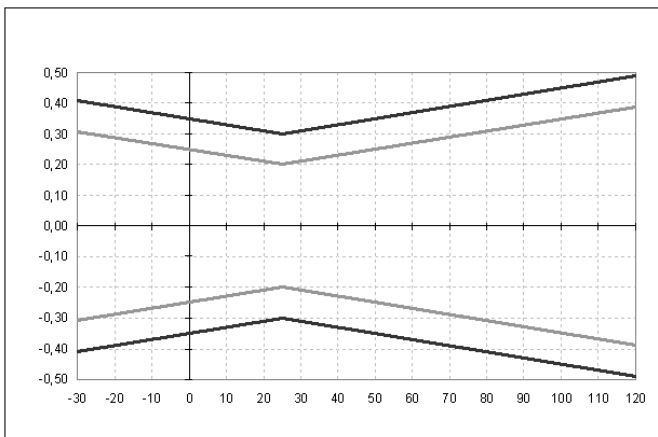

— System error 6681 + probe, electronics 25 °C/+77 °F
 — System error 6681 + probe, electronics -25 °C to +70 °C/-13 to

2.2.4 testo 6604/6605 cable probe

The testo 6604/6605 probes are used when the spatial separation of the transmitter and probe is required.

At a glance

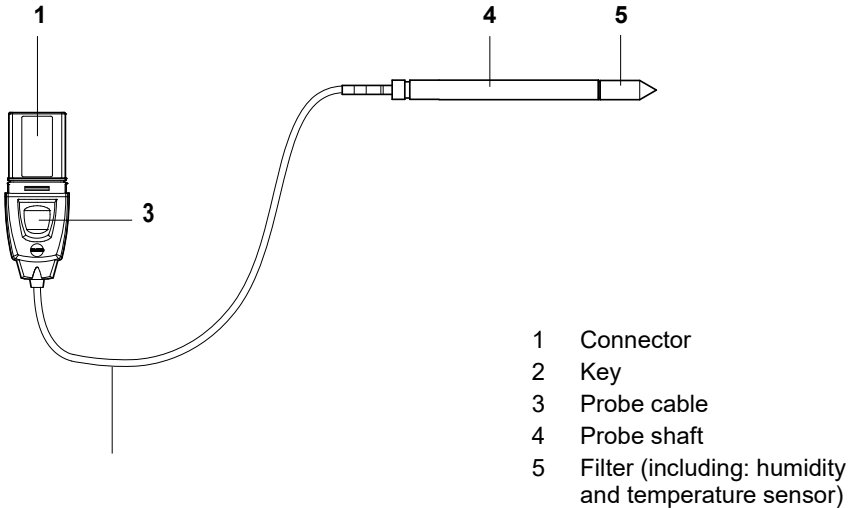

In the event of overpressures, the probe may become a projectile.

For assembly, see **Pressure resistance** on the following page.

Application

- Monitoring and regulating industrial humidity processes (apart from high-humidity processes), e.g. food production
- Monitoring the production and storage air quality when manufacturing and storing hygroscopic products.

testo 6651 transmitter

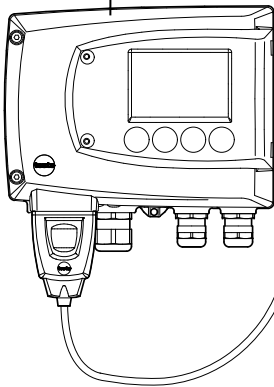

testo 6604/6605 cable probe

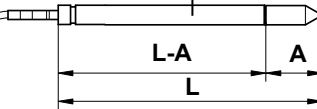

Technical Data

Parameters

- Humidity: (% RH/°Ctd/°Ftd)
- Temperature

Measuring range

- Humidity: 0 ... 100 % RH³
- Temperature for
6604: -20 ... +70 °C/-4 to +158 °F -
6605: - 30 ... +120 °C/-22 to +248
°F

Material

- Probe shaft for
6604: Plastic PA66GF30
6605: Stainless steel
- Line: Sheathed, FEP
- Connector: ABS plastic

Accuracy (at 25 °C/77 °F)*

- Humidity
- ±1.0 % RH / drift per year
- ± (1,7 % RH + 0.007 x reading) for
0 to 90 % RH
- ± (1.9 % RH + 0.007 x reading) for
90 to 100 % RH

- 0.02 % RH/K, dependent upon the
process temperature
(with a deviation of 25 °C/+77 °F)
- 0.02 % RH/K, dependent upon the
electronics temperature
(with a deviation of 25 °C/+77 °F)
- Temperature
- 6604: ±0.2 °C (±0.38 °F)
- 6605: ±0,15 °C / ±0,27 °F
- 6604: Slope PT1000 class A
- 6605: Slope PT1000 class AA

Reproducibility

- Better than ±0.2 % RH

Sensor

Response time without protective
filter: t 90 max. 15 sec.

Probe dimensions

- Diameter of probe shaft: 12 mm
- L = 6604 140/280 mm
L = 6605 200/500 mm
- L – A = 6604 105 mm/245 mm
- L – A = 6605 165 mm/465 mm
- A, see Table *Filters, chapter*
2.2.1.4.

³ For constant use in high humidity (> 80% rF at ≤ 30°C for > 12 h, > 60% rF at > 30°C for > 12 h), please contact us via www.testo.com/service-contact

Probe length incl. probe shaft and filter

- 1/2/5 m

Pressure resistance**

- testo 6604: 1 bar positive pressure (probe tip)
- testo 6605: PN 10 (probe tip)

* Refer to the charts below for the correlation between temperature and accuracy.

** testo 6604: If installing probe under pressure, please use PTFE ring screw connection (order no. 0554 1796).

testo 6605: If installing probe under pressure, please use cutting ring screw connection (order no. 0554 1795).

Measuring accuracy of testo 6604/6605 cable probe

Humidity error according to amount $|\pm\% \text{ RH}|$ as a factor of process humidity

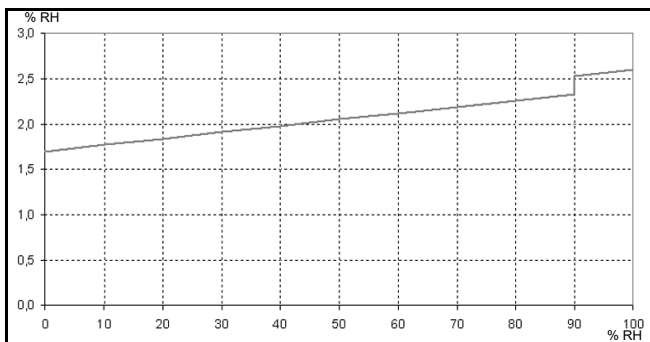

Temperature error as a factor of process temperature and temperature of electronics

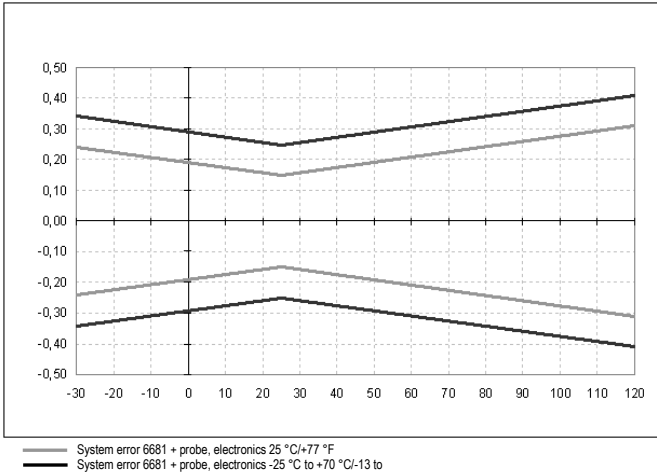

2.3 Commissioning

2.3.1 Installing the probe

2.3.1.1 Installing the testo 6601 wall probe

The testo 6601 probe (wall version) simply has to be inserted into the socket of the testo 6651 transmitter.

2.3.1.2 Install testo 6602/6603 duct probe

A description of the duct mounting of the testo 6602/6603 probe can be found in *volume 1, chapter 1.3.1.2, Duct mounting (for testo 6602/6603 probes)*.

2.3.1.3 Install testo 6604/6605 duct probe

- ✓ If used with these probes, the testo 6651 transmitter is mounted on the wall (see *volume 1, chapter 1.3.1.1*).
- Install probe according to the application and the measuring and spatial conditions.



In processes with which condensate forms at the humidity probe, install the probe vertically (filter points downwards).

A Wall mounting of probe

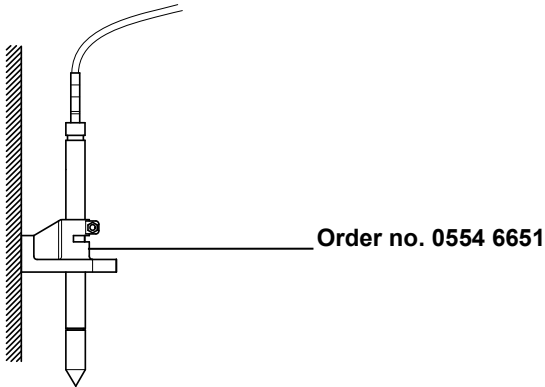

B Duct mounting of probe

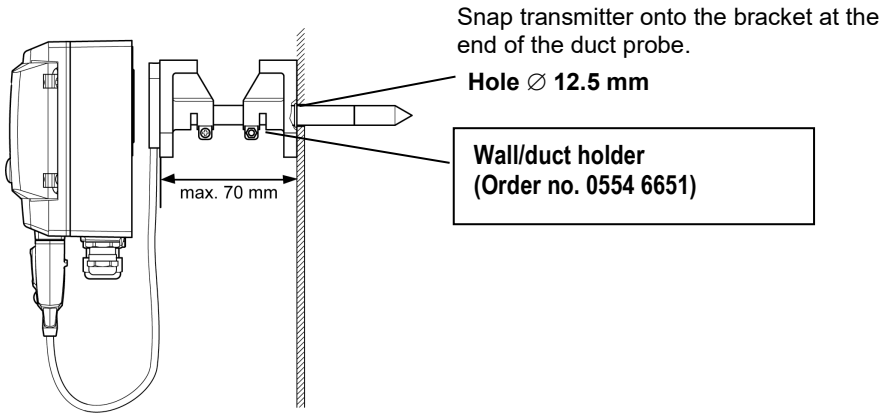

Atmospheric processes only. Alternatively, the single-hole duct holder (order no. 0554 1793) can also be used.

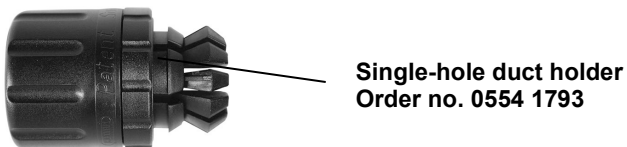

C Process mounting

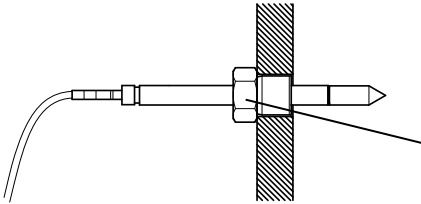

Cutting ring screw connection

Order no. 0554 1795 for testo 6605 probe

Order no. 0554 1796 for testo 6604 probe

- During installation, ensure that the probe cannot be damaged during operation.

2.3.2 Connecting/removing the probe to/from the transmitter

- Insert probe connector into socket of testo 6651 until it engages. The testo 6651 identifies which probe is connected.

To remove the probe, the lock release button on the probe must be pressed so that this can be removed

2.4 Maintenance and cleaning

2.4.1 Replacing filters/protection caps

2.4.1.1 Replacing the filter/protection cap for testo 6601 wall version

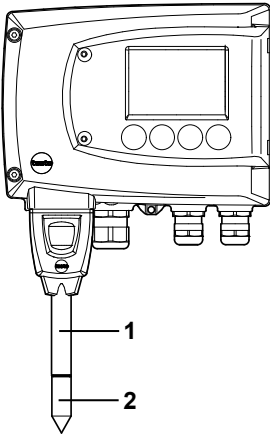

Do not damage the sensors when exchanging the filter/the protection cap and do not touch their surfaces!

- 1 Carefully unscrew defective filter/protection cap **(2)** from probe shaft **(1)**.
- 2 Carefully screw new filter/protection cap onto probe shaft.



Screw on protection cap by hand, i.e. do not tighten it using a tool.

2.4.1.2 Replacing the filter/protection cap for testo 6602/6603 duct version

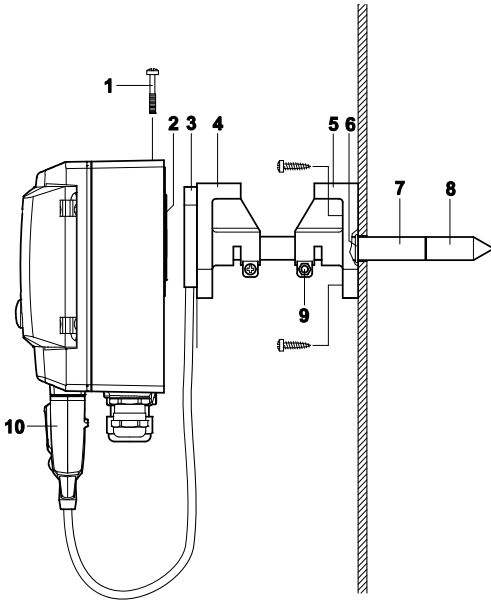

Do not damage the sensors when exchanging the filter/the protection cap and do not touch their surfaces!



Hint:

Mark the insertion length of the probe shaft near the screw (9).

- 1 Undo screw (9) and pull shaft probe (7) together with filter/protection cap (5) from the wall/duct holder (8).
- 2 Carefully unscrew defective filter/protection cap from probe shaft and carefully screw on new filter/protection cap.



Screw on protection cap by hand, i.e. do not tighten it using a tool.

- 3 Replace O-ring (6) if necessary. Push probe shaft into duct as far as the marking and fix position with screw (9).

2.4.1.3 Replacing the filter/protection cap for testo 6604/6605 cable version

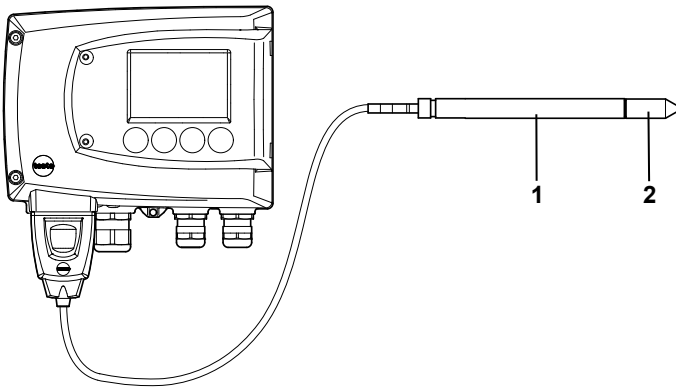

Do not damage the sensor when exchanging the filter/the protection cap and do not touch its surface!

- 4 Carefully unscrew defective filter/protection cap (2) from probe shaft (1).
- 5 Carefully screw new filter/protection cap onto probe shaft.



Screw on protection cap by hand, i.e. do not tighten it using a tool.

2.4.2 Cleaning the instrument and filter/protection cap

- Only clean the instrument carefully with a moist cloth.
- Do not use aggressive cleaning agents.
- Do not use any solvents.
- Unscrew cap or protection cap to clean, clean with compressed air and replace. Take care not to damage the sensor!

2.4.3 Replacing the sensors



It is not possible to replace the sensors with testo 6605.

As a result of the sensor concept, all sensors (except testo 6605) can be replaced as needed. In the process, all of the following steps must be adhered to.

- 1 Carefully unscrew filter/protection cap from probe shaft.
- 2 Remove defective sensor from slot with pincers.
- 3 Install new sensor in the slot.



During replacement, do not damage the sensor and do not touch its surface! Contamination and the smallest damages lead to incorrect measurement results.

- 4 Carefully screw filter/protection cap onto probe shaft.



Screw on protection cap by hand, i.e. do not tighten it using a tool.



To ensure the accuracy of the sensors,

- The humidity probe should then be adjusted using the control and adjustment set or in a humidity calibrator.

- The temperature should be adjusted using an appropriate reference.

The adjustment can also be performed by your Testo Service.

3 Parameterizing, adjusting and analyzing software (P2A software)

3.1 Specifications

The P2A software is used for the parameterizing, adjustment and analysis of testo transmitters. The following applies:

- Generally, all testo transmitters (as of 2007) are supported.
- For each newly purchased Testo transmitter, a free software upgrade must be installed, containing the instrument drivers for all transmitters which are connectable at that time.
- This upgrade can be downloaded free of charge at any time from the Testo homepage www.testo.com/download-center (requires registration).

The software must only be bought one time, even for owners of several testo transmitters.

3.1.1 Functions and use

In the P2A software, two different file types are used: The instrument and the parameter file.

Instrument file

The parameters of a particular transmitter are stored in its so-called instrument file. Using this file, the parameters can be edited and the instrument can be tested and adjusted.

Instrument files also contain the respective histories in addition to the parameter data, i.e. "log books" are kept for the previous parameterizations, adjustments and messages (see *chapter 3.3.5*).



Instrument files are ".cfm" format files.

Parameter file

Parameter files are not tied to a specific individual transmitter and contain only parameter data/no history data.

If you use various instruments of the same type, you can create parameter files once (e.g. by saving the appropriate instrument file as the parameter file) and transmit these onto the other instruments.



Parameter files are ".cfp" format files.

3.1.2 System requirements

Operating system

- Windows® 7
- Windows® 8
- Windows® 10

Computer

- The computer must fulfil the requirements of the respective operating system. The following requirements must additionally be fulfilled:
 - Interface USB 1.1 or higher
 - Graphic resolution min. 1024 x 768



Date and time settings are automatically taken over from the computer. The administrator must ensure that the system time is regularly synchronized with a reliable time source, in order to guarantee the authenticity of the data.

Software

The P2A software must be purchased and installed separately from the transmitter. If it is a new software version, the transmitter is already supported completely. Older P2A software versions can be updated via the P2A software upgrade.

3.1.3 Scope of delivery

Included in the scope of delivery are:

- P2A software
- USB driver



When working with the parameterizing, adjusting and analyzing software (P2A software), previous knowledge of Windows® operating systems is assumed.

3.2 First steps

3.2.1 Installing the software/driver



Administrator rights are required for installation.

3.2.1.1 Installing P2A software



Without the input of a licence key, the software will run only as a demo version (time limit 30 days).

- 1 You can download the software under the following link:

<https://www.testo.com/download-center>

If the installation program does not start automatically:

> Open download folder and start P2A.exe.

- 2 Follow the instructions of the installation wizard.
- 3 Click on [**Finish**] to complete the software installation.

Installing USB driver

- 1 You can download the USB driver under the following link:

<https://www.testo.com/download-center> (Testo USB driver)

If the installation program does not start automatically:

> Open download folder and start USBDriver.exe.

- 2 Follow the instructions of the installation wizard.
- 3 Click on [**Finish**] to complete the software installation.

3.2.1.2 P2A software upgrade

- 1 Download and store P2A software upgrade from **www.testo.com/download-center** (requires registration).
- 2 Select folder into which the downloaded Zip file was stored, and unzip the file.
- 3 Start file **P2A upgrade.exe**.
- 4 Follow instructions from installation assistant.

3.2.2 Starting the software

- > Click on **All Programs** (Windows® 7, Windows® 8, Windows® 10) | **Testo** | **P2A-Software**.



In Windows® 7 the window **User account control** is opened when starting the software the first time.

- > Click on **Accept**.
-

The program window is opened (see *chapter 3.3.1, User interface*).

3.2.2.1 Establishing a connection with the instrument

Multiple instruments can be attached, however only one connection is active at all times.

- ✓ USB driver is installed (see *chapter 3.2.1, Installing the software/driver*).
- 1 Start the P2A software.
 - 2 Connect adapter (supplied with the P2A software) to the service interface of the instrument (see *volume 1, chapter 1.2.4, Service interface*).
 - 3 Connect instrument/adapter to the PC via the USB interface.

The instrument file of the attached instrument is shown in the file list.

3.2.2.2 Activating the connection with the instrument

- Click on the desired instrument file.

The selected file is marked in colour and the connection with the instrument is activated.

If a connection with the instrument is established when the program is started, the corresponding instrument file is marked automatically.

3.3 Using the software

3.3.1 User interface

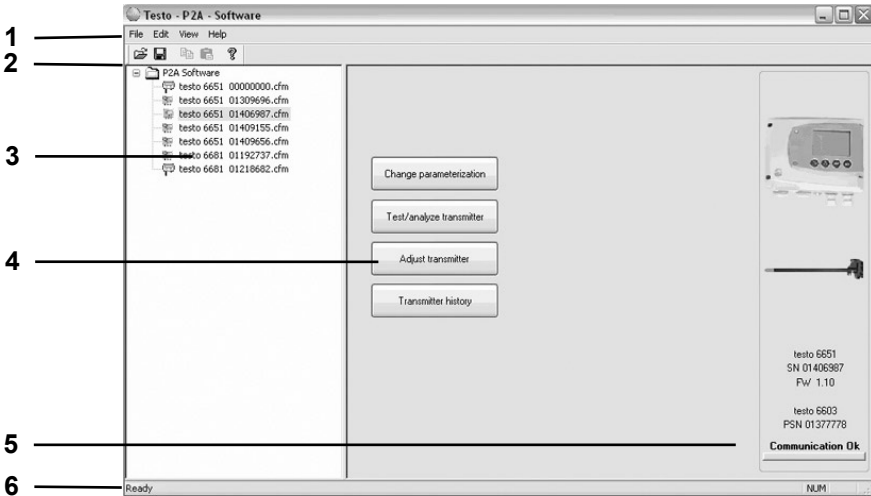

1 Menu bar:



Menu	Command	Explanation
File	Open	Shows the Windows dialogue for searching and opening files.
	Save as	Saves the parameters of an instrument or parameter file under a new name.
Edit	Copy	Copies the parameters of the marked instrument or parameter file in the cache.
	Paste	Pastes the parameters from the cache in the marked instrument or parameter file.
View	Toolbar	Activates/deactivates the toolbar or status bar.
	Status bar	
?	Check instrument connections	Checks the connections to a connected instrument without the instrument having to be activated.

Menu	Command	Explanation
	Service	A text file with the most important information on the computer and the software is opened via Display service data .
	About	Shows the version number of the P2A software.

2 Toolbar:

Shows the Windows-compliant icons for editing.

3 File list:

Icon	File	Explanation
	Instrument file	Instrument file Connection to the instrument has been established. <Type> <Serial number>.cfm File name should not be changed.
	Instrument file	Instrument file Connection to the instrument has not been established.
	Parameter file	<Type> <Serial number> <Date> <Time>.cfp File name can be changed. The name can be selected freely, but it is recommended that you retain the reference to the instrument. Parameter files are always marked red; the parameter values they contain are only forwarded to the instrument after being transmitted to the instrument file.

4 Function buttons:

[Change parameterization] see chapter 3.3.2

[Test/analyze transmitter] see chapter 3.3.3

[Adjust transmitter] see chapter 3.3.4

[Transmitter history] see chapter 3.3.5

Dialogues on editing and testing the instrument are opened by means of the buttons.

5 File information:

Status	Shown in the window
Instrument file is selected	Type, serial number, firmware version of the instrument or probe.
Parameter file is selected	Type, serial number and firmware version of instrument for which the parameter file was created.
Connection status	Green = connection is active, Red = connection is inactive.

6 Status bar:

Shows the current status when editing via the menu bar.

3.3.2 Editing instrument/parameter file

3.3.2.1 Changing instrument/parameter file

✓ The desired instrument/parameter file is marked.

1 Click on **[Change parameterization]**.

The **Properties of <Instrument type> <Serial number>** dialogue is opened with the **Change parameterization** register.

If the parameters were transmitted from other parameter files into the instrument file, a message is shown with which you can transmit the new parameters to the connected instrument using **[Yes]**.

If the parameters should not be transmitted, click on **[No]**.

2 Change or enter parameters in the corresponding fields.

Unit/analog output

Explanation

All analog outputs are parameterized in this mask.

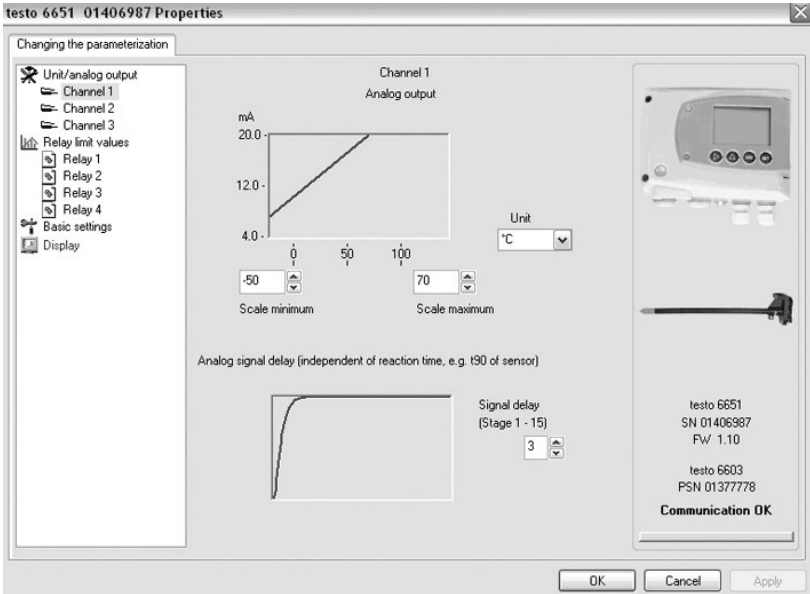

Unit/analog output (graphic)

Unit: 0 to 1 V/5 V/10 V or 4 to 20 mA.

Vertical: Current version of the analog output.

Horizontal: Min./max. scale end points of selected unit.

The curve changes in accordance with the entered value of scale minimum and maximum.

Scale minimum/maximum

The endpoints of the scaling can be selected up to the stored scale minimum and maximum. In the process, scaling can take place beyond the measuring range in order to adjust the analog output to the customer system.

Field	Explanation
Unit	<p>Selection of the physical unit.</p> <p>When changing the unit, standard values are set for scale minimum and maximum (see transmitter instruction manual for the scale final values).</p> <p>Caution!</p> <p>When changing the phys. unit, the relay limit values are set to the assigned default values.</p>
Signal delay (graphic)	<p>Curve changes according to the set signal delay.</p>
Signal delay	<p>Time interval in stages of 1 to 15: 1 = no delay 15 = longest delay.</p> <p>The signal delay is added to the reaction time of the sensor. The signal delay shows averaging over the time interval of the selected stage in seconds:</p> <p>Example</p> <p>Stage 10 = average of the readings from the last 10 seconds.</p>

Relay limit values 1 to 4

Explanation

In this mask, the relay is parameterized (if this transmitter option is available).



Only have the transmitter wired and connected by authorized personnel with the voltage disconnected.

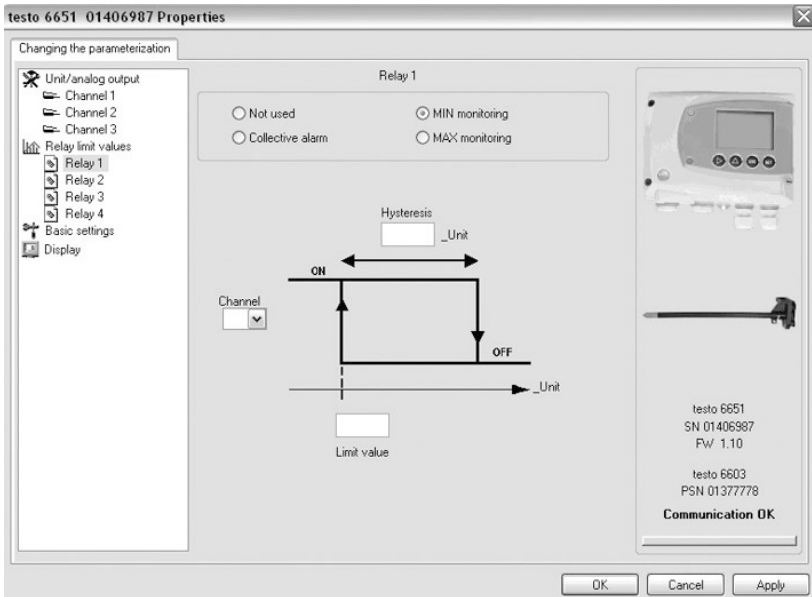

- Relay x Four relays are available (optional).

- Not used Relay is not used.
 Hysteresis image and input options are hidden.

- Collective alarm A relay can be used as a collective alarm detector in the event that selected messages appear. See below for selection of the messages.

- MIN monitoring Switched to ON below the limit value;
 switched to OFF when, following this, **Limit value** and **Hysteresis** are exceeded.

- MAX monitoring Switched to ON above the limit value;
 switched to OFF when, following this, **Limit value** and **Hysteresis** are undershot.

Field	Explanation
Hysteresis	To avoid switching cycles.
Channel	Selection of the channel that is to be monitored.
Limit value	Values for the limits of the unit selected in Unit/analog output ; 1 decimal place. When changing the phys. unit, the relay limit values are set to the default values.
Collective alarm	Explanation Selection of the messages (error, etc.) that should result in a collective alarm (or linkage).

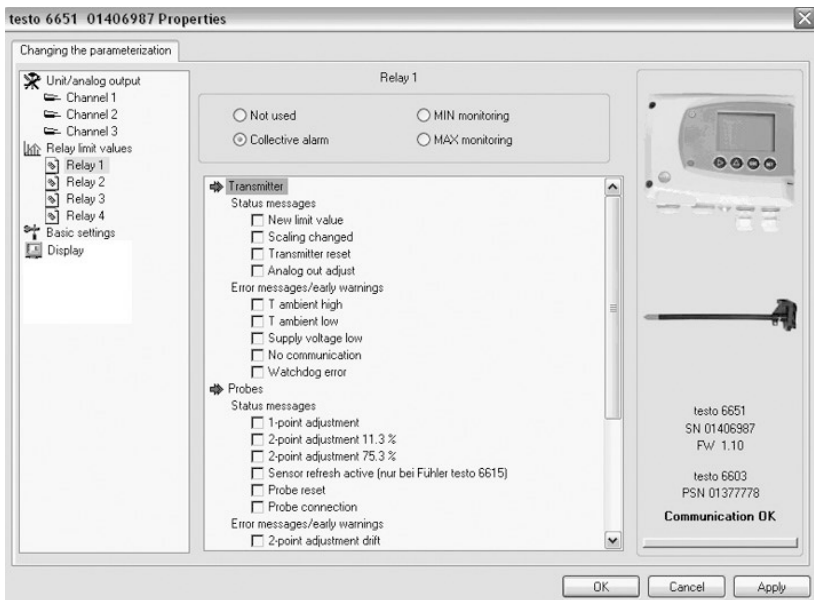

List field with checkboxes

Selection of which messages generated in the transmitter should be signalled as the collective alarm via the corresponding relay.

Basic settings

Explanation

Setting the absolute pressure

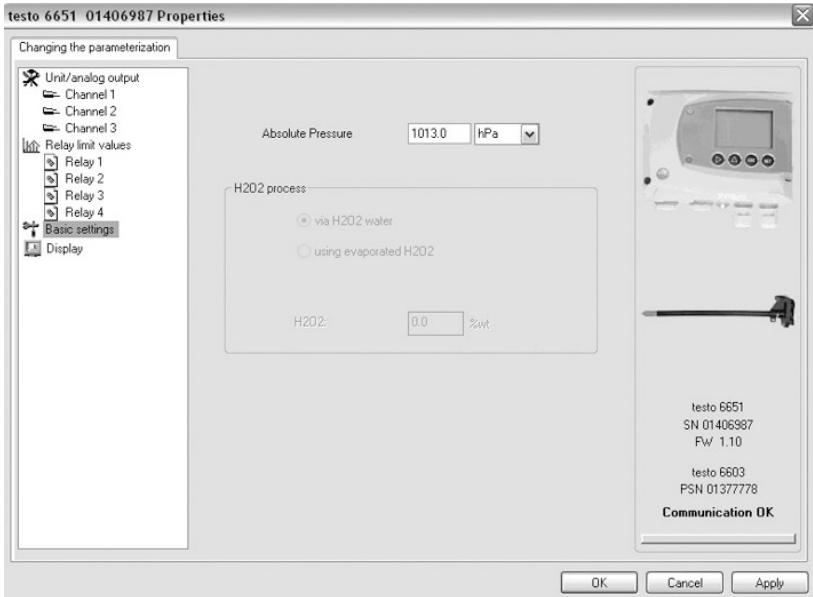

Absolute pressure

The absolute pressure is included in the calculation of the following units:

- °CtdA bzw. °FtdA

Display

Explanation

Setting the display functions (if a display is available on the transmitter).

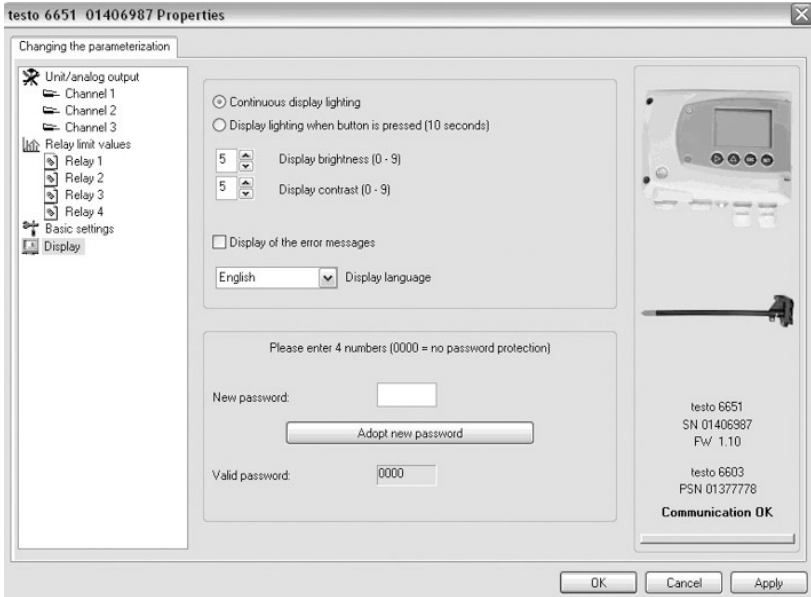

Continuous display lighting

Display lighting is permanently switched on.

Display lighting when button is pressed (10 seconds)

When a particular button on the instrument is pressed, the display lights up for 10 seconds.

Display brightness (0 to 9)

Setting the brightness between 0 and 9:
0 = dark
9 = light.

Display contrast (0 to 9)

Setting the contrast between 0 and 9:
0 = lower contrast
9 = higher contrast.

Field	Explanation
Display language	Selection of the language.
New password	The password consists of four numbers, each of which must be between 1 and 9. If the password protection is not to be used, the numerical code "0000" must be entered.
Adopt new password	Button for confirming the new password.
Valid password	Display of the current password.

3.3.2.2 Saving parameters

Parameters can be saved in new parameter files.

- 1 Mark instrument/parameter file
- 2 Click on **File > Save as** in the menu bar.
- 3 Select storage location and enter the file name.
- 4 Click on **[Save]**.

The new parameter file is shown in the file list.

Only the parameters are saved from an instrument file, the history data are not adopted.



The original name (Instrument type, Serial number) is suggested with the current date/time as standard, e.g. "testo 6681 01234578 061120 1403.cfp".

For a standard installation, the files are saved under "C:\Documents and Settings\All Users\Shared Documents\P2A Software". The path can differ depending on the version of the operating system.

3.3.2.3 Open parameter file

All parameter files stored in the standard directory path are automatically displayed in the file list when the software is started.

You can also open parameter files that are stored in other directories.

- 1 Click on **File > Open** in the menu bar.
- 2 Select the storage location and click on the requisite file.
- 3 Click on **[Open]**.

The selected file is opened. This can be changed and saved (see *chapter 3.3.2.2*).

3.3.2.4 Copying and pasting parameters

The parameters of a parameter file can be transmitted to an instrument file or another parameter file from the same instrument type.

- 1 Select file whose parameters are to be copied.
- 2 Click on **Edit > Copy** in the menu bar.
- 3 Select the file which is to be modified.
- 4 Click on **Edit > Paste** in the menu bar.

The parameters are transmitted to the file.



You can also use the common keyboard shortcuts for copying and pasting, i.e. CTRL C and CTRL V.

Parameters can also be transmitted using drag & drop, where you drag the icon of the parameter file onto the icon of the target instrument file.

3.3.2.5 Deleting instrument/parameter file

Instrument/parameter files can be deleted from the file list.

- 1 Click on the file that is to be deleted with the right mouse button.
- 2 Select the command **Delete** in the context menu.

The instrument or parameter file is deleted from the list.

3.3.3 Analyzing/testing the transmitter

In this section, you can test the outputs of the connected instrument, read off the limit values and reset the parameters to the factory settings.

The function is only available for instrument files.

3.3.3.1 Analyzing/testing the instrument

- ✓ The required instrument file is marked.

1 Click on **[Test/analyze transmitter]**.

The **Properties of <Instrument type> <Serial number>** dialogue is opened with the **Test/analyze transmitter** register.

2 Perform action:

Action	Explanation
Carry out factory reset:	Reset the unit, limit value and hysteresis parameters to factory settings (see <i>chapter 3.3.3.2</i>).
Test analog output:	Test channel 1/2.
Test switch outputs:	Manually switch relays 1 to 4 to test for proper function (see <i>chapter 3.3.3.3</i>).
Min./max. values display:	Overview of the minimum and maximum values measured since the last reset of the transmitter (see <i>chapter 3.3.3.5</i>).

3 Click on **[OK]** or **[Cancel]** to close the dialogue.

3.3.3.2 Carry out factory reset

- ✓ The required instrument file is marked.

1 Click on **[Test/analyze transmitter]**.

The **Properties of <Instrument type> <Serial number>** dialogue is opened with the **Test/analyze transmitter** register.

2 Mark **Transmitter test**.

Current operating hours are shown.

3 Confirm control query to perform the reset.

The values are reset to the default settings.

4 Click on **[OK]** or **[Cancel]** to close the dialogue.

3.3.3.3 Test analog output channel 1 / 2 / 3

✓ The desired instrument file is highlighted.

1 Click on **[Test/analyze transmitter]**.

The dialog **Properties of <Instrument type> <Serial number>** is opened with the tab **Test/analyze transmitter**.

2 Highlight channel and test value.

Field / button	Explanation
	Testing analog outputs (see <i>Volume 1, Chapter 1.4.6.5</i>).

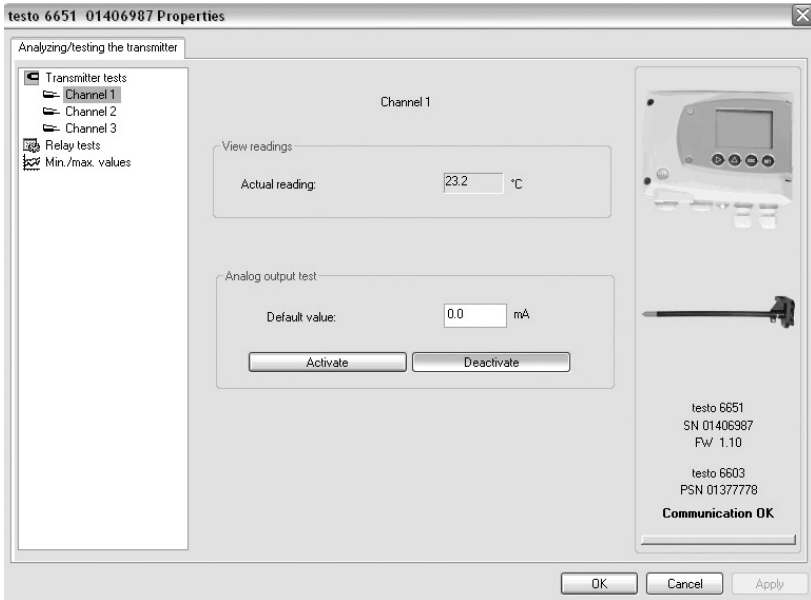

Current measurement value

Measurement value is refreshed every second

Unit

Unit according to the respective analog output type.

Pre-set value

Freely definable output value for the respective analog output type (V or mA), 1 decimal place.

Field / Button	Explanation
[Activate]	Clicking forwards the pre-set value entered to the respective analog output and to the test contacts. A warning indicates that if wired, the value will be transferred to the connected instruments . Now test the analog output using an accurate multimeter.
[Deactivate]	Ends connection of electrical parameter to analog output. The analog output returns to current measurement value .

- 3 To close the dialog, click on **[OK]** or **[Cancel]**.
The analog output returns to measurement mode.

3.3.3.4 Testing switch output relays 1 to 4

✓ The required instrument file is marked.

1 Click on [Test/analyze transmitter].

The **Properties of <Instrument type> <Serial number>** dialogue is opened with the **Test/analyze transmitter** register.

2 Mark **Relay tests** and test the values.

Field/button	Explanation
	Check the relay function (see <i>volume 1, chapter 1.4.6.6</i>).

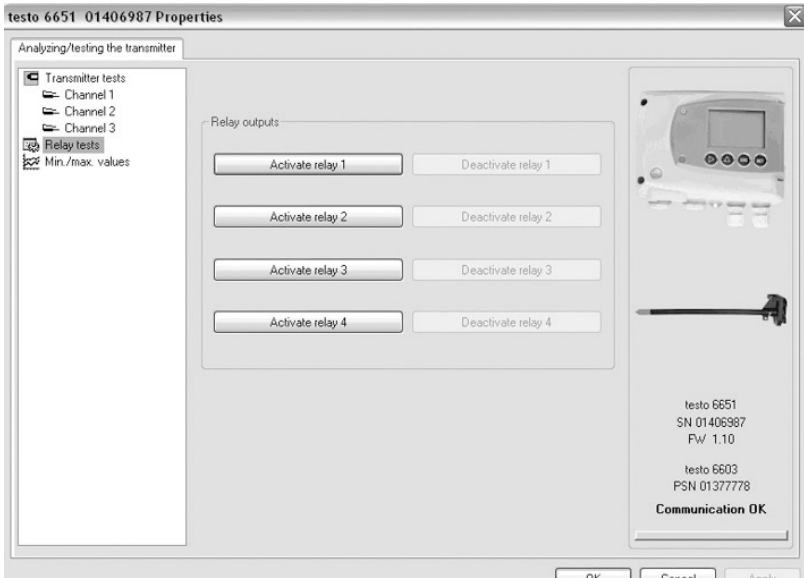

[Activate relay n] Close contact.
A warning informs that the value is being transmitted to a connected PLC, external display, etc. in the event of existing cabling.

[Deactivate relay n] Open contact.
A warning informs that the value is being transmitted to a connected PLC, external display, etc. in the event of existing cabling.

3 Click on [OK] or [Cancel] to close the dialogue.

The analog output returns to Measuring Mode again.

3.3.3.5 Displaying min./max. values

The transmitter saves the minimum or maximum value for each channel (measured since the last voltage supply or since the last manual reset).

✓ The required instrument file is marked.

1 Click on **[Test/analyze transmitter]**.

The **Properties of <Instrument type> <Serial number>** dialogue is opened with the **Test/analyze transmitter** register.

2 Mark **Min./max. values**.

Field/button	Explanation
	View the min./max. values of each channel.

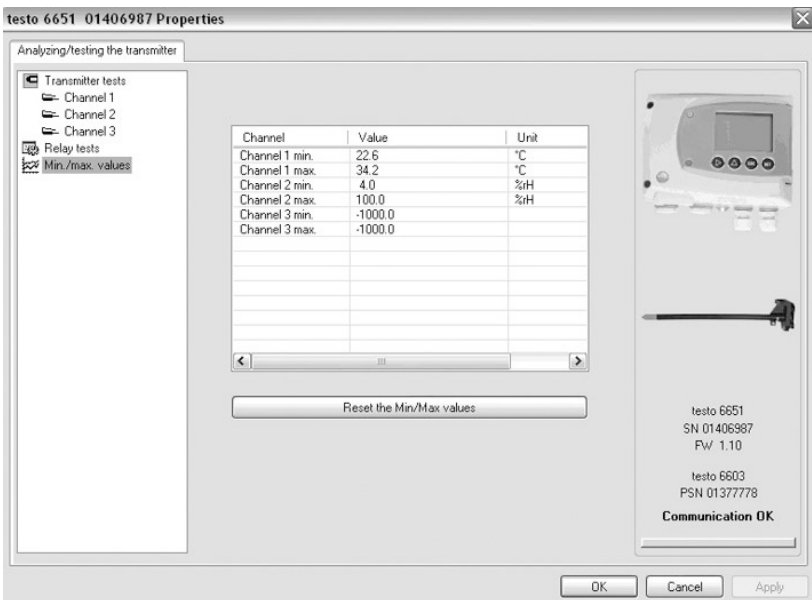

Channel	Min./max. of channel 1/2
Value	Min. or max. value, 1 decimal place.
Unit	Unit selected in Unit/analog output .

3 Reset **Min./max. values**.

- 4 Click on **[Reset the min./max. values]**.
- 5 Confirm control query to perform the reset.
The values are reset to the default settings.
- 5 Click on **[OK]** or **[Cancel]** to close the dialogue.

3.3.4 Adjusting the transmitter

This function is used to adjust an attached instrument. The following adjustments may be carried out using the software:

- 1-point adjustment (offset)
- 2-point adjustment (upper and lower adjustment point)
- Analog adjustment (entry via assistant/wizard).

Also see *volume 1, chapter 1.3.3, page 32, Adjusting the instrument for this.*

3.3.4.1 1-point adjustment

- 1 Expose the reference measuring instrument and the instrument to be adjusted to the same constant conditions and wait for equalization period to lapse.
- 2 Mark the instrument file of the connected instrument.
- 3 Click on **[Adjusting the transmitter]**.
The **Properties of <Instrument type> <Serial number>** dialogue is opened with the **Adjusting the transmitter** register.
- 4 Enter reference value and click on **[Carry out 1-point adjustment]**.
- 5 Confirm confirmation request.
The adjustment is carried out.

Field	Explanation
-------	-------------

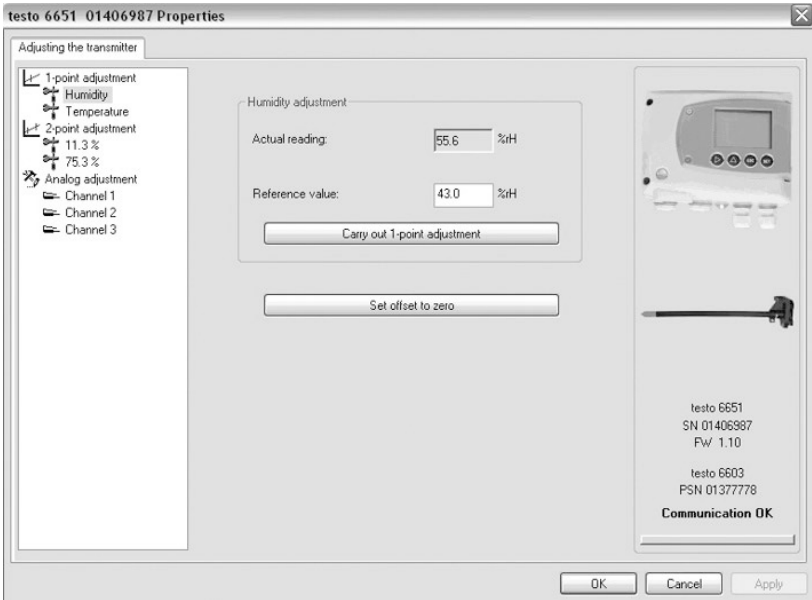

°C/°F	Selection of the unit; only for temperature adjustment.
-------	---

Current reading	Reading in °C/°F or % RH. Readings are updated every second.
-----------------	---

Reference value	Entry of the read-off value from the reference measuring instrument. Permissible entries: - max. 5 % RH deviation (sum of all 1-point adjustments) - max. 2 K (°C) deviation (sum of all 1-point adjustments)
-----------------	--

- Click on **[Set offset to zero]** to reset a transmitted reference value.

The current reading is used again.

- Click on **[OK]** or **[Cancel]** to close the dialogue.

3.3.4.2 2-point adjustment



Also see *volume 1, chapter 1.3.3.3, page 34.*

- 1 Expose the reference measuring instrument and the instrument to be adjusted to the same constant conditions and wait for equalization period to lapse.
- 2 Mark the instrument file of the connected instrument.
- 3 Click on **[Adjusting the transmitter]**.
The **Properties of <Instrument type> <Serial number>** dialogue is opened with the **Adjusting the transmitter** register.
- 4 Mark **11.3 %**, enter the reference value for the lower adjustment point and click on **[Lower adjustment point]**.
The adjustment is carried out.
- 5 Mark **75.3 %**, enter the reference value for the upper adjustment point and click on **[Upper adjustment point]**.
The adjustment is carried out.

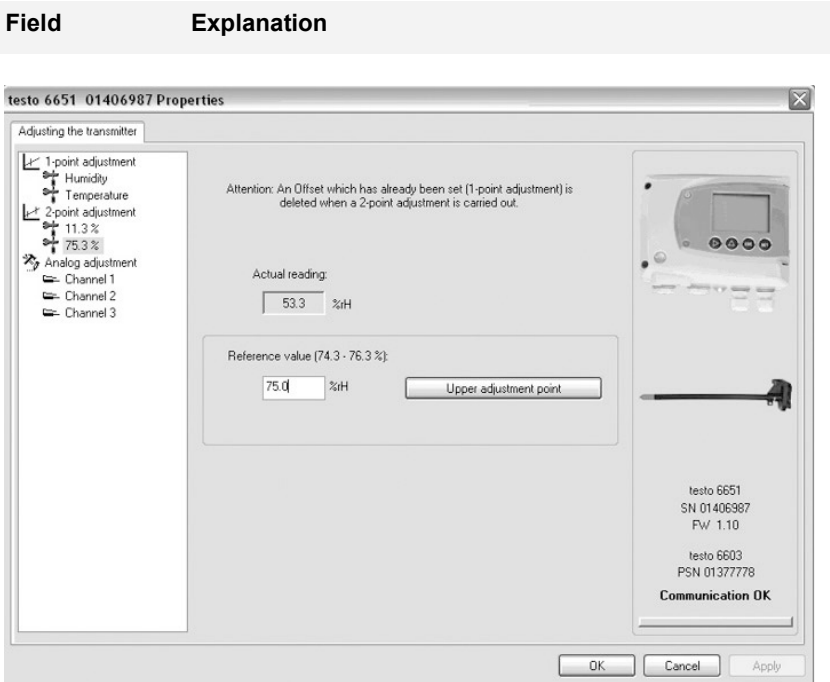

6 Click on **[OK]** or **[Cancel]** to close the dialogue.

3.3.4.3 Adjusting the analog output

- 1 Connect precision multimeter (see *volume 1, chapter 1.3.3.4*).
- 2 Mark the instrument file of the connected instrument.
- 3 Click on **[Adjusting the transmitter]**.

The **Properties of <Instrument type> <Serial number>** dialogue is opened with the **Adjusting the transmitter** register.

- 4 Click on **[Start wizard...]** and follow the instructions of the wizard.
The adjustment is performed when the wizard is closed.

Field	Explanation
-------	-------------

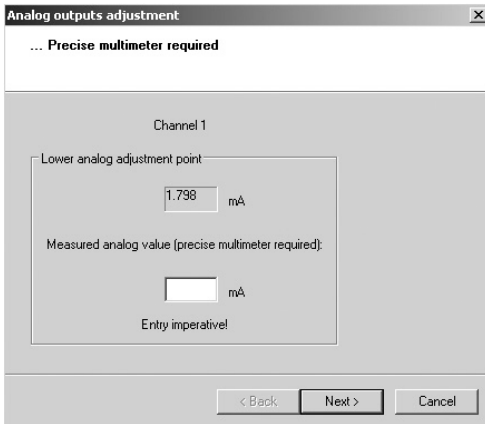

Default value The analog output value is given at the output:

- Lower adjustment point: 10% of the max. value
- Centre adjustment point: 50% of the max. value
- Upper adjustment point: 90 % of the max. value.

Measured analog value Required field:
Entry of the value read off at the multimeter.

3.3.5 Transmitter history

Parameterizations, adjustment processes and messages that have occurred are registered in the transmitter with an operating hours stamp.

In the history overviews (explained later in more detail), past processes and events can be made visible.



For parameter changes or adjustments that are performed directly at the instrument (via the user menu), "Transmitter" is entered in the **User** field and only the operating hour is entered in the **Date/time** field instead of operating hour/date/time.

For entries that are performed using the P2A software, the name of the user logged into Windows appears in the **User** field, while the operating hour is shown in the **Date/time** field.

- 1 Mark the instrument file of the connected instrument.
- 2 Click on **[Transmitter history]** button.
The "**Properties of <Instrument type> <Serial number>**" dialogue is opened with the **Transmitter history** register.
- 3 Click on the required entry in the list to change the display.

Parameterizati Explanation on history

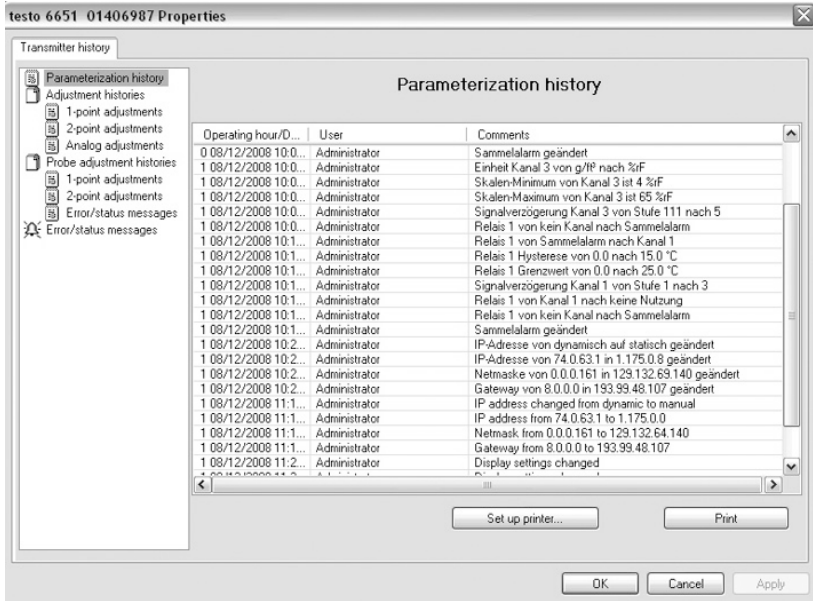

- Date/time** Format of the PC time is adopted from the settings of the operating system.
- User** Name with which the user is logged into the operating system.
"MUF" (= transmitter) if the change was performed at the instrument.
- Operating hours/date/time** Operating hour/time stamp at which the change at the instrument was performed.
- Comments** Type of parameter change, e.g. "Unit of channel 2 from °F to °C".

Adjustment histories **Explanation**

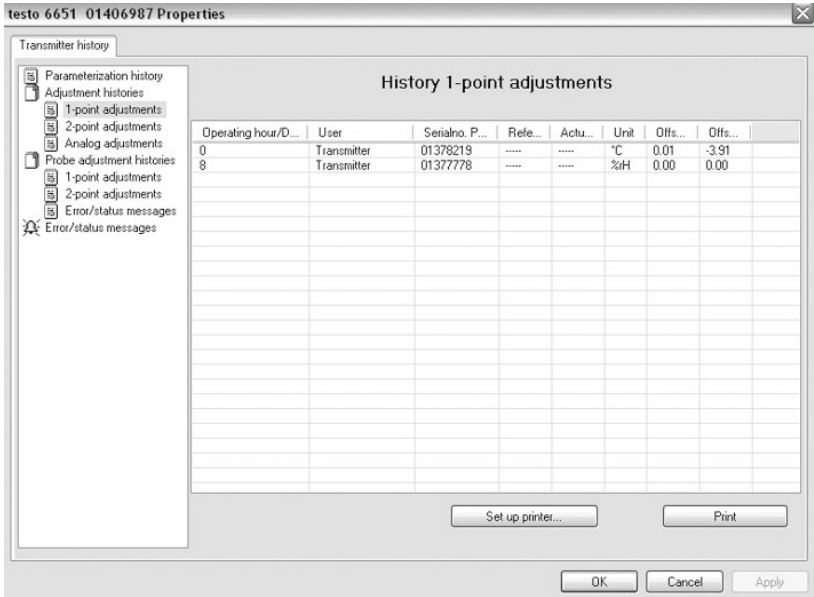

Selection: 1-point adjustments/2-point adjustments/Analog adjustments.

Date/time Format of the PC time is adopted from the settings of the operating system.

User Name with which the user is logged into the operating system.
 "MUF" (= transmitter) if the change was performed at the instrument.

Operating hours/date/time Operating hour/time stamp at which the change at the instrument was performed.

Serial no. probe Serial number of the probe.

Reference value If no changes were performed, no value is displayed.

Unit Unit during the adjustment.

Column	Explanation
Actual value before adjustment	1-point adjustment: If no changes were performed, no value is displayed.
Offset from	1-point adjustment: Value before the adjustment.
Offset to	1-point adjustment: Value after the adjustment.
Offset	2-point adjustment: Difference between target and actual value reported by instrument.
Channel	Analog adjustment: Channel 1 to n.
Specification	Analog adjustment: Actual value.
Reading	Analog adjustment: Reference value entered.
Offset	Analog adjustment: Deviation at time of adjustment.

Error/status messages **Explanation**

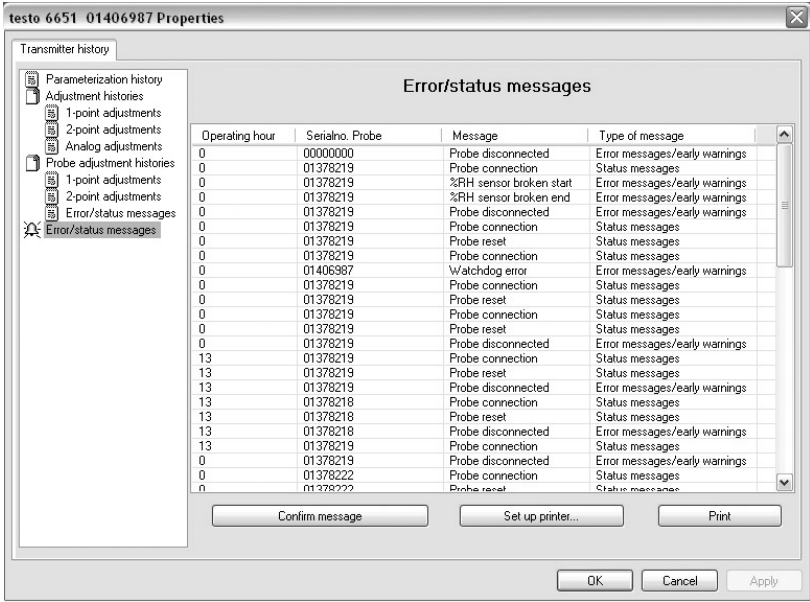

The table is shown only for error and status messages that were generated in the transmitter and have been saved.

Date/time Format of the PC time is adopted from the settings of the operating system.

Operating hours Operating hour at which the message appeared in the instrument.

User "MUF" (= transmitter) because the message was generated in the transmitter.

Message e.g. "Wrong probe". A non-compatible probe was connected.

Type of message e.g. early warning, status message.

- To print out the history data, click on **[Print]**.



The printing job is automatically sent to the default printer for the operating system.

The printout can be edited using **[Set up printer...]**.

This button is not working; the print command offers no selection of the printer.

- 4 Click on **[OK]** or **[Cancel]** to close the dialogue.

4 Tips and assistance

4.1 Questions and answers

Question	Possible causes/solutions
Connection to instrument cannot be established	Check connection cable/plug contacts
A message appears on the display	See <i>volume 1, chapter 1.5</i>
Malfunction (with or without display)	Analysis using the P2A software (see <i>chapter 3</i>).
Undo adjustment	A 1-point temperature/humidity adjustment can be reset to the current reading using [Set offset to zero] . The actual values before the adjustment can be read out from the corresponding history table. 2-point adjustments and analog adjustments can only be undone -by means of a factory reset.
When does a stable current reading appear?	After approx. 20 seconds

If we could not answer your question, please contact your dealer or Testo Customer Service. For contact data, see back of this document or web page www.testo.com/service-contact

4.2 Accessories and spare parts



An overview of the probes that can be used with the testo 6651 can be found in *volume 1, chapter 1.2.2*.

Designation	Article no.
Interface and software	
P2A software (parameterizing, adjusting, analyzing) incl. USB adapter	0554 6020
Fastenings, assembly aids	
Wall/duct bracket with M3 screw for fastening the transmitter to the probe and the probe to the wall/duct	0554 6651
Pressure-tight G 1/2" screw connection with cutting ring up to 16 bar	0554 1795
Pressure-tight G 1/2" screw connection with PTFE ring up to 6 bar	0554 1796
Plug-in connections	
Set of M12 plug-in connections (connector and socket) for power and signal lines	0554 6682
Sensor filters and protective caps	
PTFE protective cap	0554 9913
Stainless steel sintered filter	0554 0647
Wire mesh filter	0554 0757
Sintered PTFE filter	0554 0759
Protection cap made of metal (open)	0554 0755
Plastic protection cap (open)	0192 0265
Condensation protection	0554 0166
Adjustment equipment	
Salt pots (11.3/75.3 % RH adjustment set)	0554 0660
Ethernet	
Ethernet module for installation by customer	0554 6656
Ethernet plug	0554 6653

Designation	Article no.
Supply	
Mains unit (desktop, wall-mounted)	0554 1748
Mains unit (top-hat rail mounting)	0554 1749
Calibration	
Standard ISO calibration certificate, transmitter + probes	0520 0176
Special ISO calibration certificate, transmitter + probes	0520 0066
Standard DAkkS calibration certificate, transmitter + probes	0520 0276
Special DAkkS calibration certificate, transmitter + probes	0520 0236
DAkkS calibration certificate temperature, probes	0520 0261

4.2.1 Ordering options for testo 6651 transmitter (0555 6651)

Order code	Characteristic
Axx Version	
A01	0555 6651
Bxx Analog output	
B01	4 to 20 mA (2-wire, 24 VDC) (not with relay or Ethernet module) ⁴
B02	0 to 1 V (4-wire, 24 VAC/DC)
B03	0 to 5 V (4-wire, 24 VAC/DC)
B04	0 to 10 V (4-wire, 24 VAC/DC)
B05	0 to 20 mA (4-wire, 24 VAC/DC)
B06	4 to 20 mA (4-wire, 24 VAC/DC)
Cxx Display	
C00	without display
C02	with display/English
C03	with display/German
C04	with display/French
C05	with display/Spanish
C06	with display/Italian
C07	with display/Japanese
Dxx Cable entry	
D01	M16 PG screw connection (with relay, also M20)
D02	Cable entry NPT 1/2"
D03	Plug-in connections for power and signal lines
Exx Ethernet module	
E00	without Ethernet module
E01	with Ethernet module
Fxx Channel 1 Unit	
F01	% RH/Min/Max

⁴ In this option, the display illumination cannot be switched on

Order code	Characteristic
F02	°C/Min/Max
F03	°F/Min/Max
F04	°Ctd/Min/Max
F05	°Ftd/Min/Max
Gxx	
Channel 2 Unit	
G01	% RH/Min/Max
G02	°C/Min/Max
G03	°F/Min/Max
G04	°Ctd/Min/Max
G05	°Ftd/Min/Max
Hxx Relay	
H00	without relay
H01	4 relay outputs, limit value monitoring
H02	4 relay outputs, channel 1 limit values and collective alarm

4.2.2 Ordering options for testo 6600 probes (0555 6600)

Order code	Characteristic
Lxx Probe type	
L 01	Probe 6601
L 02	Probe 6602
L 03	Probe 6603
L 04	Probe 6604
L 05	Probe 6605
Mxx Protective filter	
M 01	Stainless steel sintered filter
M 02	Metal wire protection cap
M 03	Sintered PTFE filter
M 04	Open metal protection cap
M 05	ABS plastic cap (open)
Nxx Cable length	
N 00	Without cable (testo 6601)
N 01	1 m cable length (testo 6604, 6605)
N 02	2 m cable length (testo 6604, 6605)
N 05	5 m cable length (testo 6605)
N 23	Cable length specifically for duct versions (testo 6602, 6603)
Pxx Probe length	
P 07	Probe length approx. 70 mm (testo 6601)
P 14	Probe length approx. 140 mm (testo 6604)
P 20	Probe length approx. 200 mm (testo 6601, 6605)
P 28	Probe length approx. 280 mm (testo 6602, 6603, 6604)
P 50	Probe length approx. 500 mm (testo 6605)



Testo SE & Co. KGaA

Celsiusstr. 2

79822 Titisee-Neustadt

Germany

Tel.: +49 7653 681-0

E-Mail: info@testo.de

www.testo.com