

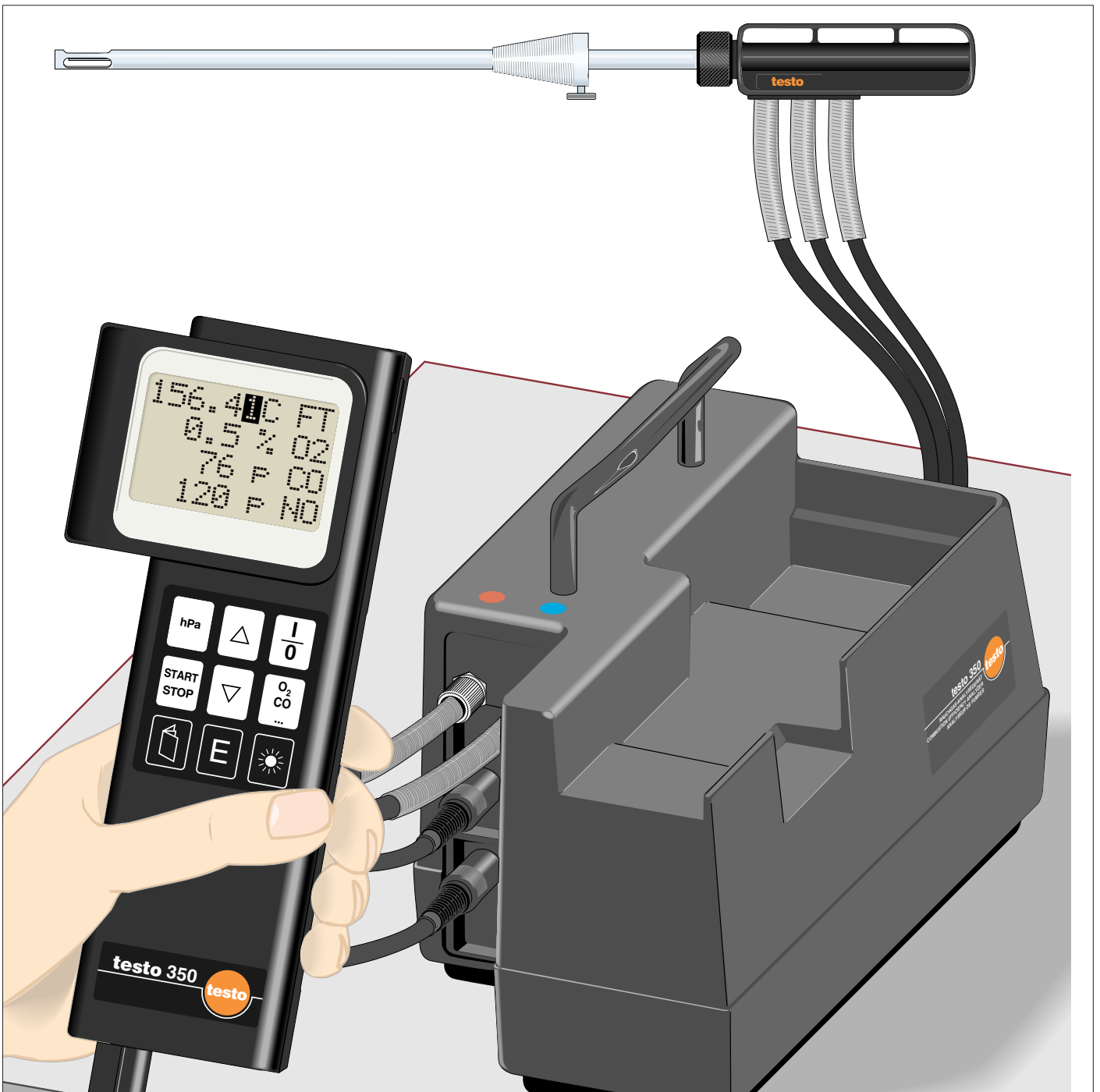

**testo 350**

Flue gas analyser

# Instruction Manual with Maintenance Manual





- 1 General**
- 1.1 System description of **testo 350** .....3
- 1.2 Warning .....4
- 1.3 Key assignment .....5
- 1.4 Connection of probes.....7
- 1.5 Condensate trap .....8
- 1.6 Power supply .....9
- 2 Flue Gas and Draught Measurement**
- 2.1 Flue gas measurement ..... 11
- 2.2 Draught measurement ..... 14
- 3 Operating with Gas Preparation **testo 339**** ..... 14
- 4 Temperature, Pressure, Velocity, Humidity Measurement**
- 4.1 Measurement menu.....16
- 4.2 Probe mode .....17
- 4.3 Temperature measurement .....18
- 4.4 Pressure/velocity measurement .....19
- 4.5 Humidity measurement.....20
- 5 Saving**
- 5.1 Calculating the memory capacity .....27
- 6 Additional functions menu**
- 6.1 Send .....28
- 6.2 Fuel .....30
- 6.3 Input  
O<sub>2</sub> reference value/CO<sub>2</sub> Max value; fuel-specific factors; heat carrier temperature; soot value, oil derivatives.....31
- 6.4 Service  
Instrument statuses; measuring variables .....32  
Switch-off limits .....33  
Indication order .....34  
NO<sub>2</sub> addition; O<sub>2</sub> calibration; recalibration for CO, NO, NO<sub>2</sub>, SO<sub>2</sub> .....35  
Print-Text; Time/Date; operating hours counter; memory mode .....38  
Pitot tube factor; analog outputs .....39
- 6.5 Error messages .....40
- 7 Upgrading modules**
- 7.1 Upgrading NO<sub>2</sub>, NO, SO<sub>2</sub> modules .....44
- 7.2 Upgrading the CO module .....45
- 7.3 Upgrading a second CO module .....45
- 7.4 Enabling the upgraded module.....45
- 8 Technical data**
- 8.1 Measuring instrument .....46
- 8.2 Probes .....47
- 8.3 Calculation information .....49
- 9 Warranty** .....51
- 10 Ordering data** .....52
- Short summary of the menus and additional functions** .....54

Maintenance manual

Measuring instrument conforms with  
EN 50 082 - 1,  
EN 55 011 Group 1 Class A

1.1 System description of **testo 350**

The **testo 350** flue gas analyser measures O<sub>2</sub>, CO<sub>2</sub>, CO and differential pressure accurately, quickly and reliably. It can measure NO, NO<sub>2</sub>, SO<sub>2</sub> if required, and it is also possible to measure humidity and velocity.

**testo 350** is particularly suitable for emission control and for adjusting larger industrial furnaces. Additional advantages include an overload protection for the CO measuring cells (an independent, freely definable switch-off level at high gas concentrations and simultaneous rinsing with fresh air) or the addition of measurement parameters via modules which can be fitted by the user.

The mobile gas preparation unit **testo 339**, can be connected as an option for long-term measurements. It dries the sample gas so that **testo 350** can measure accurately the NO<sub>x</sub> and SO<sub>2</sub> content over longer periods. **testo 350** has a large measuring range for process control in industrial furnaces and a high accuracy level, even in the lower measuring ranges, for limit value control.

Up to 500 measurements can be stored directly on location. The measured data is transmitted to a printer without the need of a cable, via an infrared transmission link. The RS 232 (V24) interface makes online data transmission to a PC possible.

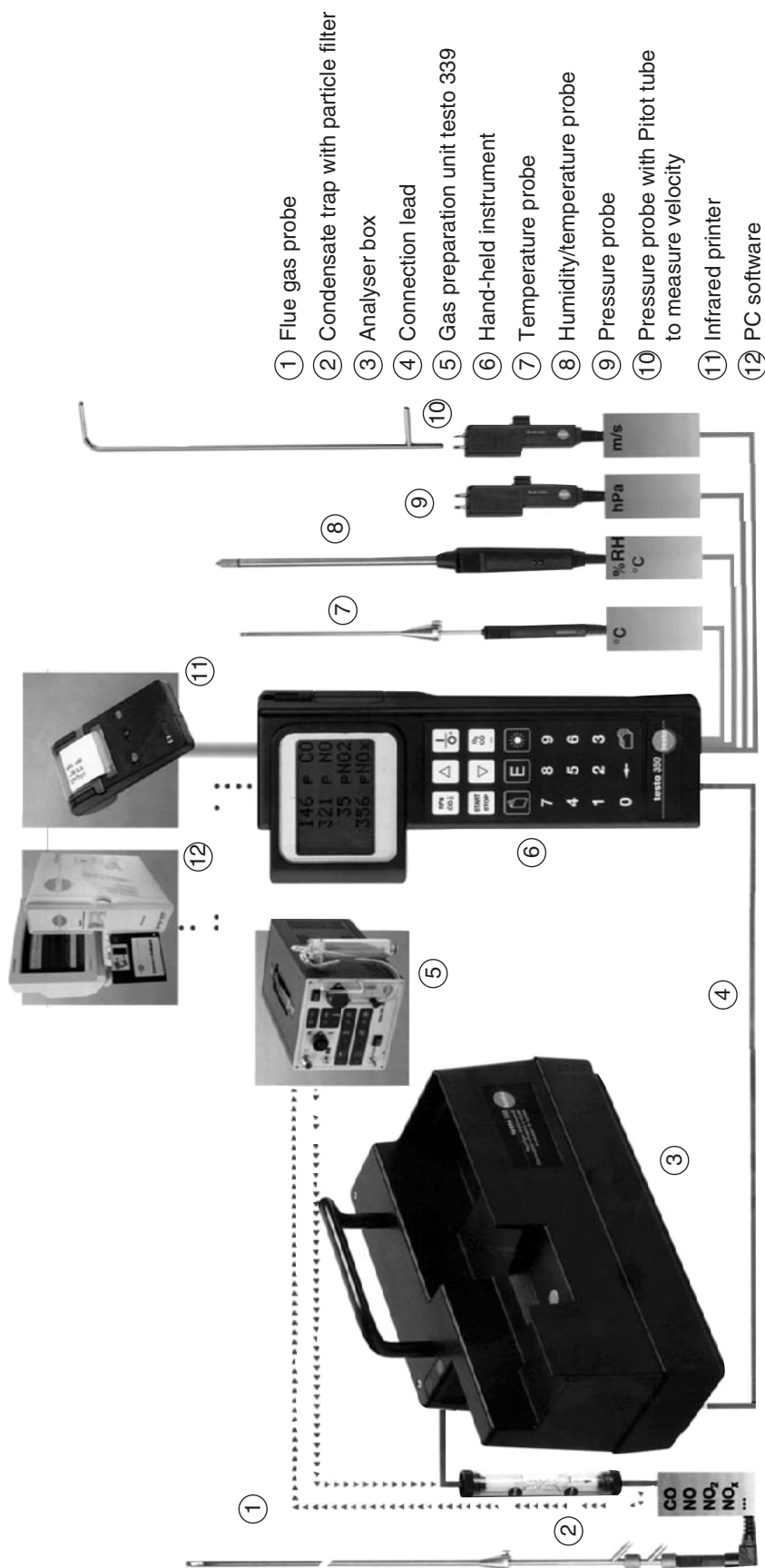

- ① Flue gas probe
- ② Condensate trap with particle filter
- ③ Analyser box
- ④ Connection lead
- ⑤ Gas preparation unit testo 339
- ⑥ Hand-held instrument
- ⑦ Temperature probe
- ⑧ Humidity/temperature probe
- ⑨ Pressure probe
- ⑩ Pressure probe with Pitot tube to measure velocity
- ⑪ Infrared printer
- ⑫ PC software



Please read carefully  
before use

## 1 General

### 1.2 Warning

For CO measurements of 40000 ppm or higher there must be sufficient ventilation otherwise there is a danger of poisoning.

Charge the built-in rechargeable battery fully before the first measurement or after a break of several days (see display of battery life during self-test or in the charging mode with the instrument switched off). Should the instrument not be used for long periods, recharge the rechargeable battery every 4 weeks to avoid a total discharge.

#### **Operation via mains unit**

Only use the original mains unit (part number 0554.0085 or 0554.0143) when operating the measuring unit.

#### **Flue gas probes**

Only flue gas probes with integrated condensate trap can be connected directly to the **testo 350**. Should a probe without integrated filter and condensate unit or without a gas preparation unit be connected, instrument failure will occur.

#### **Leak test**

Before a measurement is started, the complete measuring system (probe, condensate trap, tubes and connections) must be tested for leaks, for example, by attaching a compressed rubber ball. If there are leaks, the results of the measurement may be incorrect.

#### **Gas exit**

Ensure that the gas exit of the analyser is exposed during measurement, so that the gas can escape unhindered. The results of the measurement may otherwise be incorrect.

Particular care should be taken if the analyser box remains in the case during measurement and the case is not fitted with a gas outlet like the case from Testo.

#### **Condensate trap**

The condensate trap may only be emptied when the pump is switched off (otherwise the measuring cells are at risk).

#### **Measuring cells**

Small amounts of concentrated acids are contained in the measuring cells (except in the O<sub>2</sub> sensor □ electrolyte) and should therefore be treated as special waste.

#### **Temperature fluctuations**

If the ambient temperature fluctuates by more than  $\pm 10^{\circ}\text{C}$  the instrument should be switched off and switched on again (self-test) to achieve the correct measuring accuracy.

#### **Opening the housing**

The connection plug of the mains unit to the measuring box should be unplugged before opening the housing.

#### **Note**

The calibration of the O<sub>2</sub> cell in rooms with a low O<sub>2</sub> level (no fresh air) leads to error messages or incorrect measurement results.

#### **Note**

Keeping the measuring instruments in rooms where solvents are stored may cause damage to the measuring cells.

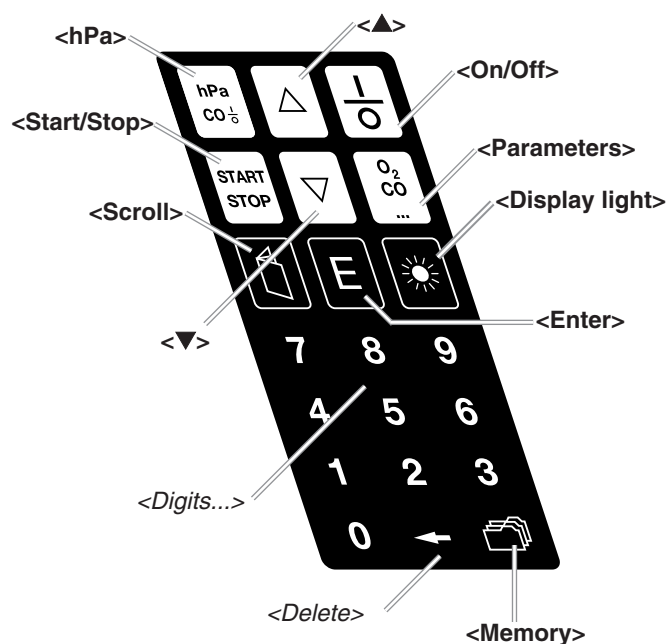

#### Use the following keys to:

- **Switch the measuring instrument on or off** <On/Off>
- **Select an item (a line) from a list** <▼>, <▲>
- **Confirm your selection /or activate a menu item** <Enter>
- **Save data** <Parameters>
- **Call up the “Additional functions” menu** <Scroll>
- **Cancel the processes or a selection** <Scroll>
- **Jump to the start of the measurement menu** <Parameters>
- **Measure the draught**
  - Set the zero point <hPa>
  - Freeze the measured value <hPa>
- **Work in the measurement menu to:**
  - Start the gas pump** for the measurement <Start/Stop>
  - Start the **CO measuring cell rinse manually** (when the pump is operating) and stop it again Both times <hPa>
  - Scroll through the measured values** of the various displays during measurement (page by page) <▼>, <▲>
  - Enter CO<sub>undiluted</sub> in the intermediate memory <Enter>
- **Switch on light** <Display light> (goes out automatically after 3 minutes)
- **Switch light to continuous operation** <Display light> + <On/Off> (first press <Display light>, keep pressed, then press <On/Off>)

#### You wish to:

- **Call up the memory menu** <Memory>
  - Save the measured values <Memory>
  - Delete the measured values from the memory <Delete>
  - Set the counter to zero <Delete>
  - Activate the menu “Send” from the memory management <Enter>

### Entering numbers

(The cursor is at the beginning of the first line at the first digit position of the number to be entered)

- Enter the numbers via the keyboard <1,2,3,4,...>
- Confirm the entry and jump to the next line <Enter>

*In the Comfort version the digits can also be entered in the same way as in the Basic version.*

*If the maximum number of characters has been entered the cursor jumps back to the first digit of the number so that corrections can be made.*

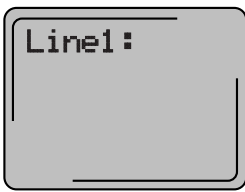

### • Entering text

- Select a letter from the alphabet <▲>
- Switch between upper case (A–Z) and lower case (a–z), special characters and numbers <hPa>
- Confirm the letters and jump to the next position <▼>
- Jump to the first position of the entry to make corrections <Enter>

If the maximum number of 10 characters (24 characters for print-text) has been entered you can jump back to the first position of the text so that corrections can be made.

- Confirm the text <Parameters>

Jump to line 2 in print-text

### Connecting the flue gas probe



Only flue gas probes with an independent, integrated condensate trap can be connected directly to the **testo 350** flue gas analyser (or via the gas preparation unit).

Insert the 8 pin plug of the flue gas probe into the appropriate socket (flue gas probe symbol). Observe the coloured markings when attaching the gas and draught hoses.

**Red: Gas path** (with condensate trap + filter)



Should the gas hoses be incorrectly connected, a complete instrument failure may occur which could damage the measuring cells.

**Blue: Draught path**

### Connecting a separate ambient temperature probe

When an air probe is connected to a hand-held instrument (connecting socket □ additional probes) the ambient temperature is continually measured by this probe.



Observe the maximum operating temperature indicated in the Technical/Ordering Data.

**Figure A**  
from the flue gas probe

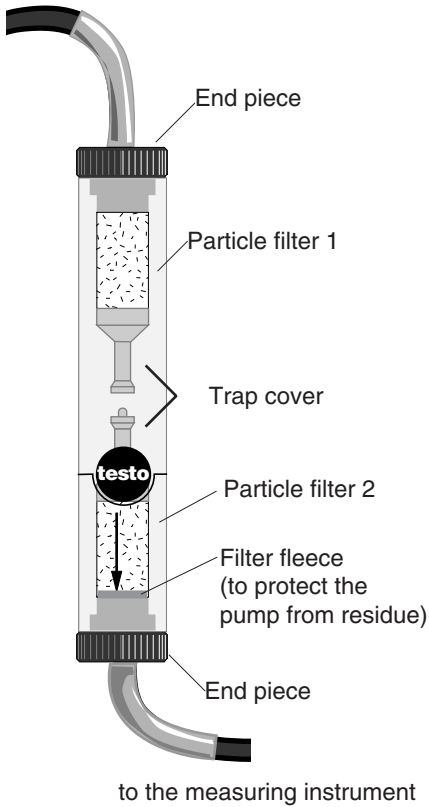

An independent condensate trap (Figure A) with 2 particle filters is fitted in the connecting lead of the 0600.8520/8720/9522 flue gas probes. Particle filters 1 and 2 are equipped with filter material.

The flue gas probes 0600.8521/8721/9523 are equipped with a second independent condensate trap (Figure B) as a prefractionator for the short-term measurement of NO<sub>2</sub> and SO<sub>2</sub>. In both condensate traps only particle filter 2 is equipped with filter material. Otherwise the NO<sub>2</sub> and SO<sub>2</sub> present in the flue gas would be removed by absorption. This would result in incorrect measuring results for NO<sub>2</sub> and SO<sub>2</sub>.

To remove the condensate, pull off one of the end pieces of the trap and pour out the condensate.

If you see that the filter material (fibrous web) is dirty, it must be replaced. Damp/wet filter material must be dried. Remove the filter tubes in order to replace/dry the filter material. Order replacement material for the filter with part number 0554.0084.

**Only empty the condensate trap when the pump is switched off.**



**The construction of the condensate trap requires a certain flow direction. It is marked by arrows on the housing. If the gas flows in the opposite direction, the condensate separation will not function correctly; this may lead to instrument failure.**

**When fitting and assembling the condensate trap, take care not to damage the seals or mix-up the trap covers.**

**Figure B**

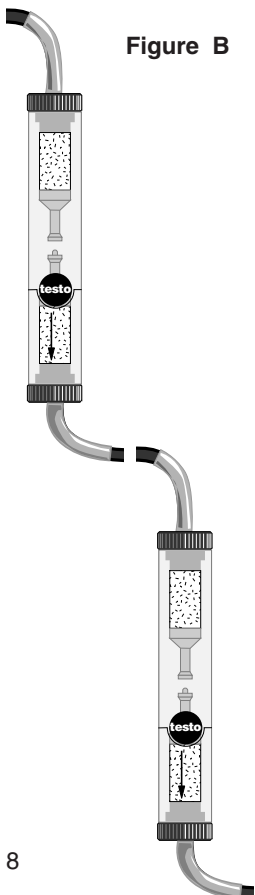

**Only particle filter 2 is to be equipped with filter material.**



**testo 350** can be operated via the built-in rechargeable battery via the 0554.0085 mains unit plugged into the analysis box. The hand-held instrument is supplied with power by the analyser box via the connection cable.

**For this reason the hand-held instrument and the analyser box must always remain connected.**

#### Rechargeable battery operation

In order to increase the life of the rechargeable battery, it is necessary for the instrument to be operated (once a month) without the mains unit until the rechargeable battery has been run down, then recharge the rechargeable batteries. The data saved in the hand-held instrument remain there with the leftover battery charge for at least 3 weeks after automatic switch-off.



Since the NO measuring cell (if fitted) is *permanently* supplied with a voltage via the rechargeable battery in the instrument, the battery must be regularly recharged via the mains unit.



Recharged...  
(compensation charging)



When switched off, 5 hours are needed to recharge the built-in rechargeable battery via the mains unit. It is possible to effect measurements while the battery is being recharged (buffer operation) but it means that recharging will take longer. Once rapid recharging is complete there is a switchover to compensation charge. You can see what stage compensation charging is at by the disappearance of the line "Charging" in the display and the display of 4 battery symbols. The measuring instrument can remain plugged into the mains unit without any danger to the rechargeable batteries.

If the mains unit is connected and the instrument is switched off the display shows that the internal rechargeable battery is being recharged.

The rechargeable battery voltage is shown (in the form of 4 segments) during the self-test. Information on the actual battery life cannot be given, as this depends on the condition of the rechargeable battery. With newly-recharged batteries, a battery life of 3.5 hours can be expected (with the pump operating continuously). This time can, however, be considerably reduced if the display light or CO rinsing pump is activated.

Please note:

The rechargeable battery should only be recharged at an instrument temperature of between 5 °C and 45 °C. The error message, opposite, is shown if the instrument temperature is outside this range and the battery is not recharged.

#### Mains operation

When connecting the mains unit to the analyser ensure that the connection plug is correctly positioned. A good connection is confirmed if the red LED in the mains unit lights up (and the message "Charging" is shown in the display of the hand-held instrument which is switched off).



It is normal for the mains unit to heat up. The instrument is protected from too high a temperature (eg due to an instrument error) by a heat protection switch.

If the instrument is switched off and the mains unit is still connected, the instrument goes immediately into the charging mode (message in display: "Charging" is shown after approximately one minute).

For the Comfort version hand-held instrument there is a battery chamber available for a 9V block battery. A 9V battery placed here stores the measured values in the memory, input data and the internal clock if the:

- connection between the hand-held instrument and the analyser box is interrupted
- rechargeable battery in the analyser box has run down.

This battery provides additional security and is not absolutely necessary. The power consumption of this battery is very low. It is therefore recommended that the condition of the battery is checked from time to time (eg for leaks). During the check the hand-held instrument must be connected to the analyser box in order to store the data saved and the date/time. The rechargeable battery or the mains unit then take over storage of the data.

### **Battery chamber in the Comfort hand-held instrument**

The battery chamber is located on the side of the measuring instrument. When inserting the battery push the chamber cover towards the rear of the instrument and place the battery in the chamber. **Ensure that the polarity is correct.** Replace the chamber cover.

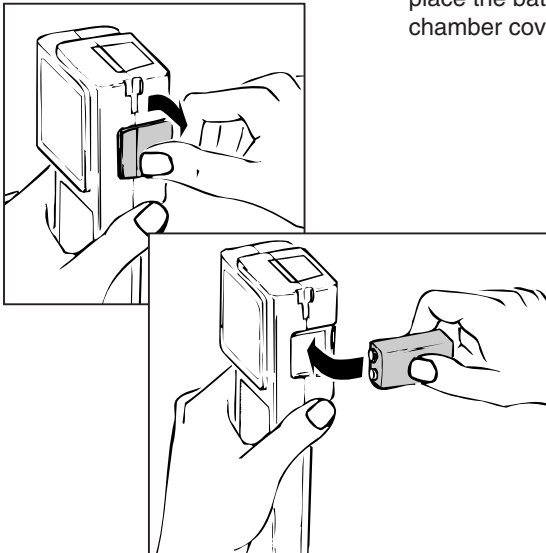

## 2 Flue Gas and Draught Measurement

### 2.1 Flue gas measurement (pC, O<sub>2</sub>, CO<sub>2</sub>, CO, NO<sub>x</sub>, SO<sub>2</sub>)



```
Self-test
18.8 °C AT
Accu:0000
Time=19
```

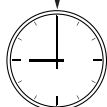

60 seconds  
End of self-test

```
O2 cell
calibrate
adjust
O2 19.5%
```

```
O2 cell
calibrate
adjust
O2 21.0%
```



```
Heat.OilEL
Nat. gas
Liquid gas
Wood/Coke
```



```
25.0 °C FT
21.0 % O2
98.5 Effg
36 P CO
```



Switch on the measuring instrument (the flue gas probe is placed in the fresh air).

The measuring instrument carries out a self-test (approximately 60 seconds) and rinses the measuring cells with fresh air. The rechargeable battery life is shown in the form of a maximum of 4 segments (for maximum charge). The remaining time of the self-test is shown in seconds in the bottom display line.

The temperature of the fresh air drawn in by the flue gas probe is displayed in the second line. If a separate room temperature probe is attached to the hand-held instrument the ambient temperature is displayed.

The self-test can be stopped after 10 seconds by pressing <Start/Stop> (time left <50 seconds). The instrument then goes straight to the probe mode (refer to Chapter 4.2).

The self-test usually lasts approximately 60 seconds.

The instrument may go into the self-test 3 or 4 times following measurements in high gas concentrations or due to a cell defect.

Once completed, **testo 350** indicates the end of the self-test. The value shown in the 4th line must be set at 21.0%.

The cursor is on the first digit. The value "21.0" is input as described in Chapter 1.3 (Key assignment), in the section Entering numbers.

The input value is activated by pressing <Parameters>, **testo 350** goes into the Service sub-menu "Fuel Selection".

Select the fuel required (<▼>/<▲>) and

jump to the **measurement menu** by pressing <Parameters> or <Enter>.



## 2 Flue Gas and Draught Measurement

### 2.1 Flue gas measurement (PC, O<sub>2</sub>, CO<sub>2</sub>, CO, NO<sub>x</sub>, SO<sub>2</sub>)

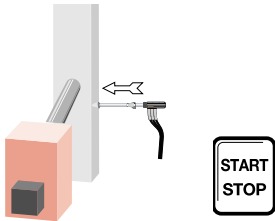

Place the flue gas probe to the flue gas and start the pump.

**When measuring make sure that the gas exit (bottom of the analyser) is free so that the gas can flow freely.**



**When using a service case an unobstructed gas flow must be guaranteed.**

**If this is not adhered to, it can lead to incorrect measuring results.**

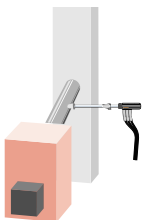

Position the flue gas probe in the centre of the flow (□ maximum flue gas temperature FT).

The measured values selected in the Additional functions menu and the Service sub-menu under "Indication order" are shown on 4 lines. Using the <▼> key you can call up other measured values in blocks of 4 parameters. By pressing <Parameters> you jump back to the first display window.

Gas pump operation is shown by an arrow running from the bottom to the top of the display in column eight. If the pump is not operating an arrow is not shown.

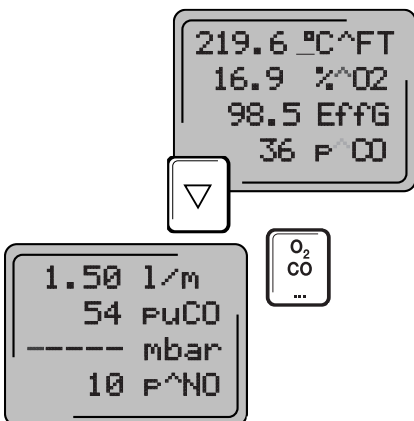

**The pump automatically switches off if the gas concentration is too high. (Refer to the Additional functions menu, Service sub-menu "Determining switch-off limits".**



If the measured values are not changing stop the pump. The measured values are "frozen" but not saved. If the pump is restarted these values are lost.

## 2 Flue Gas and Draught Measurement

### 2.1 Flue gas measurement (pC, O<sub>2</sub>, CO<sub>2</sub>, CO, NO<sub>x</sub>, SO<sub>2</sub>)

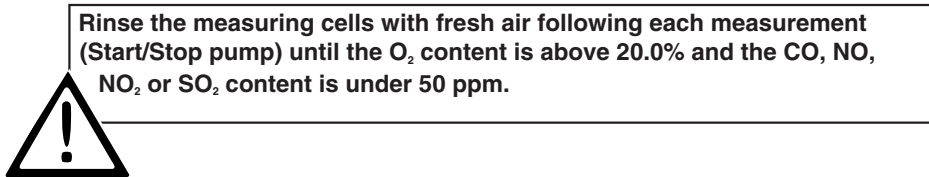
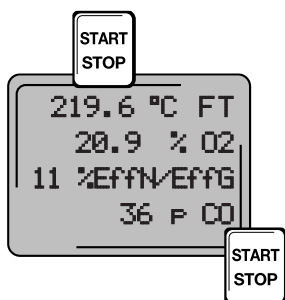
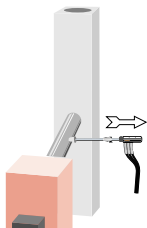

Rinse the measuring cells with fresh air following each measurement (Start/Stop pump) until the O<sub>2</sub> content is above 20.0% and the CO, NO, NO<sub>2</sub> or SO<sub>2</sub> content is under 50 ppm.

#### Operation with two integrated CO cells

The following CO cell types can be integrated in **testo 350**:

- CO type 1: 0 to 10 000 ppm CO, H<sub>2</sub> compensated; display: "CO"
- CO type 2: 0 to 20 000 ppm CO, display: "Co"
- CO type 3: 0 to 40 000 ppm CO; display: "co"

The following combinations are possible when two CO cells are built in:

- Combination 1: CO type 1 and CO type 3**  
CO type 1 must be mounted on the CO position.
- Combination 2: CO type 2 and CO type 3**  
CO type 2 must be mounted on the CO position.

See page on how to upgrade the second CO cell.

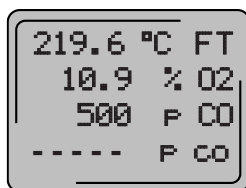
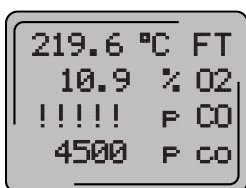

If two CO cells are installed you can switch between the CO cell for the lower CO measuring range and the CO cell for the higher measuring range by switching on the CO rinse (press the <hPa> button when the pump is running). Here the measured value with the lower CO measuring range is blended out with "!!!!!". The measured value from the CO cell with the high measuring range ("co") is displayed simultaneously.

The same happens when the switch-off limit of the CO cell for the lower CO measuring range is exceeded (see the Chapter "Service: CO rinse...").

#### Please note:

In the menu "Service", Submenu "Indication order" both CO cell types must be selected: CO and co or Co and co. Both CO cell types should be located on the same display page.

If the CO rinse pump is stopped (by switching off manually or the CO measured value of the CO cell with the lower CO measuring range is lower than 30% of the switch-off limit) the CO measured value of the CO cell with the lower CO measuring range is again shown in the display.

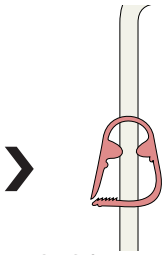

If **testo 350** is operated with the gas preparation unit **testo 339** the hose clamp must be pressed together before the draught is measured.

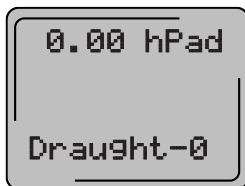

2 - 3 seconds

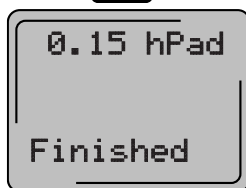
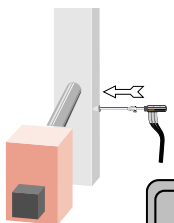
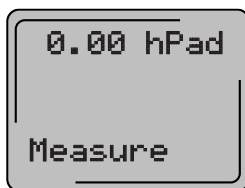

A draught measurement is only possible if the pump is switched off.



Do not switch between battery and mains operation when measuring the draught (fluctuations in the voltage influence the measured result).

If you measure the draught following gas measurement there is a stagnation pressure in the hose which first has to be reduced. This occurs within 30 seconds. Possible condensate residue in the flue gas probe also has to be removed (by shaking).

If the control option **testo 339** is built-in, a hose clamp must always be present in the hose lead when measuring draught to draw in gas for the flue gas probe.

Start the draught measurement by setting the zero point outside the flue in the **measurement menu** via the <hPa> key.

Do not change the position of the analyser once the zero point has been set.

The pressure sensor is calibrated for 2–3 seconds.

Once calibration has finished the current draught measurement is indicated on the display.

Now replace the probe in the flue gas.

As soon as the measured value has stabilised the measurement is ended by pressing <hPa> and the measured value is “frozen”.

A positive display value (eg 0.15 mbar) corresponds to overpressure, a negative display value (eg -0.05 mbar) corresponds to underpressure (draught). The measured value is saved and you jump to the measurement menu after approximately 3 seconds.

### 3 Operating with Gas Preparation

Please read the

**testo 339**

Instruction Manual

If **testo 350** is to be operated together with **testo 339** both instruments must have an electrical connection and the gas paths must be connected before switching on (refer to the **testo 339** Instruction Manual). First switch on **testo 339** and then **testo 350** so that it recognises the connected gas preparation unit.

Condensate occurring during measurements on furnaces carried out over long periods can lead to inaccurate data on the NO<sub>2</sub> and SO<sub>2</sub> present.

The condensate accumulates in the hoses and filters and absorbs NO<sub>2</sub> and SO<sub>2</sub> components.

The **testo 339** gas preparation unit eliminates the condensate in the sample gas without eliminating the NO<sub>2</sub> and SO<sub>2</sub> present.

During continuous measurement over a longer time period the operation of **testo 350** in connection with **testo 339** must be cyclical. Gas measurement (sample time) and fresh air rinses (rinse time) are switched constantly.



```
Self-test
18.8 °C AT
Accu:0000
Time=19
```

```
t339
is not
ready
```

Message 1

```
t339
ready
Confirm
with <E>
```

Message 2

```
Sample tm:
h:m=00.00
Rinse time
h:m=00.00
```

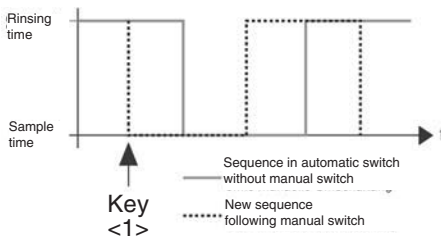

```
Fresh air
t 339
```

```
Gas meas.
t 339
```

If the "Control module" option is installed the **testo 350** automatically recognises when switched on whether the gas preparation is connected or not. A connected **testo 339** is displayed during the self-test phase by **"\*\*"**. Two messages may appear once the self-test phase is over.

- 1) **"testo 339 not ready"**  
The gas preparation unit is still in the warm-up phase. A measurement with **testo 350** is not yet possible. Once the gas preparation unit is ready to operate message 2) is shown. Message 1) cannot be switched off.
- 2) **"testo 339 is ready"**  
The gas preparation unit is ready. Press the <E> key to select the sub-menu "Fuel selection". **testo 350** is now ready to measure and the gas preparation unit is in the fresh air rinse mode.

When operating the gas preparation unit with **testo 350** (with the integrated **testo 339** control module option), the sample times and rinsing times are switched via **testo 350**. You can choose between:

- 1) Automatic switch
- 2) Manual switch

#### 1) Automatic switch:

The programming of the duration of the sample and rinse time in the memory mode is described in detail in the Chapter on "Saving". (refer to Chapter 6, Savng).

This setting is not saved permanently but when **testo 350** is switched off the sampling and rinse times are deactivated.

You can switch manually during automatic operation by pressing the keys <1> and <0>. A manual switch during the automatic mode eg from rinsing time to sample time with the <1> key changes the time sequence of the procedure. The rinsing time is interrupted, a new gas measurement cycle is started which does not correspond to the sample time defined by you in the memory.

The "missing" rinsing time is not extended during the next rinse.

#### Please note the following:

**Manual switching during automatic operation is not possible if at the same time data is being saved cyclically.**

#### 2) Manual switch

to gas measurement by pressing <1>,

to fresh air rinse by pressing <0>.

During manual switching the cycle times of the sample and rinsing times should be set at zero otherwise automatic switching is still active.

The messages opposite are shown for approximately 5 seconds for both manual and automatic switches.



```
219.6 °C #FT
16.9 % #02
11 % #EFFN/EFFG
36 P #00
```



```
219.6 °C *FT
16.9 % *02
11 % *EFFN/EFFG
36 P *00
```

If **testo 350** is operated with **testo 339** the gas preparation unit can be automatically controlled (See 5.2 "Saving", Automatic operation). If automatic operation is activated the running pump is shown as **"#"** in column 8 of the display.

If the measured data is being automatically saved at the same time the running pump is shown as **"\*\*"** in column 8 of the display.

 The measurement of pressure, velocity and humidity is only possible with the Comfort version. The operation mode “Probe mode” is provided only in the Comfort version.



SELF-TEST

FUEL SELECTION



or

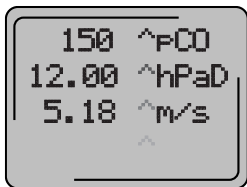

After the instrument is switched on, **testo 350** first runs through the self-test phase. Once the fuel has been selected the instrument automatically jumps to the measurement menu when <Parameters> or <Enter> have been pressed.

Start the pump.

Scroll with the <▲> or <▼> key until the probe connected is shown. The prerequisite is that these parameters are activated in the “Additional functions” menu, under “Setting the indication order” sub-menu.

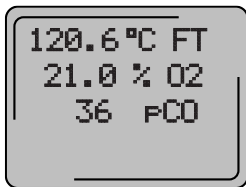

The temperature is measured in the measurement menu only when the pump is operating.

The temperature measured values FT and AT are frozen, like the the flue gas values, when the pump is stopped ie the last measured value remains.

The measurement of pressure, velocity or humidity is continued. The display for these parameters can be frozen in the measurement menu just by removing the probe plug from the hand-held instrument.

The frozen measured value eg for humidity is saved. The pressure probe can then be connected if required.

The pressure probe can be used either for pressure measurement or velocity measurement. Pressure and velocity cannot be measured one after the other and shown in the display.

Once the various measurements have been completed the complete measurement block with flue gas and temperature values can be saved and printed.



During this time the pump should not be started otherwise the frozen measured values for flue gas and temperature will be lost.





SELF-TEST

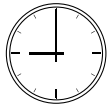

10  
seconds



You can go into the probe mode by pressing the <Start/Stop> key, during the self-test phase, approximately 10 seconds after switching on **testo 350** (remaining operating time <50 seconds).

The advantage is that unlike measurements in the measuring menu you do not have to wait through the whole calibration phase in a normal pressure measurement. Instead you go directly to the measuring mode required.

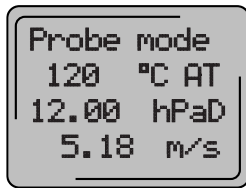

In the probe mode the current values measured by the respective probe connected are shown.

Flue gas values cannot be measured during measurements in the probe mode. The pump is switched off and cannot be switched on again. All of the keys are locked, with the exception of the <On/Off> key.

Measured values cannot be printed, saved or transmitted to the PC in the probe mode.

If a probe is not connected when you jump to the probe mode the two temperature lines appear in the display. Lines appear instead of measured values.

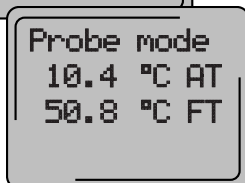
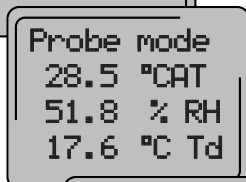
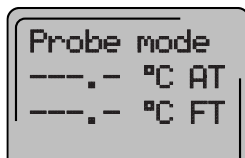

If a probe is connected the instrument recognises it automatically and jumps to the corresponding display.

If the probe is disconnected and a different probe connected you automatically jump to the corresponding display. Automatic recognition may require from 5 to 8 seconds until the corresponding display appears.



The probe mode can only be left by switching off the measuring instrument. The measured values are not saved.

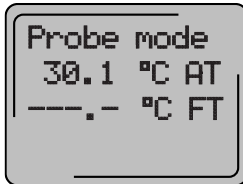

Temperature probes can be connected to the measuring box and to the hand-held instrument, two simultaneously or only one each.

If only one probe is connected only the value of this probe is shown. If, for example, a probe is only connected to a hand-held instrument just the AT of the corresponding value is displayed.

#### Temperature probe

All of the NiCr-Ni and NTC probes can be connected with 8 pin connection plugs available from Testo.

NiCr-Ni sensors are suitable for temperature measurements in a wide measuring range (-200 to +1200°C). Additional advantages include small measurements and very short response times.

Using the NTC sensors, very exact measurements can be carried out in a relatively small measuring range. The measuring range extends from -40 to +70°C.

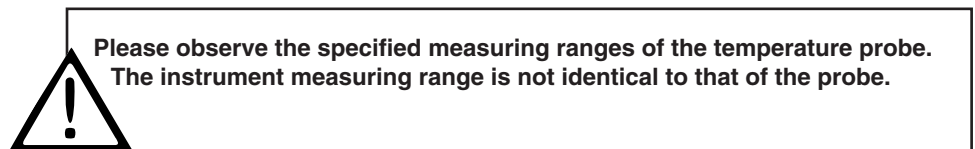

The accuracy of the temperature sensors, type K (NiCr-Ni) correspond to the tolerances specified in DIN IEC 584, Part 2, Class 1 or Class 2. The UNI norm specifications apply to the NTC sensors.

You can choose from four different probe designs: surface, immersion, penetration and air.

## 4 Temperature, Pressure, Velocity, Humidity Measurement

### 4.4 Pressure/velocity measurement

The pressure probes operate with a differential pressure sensor according to the principle of foil strain gauges. In the measuring range 0 to 100 mbar reliable differential pressures can be measured in the higher range and small differences can be measured in the draught range.

The sensor is overload-proof up to 150 mbar. Damage to the sensor can be expected at higher pressures. Likewise measurements with rapid pressure changes should be avoided (eg by switching from compressed air via magnetic valves) since no comment can be made here on the pressure pulse.

Probes which can be connected:

- Differential pressure probe 100 mbar, Order number 0638.1545
- Differential pressure probe 10 mbar, Order number 0638.1445.

Before each pressure and velocity measurement the zero point must be set in the respective pressure probe.



The zero point is set by pressing the <Delete> key.

While setting the zero point  $D = \emptyset$  appears in the display at the bottom left corner (approx. 3 s). When this display disappears the instrument is measuring pressure.

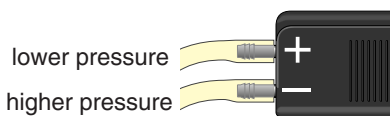

Do not change the position of the pressure probe after setting the zero point.



To measure positive pressures the higher pressure must be applied to the negative input of the differential pressure probe.



#### Measuring ranges

Differential pressure probe 100 mbar: -20 to 100 mbar

Differential pressure probe 10 mbar: -2 to 10 mbar

#### Pitot tubes

Pitot tubes are used with differential pressure meters to measure pressure and velocity. The simplicity of this sensor is its main advantage. The mechanical design of these tubes is stable and robust. Unfavourable ambient conditions such as high temperatures, heavily contaminated air or corrosive gases do not damage the Pitot tube. For extreme conditions a stainless steel version is available (temperature operation range to +500°C). In addition Pitot tubes do not show any wear.

#### Operating principle

Two silicon hoses (refer to Ordering data) connect the Pitot tube with the pressure sensor. The Pitot tube opening absorbs all the pressure (velocity and static) and conducts it to connection (a) in the Pitot tube. Connection (a) is connected to the negative input of the differential pressure probe. The pure static pressure is absorbed via side slots and conducted to connection (b) in the Pitot tube. Connection (b) is connected to the positive input of the differential pressure probe. The resulting differential pressure is the dynamic pressure dependent on velocity. This is analysed and displayed.

If the pressure is to be converted to velocity values the Pitot tube factor and the ambient air pressure must be entered before starting the measurement (refer to Chapter 10.3, Calculation Information). By pressing <Scroll> this can be set in the Additional functions menu under Factors, Pitot tube measurements. In the probe mode you jump here directly via <Scroll>.

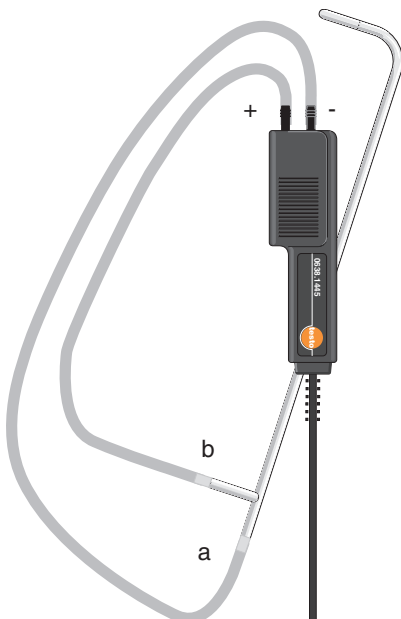

## 4 Temperature, Humidity, Velocity, Pressure Measurement

The third parameter which the measuring instrument must be familiar with to convert differential pressure to velocity is the temperature of the flowing gas.

This temperature is the basis for the density compensation which must be carried out for the conversion (refer also to Chapter 10.3, Calculation Information).

In the measuring mode this temperature is measured via the thermocouple of the flue gas probe or via a separate temperature probe.

This means that in the measuring mode the velocity is always measured with the pump running parallel to temperature measurement.

Likewise in the probe mode, in addition to the pressure probe with Pitot tube the temperature of the flowing gas should always be measured via a temperature probe connected to the measuring box.

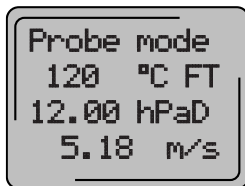
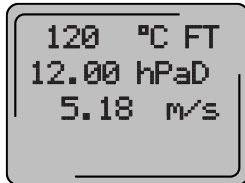

There can be no conversion to m/s in both the measuring and probe mode without a parallel temperature measurement.

### 4.5 Humidity measurement

A capacitive humidity sensor is combined with an NTC temperature sensor in this probe. The humidity sensor measures the relative air humidity according to the capacitive principle. The relative air humidity is a measure for the water vapour content in the air and in gases. The relative humidity is the ratio of the available absolute humidity to the maximum absolute humidity possible at the same temperature.

The relative humidity and temperature are measured simultaneously if the humidity probe is connected, the dew-point is then also calculated.

#### General Operating Instructions

Depending on the application you can choose from 2 different versions:

Air probe for ambient humidity,  $T_{\max} = +70^{\circ}\text{C}$  (0636.9767)

and high temperature probe,  $T_{\max}$  continuous use =  $+140^{\circ}\text{C}$  (0636.2167), to measure the humidity in flue gas.

For measurements in highly contaminated, corrosive or very humid flue gas the stainless steel sintered cap fitted in the factory should be replaced by a Teflon sintered filter to protect the sensor (refer to Ordering data).

#### Maintenance

Humidity probes do not require maintenance if they are used in a "clean" environment. If this is not the case eg measurements in a dusty, corrosive environment the humidity probes should be checked regularly.

We recommend the control and calibration set listed in our Ordering data when checking and calibrating the humidity probes (refer to the maintenance chapter, Humidity calibration).

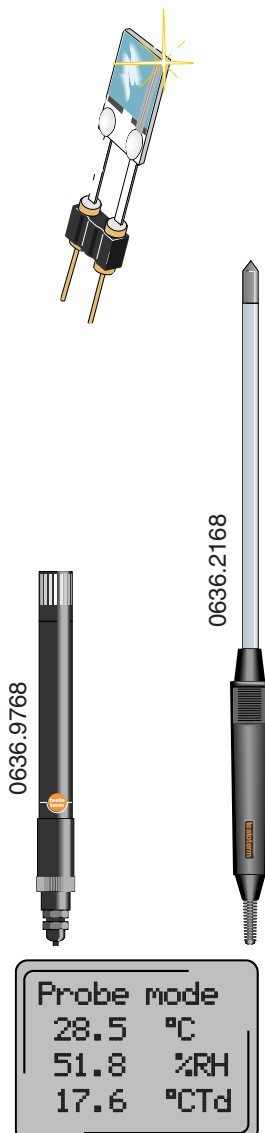

Display in probe mode.

The option of saving measured values is offered only by the Comfort version.

**Please note:**

- Only the measured values marked (+) in the sub-menu Indication order are saved. The measurement location must not be activated. It is saved automatically. The values are saved in accordance with the set indication order. If all of the values have been deactivated ("-") the data and data sets are not saved. (See "Service" menu, "Indication order" sub-menu). A jump to a sub-menu in the memory mode is not possible.

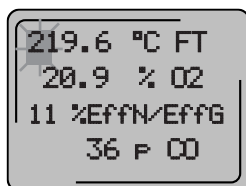

- If you are in the save menu the pump cannot be started.
- If measured values are brought from the memory to the display the upper left segment always flashes. The display is moved up or down one line by pressing the keys < ▼ >, < ▲ > ie the measured values are shown line by line unlike in the measurement menu where they are shown screen by screen.

A maximum of 50 data sets can be saved with the measurement location.

You have the possibility of saving a measured value block manually or of assigning a complete measurement series to a single measurement location name.

**10** *Summary of manual operation*

- End measurement by pressing Stop pump
- Input measurement location name
- Saving

**11** *Summary of automatic operation*

- Input scan rates
- Input measurement location name
- Start measuring and saving (Pump ON)
- **testo 350** saves in the programmed cycle
- End measuring and saving (Pump STOP)
- When automatic saving is operating the pump symbol, a moving arrow, is replaced by a
  - moving rectangular symbol (□) during measurement without a gas preparation unit (testo 339)
  - moving star "\*" during measurement with a gas preparation unit.

**Manual operation**



End your measurement by pressing <Start/Stop>.



If you want to save the displayed measured values call up the Saving sub-menu by pressing the <Memory> key.



The cursor is on "Enter" which you confirm by pressing <Enter>.

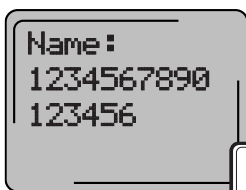

Under "Name" enter your measurement location name (customer number, name of location) with maximum of 16 characters, confirm by pressing <Parameters>.

If the name already exists the message "Overwriting not possible" appears. This message must be confirmed by pressing <Enter>. Please use a different name. By pressing <Parameters> you go from the saving menu back to the measurement menu. The last "frozen" measured value block is displayed again.

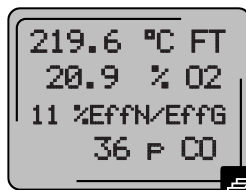

Save this measured value block by pressing <Memory> under the measurement location name which has just been entered.

The message "Memory" appears in the display as confirmation.



**testo 350** then goes into the measurement menu. Press the <Memory> key, **testo 350** jumps to the Saving menu since only one measured value block can be saved under a measurement location name.

If you wish to save several measuring blocks in one location use an index for the measurement location name eg Testo 1, Testo 2 which you can allocate continuously under Enter.

Menu Saving 

```
Automatic
Enter
Selection
```

Sub-menu  
Auto (1)

```
Scan rate
mm:ss
00:00
Average:±
```

Sub-menu  
Auto (3)

```
Print when
storing:-
Time left:
h:m=01:15
```

Sub-menu  
Auto (2)

```
Sample tm:
h:m=00:10
Rinse time
h:m=00:30
```

**Automatic operation**

Press <Memory> to call up the "SAVING" menu.

Select the sub-menu "Automatic saving".

You can then specify the data in several menus in relation to automatic saving.

The scan rate is input in the display opposite (ie the time between each saving process). The shortest time unit is 10 seconds, the longest 39 minutes 50 seconds. If a scan time was not set (scan rate: 00:00) **testo 350** jumps back to the Saving memory. Automatic saving cannot be started.

The 4th line can be set such that when the scan time has expired the current measured value or the average is saved (averaging does not take place during the fresh air rinsing of the CO measuring cell). Only those values or averages are saved which have been released for saving with "+" in the Service sub-menu "Indication order".

"-" = : The value measured once the scan time has expired is saved.

"+" = : The average taken after the scan time has expired is saved.

To determine the average, the values are measured at a fixed interval of 30 seconds. The scan time must be set at more than 30 s otherwise the display cannot be quit via the parameter key. The scan rates should be in multiples of 30 seconds.

+ or - is selected via <▼> and <▲>.

The settings are confirmed by pressing <Parameters>. If a gas preparation unit is connected you jump to the Auto sub-menu (2). If a gas preparation unit is not connected **testo 350** jumps to the sub-menu Auto (3). Here you can set whether the measured values are to be printed during saving. "+" or "-" can be selected via <▼> and <▲>:

"-" = : Only measured values are saved.

"+" = : Measured values are saved and simultaneously printed.

Please note:- the scan time for simultaneous saving and printing must be at least 1 min 20 s.

- averaging must be deactivated (average: "-")

The time remaining is displayed on the 4th line and remains here until the memory is full ie the maximum duration of your measurement series.

Example: scan rate: 2 minutes: this setting ensures that 30 measured values are saved per hour. This measuring cycle can be maintained for 2 hours. (See "Calculating the memory capacity")

The settings are confirmed via <Parameters>.

**Controlling the gas preparation unit** (prerequisite: Software version 2.0 in **testo 339**)

If the control module for the gas preparation unit is integrated in the analyser and the gas preparation unit is connected, by pressing <Parameters> you will jump to the Sub-menu Auto (2) after the scan time and the average are entered. The scan times for the gas preparation unit are set here.

Sample time: Time during which the measuring cells come into contact with flue gas (can be set in hours and minutes).

Rinse time: Time during which the measuring cells are rinsed with fresh air and when the measuring cells regenerate (can be set in hours and minutes)

The shortest time unit which can be set is 5 minutes, the longest 4 hours. For pollutant concentrations greater than 500 ppm a sample time of more than 30 minutes should not be exceeded.

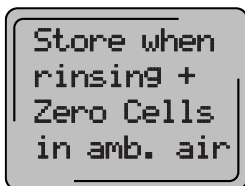

Sub-menu  
Auto (3)

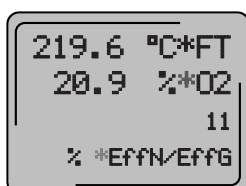
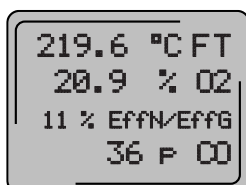
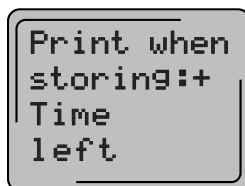

Once the data has been accepted by <Parameters> the menu “Store when rinsing” appears. Here many different additional commands can be entered in the rinse phase. “+” and “-” can be selected via <▼> and <▲>. With “Store when rinsing” you can determine whether the measured values are to be saved during rinsing.

“-” =: The measured values are not saved during rinsing time.  
 “+” =: The measured values are saved during rinsing time.

With “Auto-O when rinsing” you can select whether the measuring cells are to be zeroized during rinsing or whether a fresh air admission without zeroizing the cells is carried out. “+” and “-” can be selected via <▼> and <▲>.

“-” =: Fresh air admission without zeroizing of the cells.  
 “+” =: Zeroizing of the measuring cells during the rinsing phase.

Once the data has been accepted by <Parameters> the sub-menu “Auto (3)” is displayed. Here you can determine whether the measured values are to be printed during saving. “+” and “-” can be selected via <▼> and <▲>.

“-” =: Only measured values are saved  
 “+” =: Measured values are saved and printed simultaneously.  
 Please note: - the scan time for simultaneous saving and printing must be at least 1 min 20 s.  
 - averaging must be deactivated (average: “-”)

If the complete memory is available, 50 measured value blocks can be saved depending on the number of measured values to be saved. During automatic saving the gas preparation unit cannot be manually controlled (See Chapter “Operating with Gas Preparation”).

Once all the values for automatic saving have been entered you jump back to the save menu by pressing <Parameters>. The measurement location name is entered in the sub-menu “Enter”. Change to the measurement menu by pressing <Parameters> twice and begin automatic saving by switching on the pump (<Start/Stop>).

The automatic saving operation is shown in column 8 in the display by a  
 - rectangle going from the bottom to the top if the gas preparation unit is **not** connected  
 - star going from the bottom to the top if the gas preparation unit **is** connected  
**(testo 339)**

*Note on operation with the gas preparation unit:*

The first cycle is generally the cycle during which the measuring cells come into contact with flue gas (sample time).

Finish the measurement and automatic saving operation by stopping the pump with <Start/Stop>. Additional measured values cannot be saved under the measurement location name last saved. The scan rate is automatically deactivated. Sample and rinse time values remain saved until the instrument is switched off. For additional measurements enter the new measurement location name and set the new cycle.

**All time specifications i.e. scan rate, sample time and rinse time are set to zero or deactivated when testo 350 is switched off.**



### Selecting saved measured values



```
Automatic
Enter
Selection
```

```
79853TEST0
79853J.Mai
79853T.Grü
90853ALBER
```

```
79853TEST0
D:03.08.94
T:10:45.00
S: 001/001
```

```
79853TEST0
D:03.08.94
T:10:45.00
S: 001/008
```

```
O2
CO
...
219.6 °C FT
20.9 % O2
11 %EffN/EffG
36 P CO
```

Regardless of whether the measured values are manually or automatically saved the following procedure is identical for both.

Call up the measurement menu from the Save menu by pressing <Memory> and select the sub-menu "Selection".

The list of saved measurement location names appears. The first 10 characters of a customer number are displayed. The remaining 6 numbers can be displayed by pressing <hPa>. The display switches by 6 characters to the right. Select the required measurement location name with <▼>, <▲> while pressing the <Enter> key. The next display again shows which measurement location was selected and gives information on the date and time of the first measurement. (3rd August 1994, 10:45). With manual saving, the time (T) is the real time of the saving process and after "S" the following is specified: first measured value block/of a measurement series with one measurement.

In the automatic mode the time is the starting time of the saving cycle. Select after "S", via the keyboard, left of the slash, which measured value block you wish to display. To the right of the slash you will see how many measured value blocks are contained in the measurement series. There are **eight** in our example.

You can call up a measured value block from the memory by pressing <Parameters>. It gives a signal that they are measured values taken from the memory to be displayed.

If exclamation marks "!!!!" appear with the CO measured value this means that the averages have not been saved because the CO measuring cell was rinsed with fresh air during measurement.

You can look at all of the measured values of the measured value block shown on the display by pressing <▼>, <▲> and you can print the complete measured value block including date/time by pressing <hPa>.

Press <Parameters> to return to the measurement menu.

### Deleting measured values and measurement location names

The complete data set (measured value block and measurement location name) is deleted. To do this select the list of measurement location names in the Enter/Selection sub-menu via Selection.

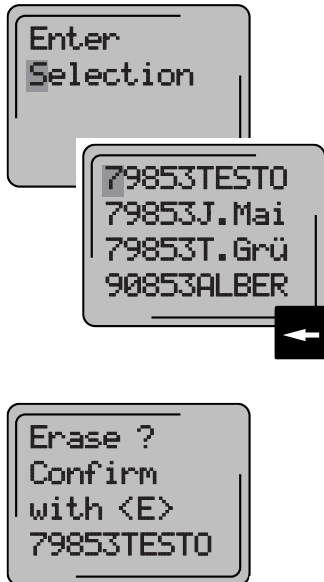

Select the measurement location name which you wish to delete including the saved measured value block and press the <Delete> key.

You are asked to confirm by the question opposite. The complete data set is deleted by pressing <Enter>. <Scroll> cancels the process. You then go to the Memory sub-menu.

The whole memory content can be deleted in the Service menu, Save mode sub-menu (refer to the Chapter on Additional functions).

## 5.1 Calculating the memory capacity

The following factors are decisive in the calculation of the number of data sets to be saved.:

- Number of measured values or data to be saved  $n_M$  (max. 36 parameters)
- Number of customer names / customer numbers or measurement location  $n_K$  (max. 50 customer names/numbers can be input)
- Total size of the memory available in the hand-held instrument (24 544 bytes)

Memory required by a data set

A data set consists of the number of measured values, e.g. FT, AT, Lambda, qA, O<sub>2</sub>, CO<sub>2</sub>, CO, NO, NO<sub>2</sub>, SO<sub>2</sub>.

$$\text{Data set} = (n_M \times 5 \text{ bytes}) + 3 \text{ bytes}$$

Memory required by a customer number or customer name:

$$\text{Data head} = 120 \text{ bytes / customer number (constant)}$$

Example:

How many data sets can be saved under a customer number during the ring saving of 10 measured values?

$$\text{Formula:} \quad \frac{(\text{Size of memory} - (n_K \times 120 \text{ bytes}))}{\text{data set}}$$

Size of memory: 24 455 bytes

Data set: (10 x 5 bytes) + 3 bytes = 53 bytes

Memory requirement

Customer number: 120 bytes

$n_K$  (number of customer numbers): 1

→ 459 data sets can be saved.

### MEASUREMENT MENU



### ADDITIONAL FUNCTIONS

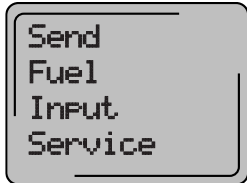

You can go to Additional functions from the measurement menu by pressing the <Scroll> key. The additional functions are made up of four menu points.

Sub-menu	Function
Send	Control of the transfer of the measured values to an infrared printer.
Fuel	Selecting the fuel
Input	Input of the <ul style="list-style-type: none"> <li>- fuel-specific values CO<sub>2</sub> Max und O<sub>2</sub> reference</li> <li>- and of freely available fuels,</li> <li>- measured soot values</li> <li>- heat carrier temperature</li> <li>- oil derivatives</li> </ul>
Service	Determining the operation procedure

### 6.1 Send

Sub-menu  
Send

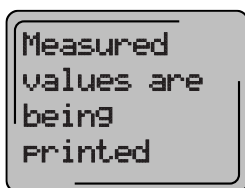

The measured values and input values can be printed on the infrared printer (available as accessory)  
Start printing by pressing <E>.

#### a) Printing on the infrared printer

##### Printing current measured values

Once measurement has been ended by stopping the pump (<Start/Stop>) go to the "Additional functions" menu by pressing <Scroll> and select "Print" from the "Send" sub-menu.

Start printing by pressing the <E> button. All of the measured values and all of the inputs activated (e.g. soot value) **which were selected in the order indication** are printed on the infrared printer (See separate Instruction Manual on how to operate the infrared printer).

When printing current values all of the values selected in the indication order are printed **once** in the order in which they were saved in the sub-menu "Indication order" (see "Service" menu, "Indication order". When printing saved measured values the complete saved data set is printed.

Printing can be interrupted by pressing <Scroll>.

##### Printing saved measured values

Select the data block required from the memory and then you can start printing

- by pressing <E> and the measured values in the display are printed or
- by pressing <hPa> and the complete measuring sequence is printed (See Chapter 5 "Saving").

## Printout on infrared printer

## Current values

```

testo GmbH &Co.
73849 Lenzkirch
----- testo 350 -----
09.11.94          13:07:08
  22.3          °C FT
   8.5          % CO2
  ----          % %A
   9.5          % O2
  426           P CO
  1.83          X
   778          PuCO
Heat. Oil EL
  9.5          % O2
  22.5         °C AT
  22.3         °C FT

Soot/Oil deriv.    -oild.
  1: 1  2: 2  3: 1  ] 1
----- testo 350 -----

```

Printout when saving  
Scan time: 2 min

```

testo GmbH &Co.
73849 Lenzkirch
----- testo 350 -----
09.11.94          15:52:27
  23.6          °C FT
   6.8          % CO2
  ----          % %A
  11.7          % O2
  351           P CO
   2.26         X
   795          PuCO
Heat. Oil EL
  11.7          % O2
  27.8         °C AT
  23.6         °C FT

Soot/Oil deriv.    -oild.
  1: 1  2: 2  3: 1  ] 1
----- testo 350 -----

testo GmbH &Co.
73849 Lenzkirch
----- testo 350 -----
09.11.94          15:54:28
  22.7          °C FT
  ----          % CO2
  ----          % %A
  20.9          % O2
   2           P CO
  ----          X
  ----          PuCO
Heat. Oil EL
  20.9          % O2
  27.8         °C AT
  22.7         °C FT

Soot/Oil deriv.    - oild.
  1: 1  2: 2  3: 1  ] 1
----- testo 350 -----

```

Saved values  
without averaging

Meas. sequence: 0149021102544001  
Data set no.: 7 to 10 (end)

```

testo GmbH &Co.
73849 Lenzkirch
----- testo 350 -----
09.11.94          15:39:13

Zykluszeit          00:20

0149021102544001

No. : 7

  27.2          °C FT
  ----          % %A
   1.4          % O2
  1042           P CO
   1.07         X
Heat. Oil EL
  27.8         °C AT

No. : 8

  29.2          °C FT
  -3.5          % %A
   1.4          % O2
  1043           P CO
   1.07         X
Heat. Oil EL
  27.8         °C AT

No. : 9

  28.6          °C FT
  -3.6          % %A
   1.4          % O2
  1042           P CO
   1.07         X
Heat. Oil EL
  27.8         °C AT

No. : 10

  24.8          °C FT
  ----          % %A
   1.4          % O2
  1041           P CO
   1.07         X
Heat. Oil EL
  27.8         °C AT

Soot/Oil deriv.    -oild

  1: 1  2: 2  3: 1  ] 1
----- testo 350 -----

```

Saved values  
with averaging

Meas. sequence: boiler 2  
Data set no.: 1 bis 3 (end)

```

testo GmbH &Co.
73849 Lenzkirch
----- testo 350 -----
09.11.94          15:32:04

Scan rate           02:10

Boiler 2

No. : 1           Average:

  22.9          °C FT
  ----          % %A
   2.1          % O2
  216           P CO
   1.11         X
Heat. Oil EL
  27.8         °C AT

No. : 2           Average:

  22.4          °C FT
  ----          % %A
   1.4          % O2
  1039           P CO
   1.07         X
Heat. Oil EL
  27.8         °C AT

No. : 3           Average:

  22.4          °C FT
  ----          % %A
   1.4          % O2
  1048           P CO
   1.07         X
Heat. Oil EL
  27.8         °C AT

Soot/Oil deriv.- oild.

  1: 1  2: 2  3: 1  ] 1
----- testo 350 -----

```

#### Data transfer to PC

##### Please read the Instruction Manual on your PC program.

Set up the connection between the hand-held instrument and the PC via the interface cable.

The data is read via the PC and the appropriate software. The procedure is described in the Software Instruction Manual. The PC program reads the data from the hand-held instrument. **This can take place in every menu.** The user is not required to set anything on the hand-held instrument.

The complete customer data can be transferred to the PC.

If the serial interface cable is plugged in the infrared transfer option is blocked.

### 6.2 Fuel

#### Changing the fuel type during or after measuring.

A selection with the most common fuels appears. Their parameters are stored in the memory of the measuring instrument. The fuel chosen last remains after the measuring instrument has been switched off.

#### SUB-MENU Fuel

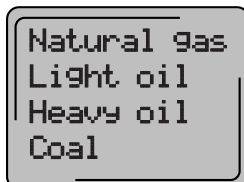

Fuel	$K_{gr}$	$K_{net}$	$CO_{2max}$	$K_1$	Hydrogen Content of fuel H	Moisture Content of fuel $MH_2O$	$Q_{gr}$	$Q_{net}$	$O_2$ ref	$F_{Br}$
Natural Gas	0.350	0.390	11.9	40	24.4	0	53.42	48.16	3	0.2304
Fuel Oil Class D	0.480	0.510	15.5	53	13.0	0	45.60	42.80	3	0.2434
Fuel Oil, Class E,F&G	0.510	0.540	15.8	54	11.5	0.2	42.90	40.50	3	0.2545
Coal	0.620	0.650	18.4	63	4.0	13.0	26.75	25.50	6	0.2561
Anthracite	0.670	0.690	19.1	65	3.0	12.0	29.65	28.95	6	0.2551
Coke LPG	0.750	0.760	20.6	70	0.4	10.0	27.9	27.45	6	0.2919
Propane LP	0.420	0.450	13.8	48	18.2	0	50.0	46.3	3	0.2341
Butane	0.430	0.460	14.1	48	17.2	0	49.30	45.80	3	0.2301
Fuel 1	0.350*	0.390*	11.9*	40*	24.4*	0*	53.42*	48.16*	3*	0.2304
Fuel 2	0.480*	0.510*	15.5*	53*	13.0*	0*	45.60*	42.80*	3*	0.2434

\* can be freely selected (refer to Chapter 8, Input sub-menu  $O_2$ ref/ $CO_2$ M)

$K_{gr}$ ,  $K_{net}$ ,  $CO_{2max}$ ,  $K_1$ ,  $K_2$ , Hydrogen content of fuel H, Moisture content of fuel  $MH_2O$ ,  $Q_{gr}$ ,  $Q_{net}$ ,  $O_2$  ref are all fuel-specific factors  
 $F_{Br}$  Conversion factor  $g/m^3$  in  $g/GJ$

SUB-MENU

Input

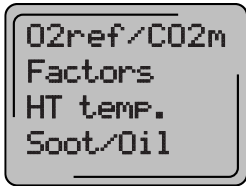

**O<sub>2</sub>ref./CO<sub>2</sub>m**

When initiated the selected fuel is shown on the display with its current values for the **O<sub>2</sub> reference value** and **CO<sub>2</sub> max**.

This data can be changed. Refer to Chapter Key assignment "Entering numbers".

"T" appears in the last column if the reference value corresponds to the value in the fuel table (refer to Setting). "D" appears if the value deviates.

If the values were changed "T" and "D" can only be updated when you jump back to this sub-menu via Additional functions.

If 0.00 or 00 is entered the measuring instrument returns to the factory setting.

The set values are saved by pressing <Parameters>.

SUB-MENU

O<sub>2</sub>ref/CO<sub>2</sub>m

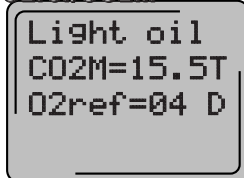

**Factors**

Input of the fuel-specific factors (for the user fuels of your choice)

The name of the freely selectable fuel is in the top line. The values can be entered as described in the Chapter "Entering Numbers".

If a predefined fuel is set ie not Fuel 1 or Fuel 2, lines appear in the input line; it is not possible to enter or change the factors for these fuels. HO =18.80

The conversion factor from mg/m<sup>3</sup> to g/GJ is FB. From this you can calculate the conversion to mg/KWh (see Calculation Information).

SUB-MENU

Factors

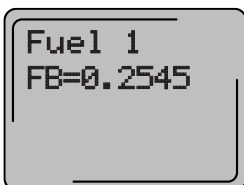
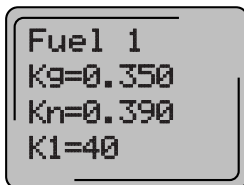

SUB-MENU

HT temp



**Input of heat carrier temperature**

Enter the heat carrier temperature which was measured separately (eg boiler water temperature).

SUB-MENU

Soot/Oil

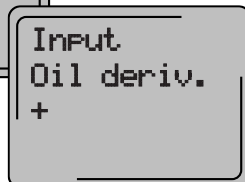
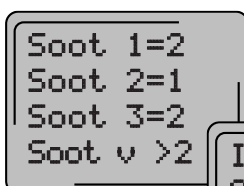

**Soot/Oil deriv.**

Three soot values can be entered in lines 1 to 3. The average value of the three values is calculated in the 4th line. The Ø soot value is saved by pressing <Parameters> and then the system transfers to the input menu "Oil deriv".

"+" = YES – oil derivatives available

"-" = NO – oil derivatives not available.

Select by pressing <▲>, <▼>.

Press Parameter to jump back to the input menu.

“Service” includes the settings or information which influence operation functions.

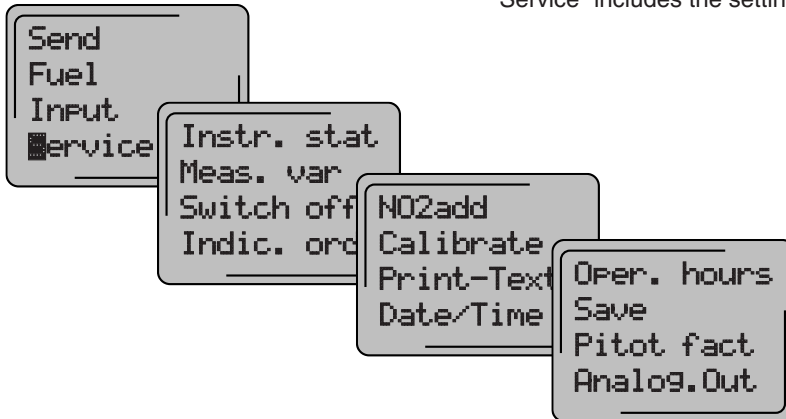

#### SUB-MENU Instrument status

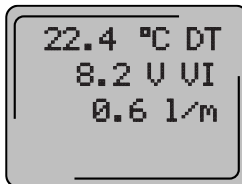

#### Instrument status

The data required for smooth operation such as **instrument temperature**, **rechargeable battery voltage**, **pump capacity** (with the built-in **testo 339** control module option) and **NO counter** (with built-in NO cell) are indicated so that they can be checked.

- DT = Temperature of analyser  
(Perm. operating temperature +4 to +40°C)
- VI = Rechargeable battery power of the analyser  
(Lower limit 6.6V)
- l/m = Pump capacity (0.5 – 1.2 l/min)  
The pump capacity should never go below 0.5 l/min.

#### SUB-MENU Meas. var

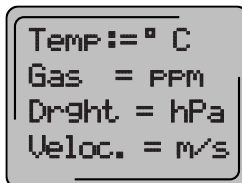

#### Measuring variables

Jump from line to line by pressing <Enter> and select the required measuring variable via <▲> or <▼>.

- You can select from the following measuring variables :
- Temperature: °C / °F;
  - ① Flue gas: ppm, mg/m<sup>3</sup>
  - ④ Draught/differential pressure: mbar, hPa, Pa, γH<sub>2</sub>O
  - Velocity: m/s, ft/m



SUB-MENU  
Switch-off

```
CO :02500
NO :02500
NO2:00350
SO2:03500
```

### Switch-off limits

#### Setting

To protect the measuring cells the gas pump switches off automatically at high concentrations (the CO cell is automatically rinsed with fresh air if there is a built-in CO rinsing function).

Limit values (in ppm) for these reactions can be programmed in for the measuring cells CO, NO, NO<sub>2</sub> and SO<sub>2</sub>.

If the setting 0000 is programmed this function is switched off.

**WARNING. There is a danger of the measuring cells being destroyed if concentrations are too high.**

Ranges of the limit values:	Factory setting
CO type 1: 0 to 10000	2.500
CO type 2: 0 to 20000	15.000
CO type 3: 0 to 40000	30.000
NO: 0 to 3000	2.500
NO <sub>2</sub> : 0 to 500	350
SO <sub>2</sub> : 0 to 5000	3.500

The cells are offered according to how the analyser is equipped.

#### Exceeding the switch-off limits

If a measuring cell is overloaded the pump stops and "^^^" appears in the display instead of the measured value. ^

#### Exceeding the switch-off limits with connected gas preparation (testo 339)

If **testo 350** is operated with the gas preparation unit (**testo 339**) **testo 350** remains *in automatic operation* in the gas measuring phase until complete, as specified. If you switch to fresh air the pump starts automatically and **testo 350** remains on fresh air until the cells are automatically zeroised. The setting "Auto-0" in the saving mode, sub-menu "Storing when rinsing" does not play a role in this case. *In manual operation* the fresh air rinse must be started with <0>. The cells are rinsed with fresh air until the pollution values allow the measurement to continue.

#### CO rinse

If the CO rinsing function (optional) is built-in and the limit values specified by the switch-off limits (see above) have been exceeded the CO cell is automatically separated from the gas path and rinsed with fresh air. Once the concentration in the measuring cell has gone below 30% of the limit value, the fresh air rinse is switched off and the CO cell is connected to the gas path.

The CO rinsing function can be switched on or off manually when the measuring pump is on by pressing the <hPa> key. "!!!!" appears in the display instead of the measured value.

```
^^^^^ P NO
121.5 °C FT
17.4 % O2
50 P SO2
```

```
!!!! P CO
20.3 °C AT
17.4 % O2
50 P NO2
```



#### Indication order

##### SUB-MENU Indication order

01.FT	+
02.AT	+
03.%O2	+
04.NO	-

(Comfort version)

01.%O2	+
02.AT	+
03.NO	+
04.%O2	-

Determine the indication order of the measured values in a measuring block according to your own requirements. Select the line you want changed by pressing <Enter>. Press <Enter> and the cursor jumps to a description of the unit displayed. Now select the unit required by pressing <▲>/<▼>. Confirm by pressing <Enter>. The settings are saved by pressing <Parameters> and you can jump to the next selection window in the indication order. A maximum of 9 windows with 4 lines each can be programmed. Following confirmation with <Parameters> the settings are saved. This procedure can take up to one second before a jump to the next window is possible.

The procedure can be cancelled by pressing <Scroll>.

*In the Comfort version you also have the possibility of determining which parameters should be stored.*

" + " - save

" - " - do not save.

*The measured values are set at "+" on delivery.*

*If all of the parameters are marked with "-" the data cannot be saved and data which has already been saved cannot be selected.*

*After selecting the parameter you will not jump to the next line when <Enter> is pressed. You will instead jump to the selection point "save/do not save".*

*+ and - are selected with <▲> and <▼>.*

*Each measured value is saved only once even if it is selected several times in the indication order. The last selected setting applies (in the example opposite "-" would apply to "%O2").*

*Now, when you press <Enter> you jump to the next line.*

*The settings are saved by pressing <Parameters> and you can jump to the next selection window in the indication order. The procedure can be cancelled by pressing <Scroll>.*

The following measured values can be displayed

FT	Flue gas temperature
AT	Combustion air temperature
%O2	Vol % oxygen
%CO2	Vol % carbon dioxide
EffN/EffG	Net/gross efficiency
λ	Excess air value
CO	Carbon monoxide (CO type 1)
Co	Carbon monoxide (CO type 2)
co	Carbon monoxide (CO type 3)
uCO	Carbon monoxide undiluted
NO	Nitrogen oxide
NOx	Nitrogen oxides NOx
NO2	Nitrogen dioxide
SO2	Sulphur dioxide fuel
Fuel	Fuel selected
Soot	Average of the 3 soot values entered
Oil	Setting the oil derivative 'yes' (+) or 'no' (-)
HTT	Heat transfer temperature input
O2rf	O <sub>2</sub> reference value for the fuel selected (only with mg/m <sup>3</sup> )
CO2m	CO <sub>2</sub> max. value of the fuel
d	Draught
Imin	Pump capacity (only with built-in 339 option)
rat	ratio [COppm/CO <sub>2</sub> % – 100%]
<i>The Comfort version also includes the following:</i>	
D	Differential pressure
m/s	Velocity
%RH	Relative humidity
°CRH	Humidity probe temperature
Td	Humidity probe dew-point
No	Measurement location name

Four measured values are displayed in each window.

SUB-MENU  
NO2add

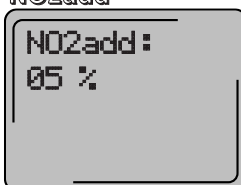

**NO<sub>2</sub> addition**

If, in the analyser there is no NO<sub>2</sub> cell you can add a percentage to the NO reading to give a NO<sub>x</sub> value. This value is set at 5% on delivery if an NO<sub>2</sub> cell is not built-in.

NO<sub>x</sub> is then calculated as follows:  

$$NO_x = NO_{\text{measured}} + (NO_2 \text{ addition}\% \times NO_{\text{measured}})$$

The set NO<sub>2</sub> addition remains even after the instrument has been switched off. If an NO<sub>2</sub> cell module is built-in "-----" appears; it is not possible to input a value.

SUB-MENU  
Calibration

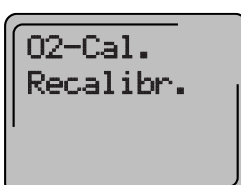

**O<sub>2</sub> calibration**

You can automatically calibrate a new O<sub>2</sub> measuring cell under O<sub>2</sub> calibration. (See Maintenance manual, Chapter Changing measuring cells).

**Recalibration**

You can recalibrate the CO, NO, NO<sub>2</sub> and SO<sub>2</sub> measuring cells yourself under recalibration (as described below).

**testo 350** is calibrated in the factory so that the accuracies described in the Technical data can be measured over the whole measuring range. With recalibration using sample gas the measuring instrument can be recalibrated for the measuring ranges needed or the accuracy of reduced measuring ranges can be increased.

#### Example

An exact NO measurement must be made in the range from 200–300 ppm. Before the measurement a check is carried out with the corresponding sample gas concentration (eg 300 ppm NO). If there is a large deviation recalibration should be carried out as follows.

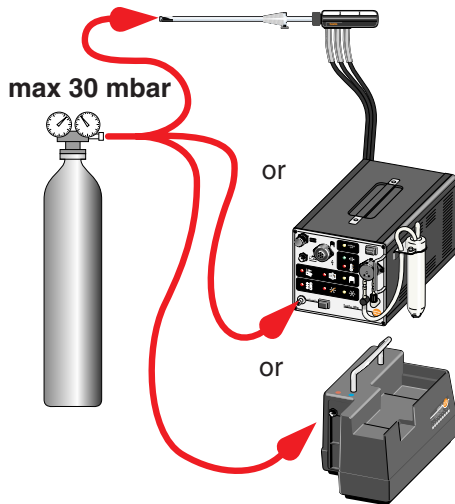

**ATTENTION**

Please observe all safety and accident prevention regulations when handling sample gas.

Sample gas should only be used in well ventilated rooms.

#### Note

With recalibrations in the range < 500 ppm there may be deviations in accuracy in the upper measuring range.

#### Setting up the test

Connect the sample gas to the gas inlet of the connected flue gas probe or directly to the gas inlet of the measuring box or to the gas preparation unit **testo 339**.

The sample gas should be introduced to the measuring instrument at low pressure, if possible (maximum 30 mbar, observe the pressure gauge on the gas bottle). However a flow-through should always be present so that leaked air is not drawn in. Monitoring the flow-through using a rotameter works to your advantage.

Calibration can also be carried out using a gas balloon. When calibrating NO, NO<sub>2</sub>, SO<sub>2</sub> you should ensure that the material in the gas balloon does not absorb gases.

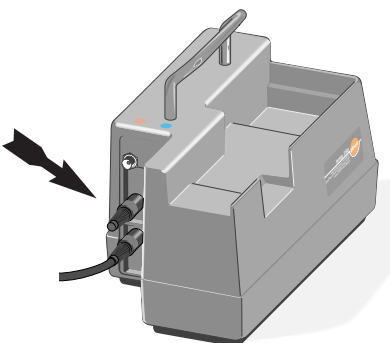
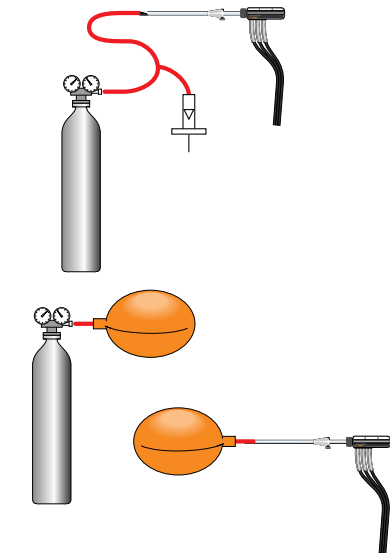

The cell coefficients are write protected. To change these parameters the calibration plug supplied must be plugged in instead of the thermocouple plug for the duration of the calibration.

**To guarantee uninterrupted power supply use of a mains unit is recommended.**

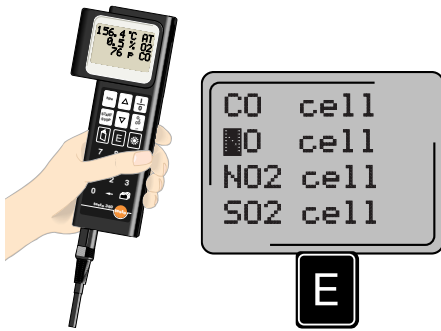

Switch on the measuring instrument. When the self-test phase is over select the sub-menu "Recalibration" in the "Service" menu and then select the measuring cell which is to be recalibrated.

Confirm the selection via <Enter>.

Enter the gas concentration of the sample gas (in ppm) eg 500 ppm NO.

Connect the 8-pin service plug (grey) to the measuring box (flue gas probe symbol).

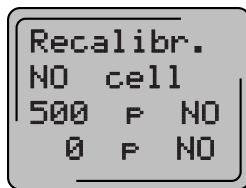

Start the pump by pressing <Start/Stop>. In the bottom line you will see the value measured compared with the reference value (3rd line).

Release the sample gas without pressure (max. 30 mbar).

If this measured value is stable after 5 minutes (eg 480 ppm NO) press <Parameters>, the measured value is saved and the measuring instrument calculates the correction factor.

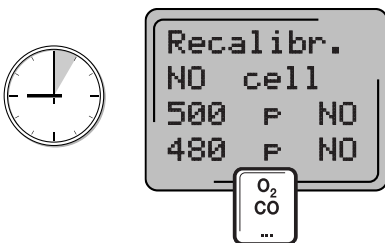

You are required to remove the service plug. The instrument then jumps to the main menu.



#### Note

If after several recalibrations the measured value shown is still too low the measuring cell must be changed.

You can exit the menu at any time by pressing <Scroll>.



## 6 Additional functions menu

### 6.4 Service

#### SUB-MENU Print-Text

```
Line1:  
Testo Ltd.
```

```
Line2:  
79849  
Lenzkirch
```

#### Print-Text (max. 24 characters)

The respective letter, special character or digit is selected in the fields with <▲>. By pressing <hpa> you can switch between upper and lower case and digits. *The numbers in the Comfort version can also be input via the number keyboard.* You can jump to the next position by pressing <▼>. The line is saved via <Parameters> and then you jump to the next line. Input is carried out in the same way. Input can be interrupted by pressing <Scroll>. If the order to cancel comes in the 2nd line the 1st remains saved.

Editing is carried out in the same way as input. In the existing text, the cursor is moved to the position to be edited via <▼> and is then changed via <▲> (or the number keyboard). You can jump to the 1st position of the text via <Enter>. The process is confirmed by <Parameters>, **testo 350** jumps to line 2. The procedure is the same as above.

#### SUB-MENU Date/Time

```
Time=  
15:02:00  
Date  
07:07:94
```

#### Time / Date

The time is input in the format: hh:mm:ss. The date has the format DD:MM:YY (see Input of numbers). If a date or time is entered which is not permitted eg (15:99:00) the entry is not accepted and the cursor jumps to the first input digit.

#### SUB-MENU Operating hours counter

```
Operating  
hours  
00100 h
```

#### Operating hours counter

The complete running time of the measuring gas pump is displayed in operating hours.

#### SUB-MENU Memory reset

```
Memory  
reset<hPa>
```

## SUB-MENU

## Pitot fact

```

Pitot fact:
 1.00
Air Press:
1013 mbr

```

**Pitot tube factor**

If, for example, the gas velocity in a chimney is to be measured using a Pitot tube the Pitot tube factor must be input. If the Pitot tube factor is not input the gas velocity is not calculated ie only "----" is shown.

(Factor between 0.00 to 1.50 is possible).

The Pitot tube factor is engraved in the Pitot tube or printed in the enclosed data sheet.

Confirm via <Enter>. The cursor jumps to the line for inputting the current air pressure. The preset air pressure must be adapted to local conditions. The air pressure is generally only given in mbar. The data is confirmed via <Parameters>.

You then jump back to the Service menu.

(Measuring the air pressure, refer to "Technical information" in the maintenance manual).

The Pitot tube factor and air pressure are saved after the instrument is switched off.

Factory settings:	Pitot tube factor	1.00
	Air pressure	1013 mbar

## SUB-MENU

## Analog Outputs

```

AnalogOut:
1:FT
2:%CO2
3:%O2

```

**Analogue outputs**

This menu point is only active when the analysis box, available as an accessory, is connected to the handheld instrument via the RS232 interface.

Determining which parameter outputs will be at which analogue output. Procedure to allocate the measured values to the analogue outputs is the same as the indication order.

You jump to the 2nd window of the allocation analogue outputs by pressing <Parameters>.

Maximum 6 analogue outputs possible.

The following messages could appear during the self-test phase:

Self-test:  
fault  
Service is  
required!

Cause: Internal instrument error.  
Result: The instrument is not ready for operation and remains in the self-test phase and further measurements are not possible.  
Remedy: Service is required.

Self-test:  
20.4 °C AT  
Accu:0000  
Time=19DT?

Cause: The instrument is outside its operating temperature.  
Result: The instrument is not functional and remains in the self-test phase.  
Remedy: Ambient temperature must be above +4°C.

Self-test:  
20.4 °C AT  
Accu:0000  
Time=19FM?

Cause: The **testo 339** is connected. The gas path is either clogged or interrupted.  
Result: The pump flow sinks to an insufficient value.  
Remedy: Check probe, filter and gas paths.

NO-Cell  
is not  
switched  
on

Please use  
the <E>  
key to  
switch on

Cause: - The power to the rechargeable battery in the instrument has fallen below the permitted level or  
- there is a fault in the NO measuring switch.  
Result: The NO measuring cell is inactive.  
Remedy: Confirm with <E> and charge the rechargeable battery (at least 2 hours). If the display does not change to the calibration message within 10 seconds after pressing the Enter key this means that there is a fault which must be repaired by authorised service personnel.

Measurem.  
NO is not  
possible  
for 2 hrs

Self-test:  
20.4 °C AT  
Accu:0  
Time=19Ud?

Cause: Insufficient power to the measuring instrument (empty battery).  
Result: If the battery voltage drops any further (below 6.6V) there is automatic switch-off.  
Remedy: Charge the battery or connect the mains unit.

Self-test:  
11.1 °C AT  
Accu:0  
Time=19Te?

Cause: There is no temperature probe connected to the measuring box or the probe connected is defect.  
Result: The measuring instrument does not complete the self-test and starts going through the self-test again from the beginning.  
Remedy: Plug in the temperature probe or check the functions.



During later measurements the following error messages may appear:

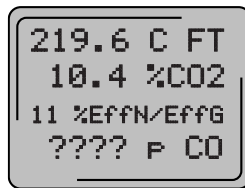

Cause: Cell defect/the primary quantity in the calculated measured values is missing.  
 Result: Measured values cannot be shown.  
 Remedy: Change the cell.

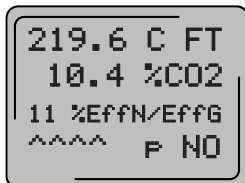

Cause: Measured value higher than the stored shut-off limit.  
 Result: Measurement was interrupted.  
 Remedy: Remove the probe from the flue gas pipe and rinse the measuring cells with fresh air. Only continue with the measurement if it is absolutely necessary.  
**Caution is recommended as the measuring cell could be destroyed.**

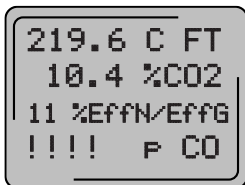

Cause: Measured value limit of the CO cell has been exceeded.  
 Result: Cell must be rinsed with fresh air.  
 Remedy: If a fresh air pump is built-in or there is a manually started gas pump (probe in fresh air) the cell is rinsed with fresh air. The fresh air pump rinses the CO cell until a CO concentration which is 30% of the set switch-off limit is measured. The fresh air rinse is stopped and the CO cell is again connected to the gas path.

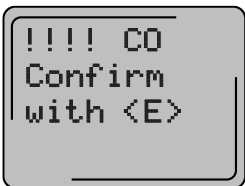

Cause: Measured value limit of the CO cell has been exceeded (CO is not displayed in the selected menu diagram).  
 Result: See above.  
 Remedy: See above.

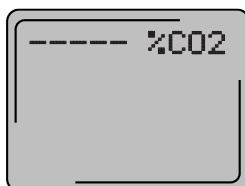

Cause: Oxygen content in flue gas > 20.0% ie there is no CO<sub>2</sub> present or the O<sub>2</sub> cell is defect.  
 Result: CO<sub>2</sub> value cannot be displayed.  
 Remedy: Check the O<sub>2</sub> display.

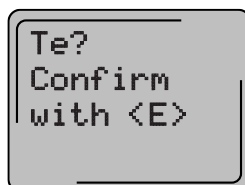

Cause: The memory is full.  
 Result: Data can no longer be saved.  
 Remedy: Erase the existing data content or data sets.

low batt  
recharge  
Confirm  
with <E>

The following error messages write over the existing display content. The error message must be acknowledged by pressing <Enter>. If the cause of the error message is not eliminated the error message appears every 3 minutes.

Low PUMP  
capacity  
Confirm  
with <E>

Cause: Insufficient power to the measuring instrument (battery is empty).  
Result: If the battery voltage drops any further (under 6.6V) there is an automatic switch-off.

Remedy: Charge the battery or connect the mains unit.

Memory  
full  
Confirm  
with <E>

Cause: **testo 339** is connected. The gas path is clogged or interrupted.  
Result: The pump flow rate drops to insufficient values.  
Remedy: Check the gas path.

Instrument  
ambt. temp  
Confirm  
with <E>

Cause: The memory is full.  
Result: Data can no longer be saved.  
Remedy: Erase the existing data content or data sets.

Over-  
writing  
is not  
possible

Cause: During operation the ambient temperature changes to values which are not permitted.

Result: This error message is shown.  
Remedy: Adapt to the ambient temperature.

Plug in  
service  
plug

Cause: You have tried to overwrite the measured values of a customer number or name. This is not possible.

Result: An error message appears.

Remedy: First delete the measured values, then save the measurement again.

Remove the  
service  
plug

Cause: Recalibration has been triggered.

Result: The instrument prepares an O<sub>2</sub> calibration and notices that the calibration plug is not plugged in.

Remedy: Plug in the calibration plug in the temperature probe input of the measuring box at the start of the calibration.

Rinse  
before  
switching  
off

Cause: Recalibration has been successfully carried out.

Result: The instrument changes to the measurement mode and the calibration plug prevents the measuring process.

Remedy: Remove the calibration plug.

Start  
rinsing  
with <E>

#### The following error message can appear when switching off

Cause: The instrument was switched off with <I/O>. The gas concentration in the measuring instrument exceeds the limits allowed.

Result: The instrument does not switch off.

Remedy: Expose the flue gas probe to fresh air, start the pump by pressing <Enter>. Once the gas concentration goes below the limits allowed (O<sub>2</sub> > 20.0%, remaining cells < 50 ppm) the instrument switches itself off.

Rinsing  
O<sub>2</sub>  
SO<sub>2</sub>

The following error messages can occur in connection with the gas preparation unit. They cannot be deleted. These error messages disappear when the error has been eliminated in **testo 339** or **testo 339** is no longer connected.

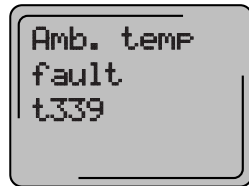

**Cause:** The ambient temperatures (+5 to +40°C) specified for **testo 339** have been exceeded or have not been achieved.  
**Result :** **testo 339** switches to the error message mode and checks the ambient temperatures until they correspond again to standard values. LED 3 lights up.  
**Remedy:** Adjust the ambient temperatures to the operation values.

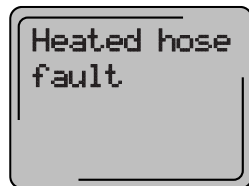

**Cause:** A probe breakage (probe defect) is detected in the temperature sensor in the gas sampling hose.  
**Result:** Further operation with the gas sampling hose is no longer possible. The instrument switches over to the error mode. The instrument is not operational. LED 4 lights up.  
**Remedy :** Replace the gas sampling hose and return for repair.



**Cause:** A defect has occurred in the gas sampling hose or in the power supply to the gas sampling hose.  
**Result :** The gas sampling hose has not heated up in spite of the power from the gas preparation unit being on. The instrument switches to the error message mode. LED 5 lights up.  
**Remedy:** Replace the gas sampling hose and return for repair.

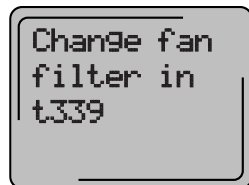

**Cause:** The cooling unit is not functioning properly because the ventilator filter is clogged. There is a build-up of heat in the instrument since the heat cannot be removed.  
**Result :** The instrument switches to the error message mode. LED 7 lights up.  
**Remedy:** Change both ventilator filters.

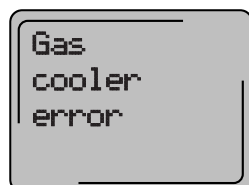

**Cause:** The gas cooling unit has not reached the specified temperatures on account of high humidity or flow levels (refer to specifications in **testo 339** Technical data)  
**Result :** Proper functioning cannot be guaranteed. The instrument switches to the fault message mode. LED 8 lights up.  
**Remedy:** Check whether the maximum permissible flow or dew-point has been exceeded at the flue gas inlet. If this is not the case the instrument must be sent for repair to an authorised service point.

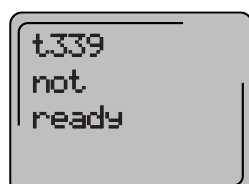

**Cause:** You tried to start the **testo 339** pump. The gas sampling hose and the cooling unit are not to the required temperature, the corresponding LEDs light up and flash.  
**Result :** Proper functioning cannot yet be guaranteed. The instrument first finishes the switch-on phase. The green LED 2 "Ready for operation" is not yet illuminated.  
**Remedy:** Wait until the switch-on phase is over.

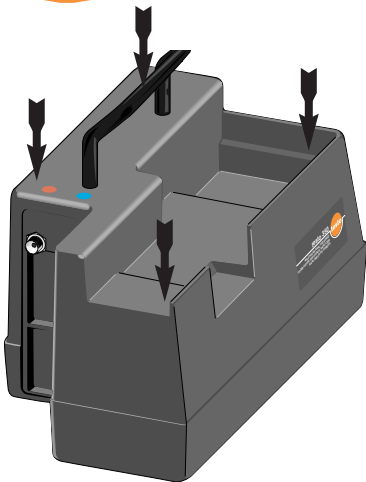

Using upgrading modules you can extend the measuring instrument by one parameter at a time.



**Before taking the module out of the packaging eliminate any static by contact with a water pipe or similar. Avoid unnecessary contact with the electronics (board) in the module.**

Check the module for any damage.

The NO module is connected to a 9V battery to maintain measuring accuracy. Check whether the cable connection is intact. The battery should only be removed just before mounting. Installation must take place within 1 hour. The battery cable remains on the module. You just have to push the insulation over the contacts.

### Remove the flue gas probe and the mains unit plug

Unscrew the 4 screws at the top of the housing and remove the lid.

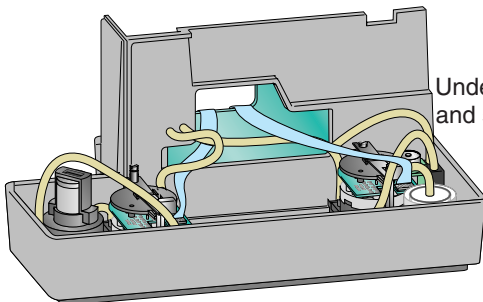

Under the storage area for the handheld instrument you will find the modules and space for the upgrading modules.

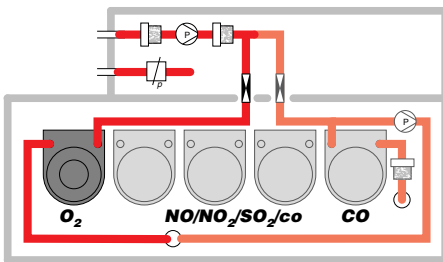

The O<sub>2</sub> module which is usually built-in has its fixed place on the left side and there is a fixed place on the right side for the upgradeable CO module. These two places should not be used for other modules.

The 3 places between the O<sub>2</sub> and the CO module are available for the NO, NO<sub>2</sub> and SO<sub>2</sub> modules but the allocation is not fixed.

Upgrading takes place from left to right ie you choose the first free place from the O<sub>2</sub> module.

CO T <sub>1</sub>	CO T <sub>2</sub>	CO T <sub>3</sub>	NO	NO <sub>2</sub>	SO <sub>2</sub>
X			X	X	X
CO W <sub>0</sub>	t 339				

### 7.1 Upgrading NO<sub>2</sub>, NO, SO<sub>2</sub> modules

In the upgrading set you will find the assembled module, a bent pipe and a connecting cable. The NO module is connected to a 9V battery as described above. Please separate the connection to the battery just before installation.

Pull out the hose marked opposite with □ from its position.

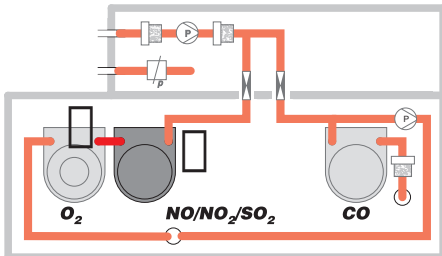

Position the upgrading module in its place and screw it in (be careful not to screw too tightly). The module is not dismantled for this procedure.

Plug the bent pipe □ to the nipple which has become free and that of the upgrading module. Now plug the pipe □ to the free nipple of the upgrading module. Check if the pipes are positioned properly.

Thread the connecting lead through the opening in the housing separation and board. On the board there are free connection sockets under the opening. You can plug in the connecting lead to a free socket.

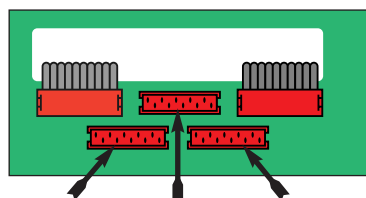
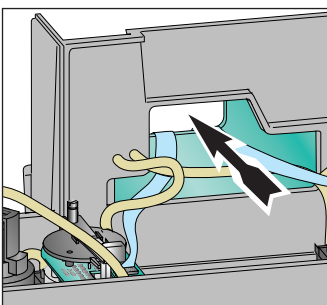

More in Chapter "Release"

## 7 Upgrading modules

### 7.2 Upgrading the CO module

CO T <sub>1</sub>	CO T <sub>2</sub>	CO T <sub>3</sub>	NO	NO <sub>2</sub>	SO <sub>2</sub>
	X		X		X
CO 1/6	1339				

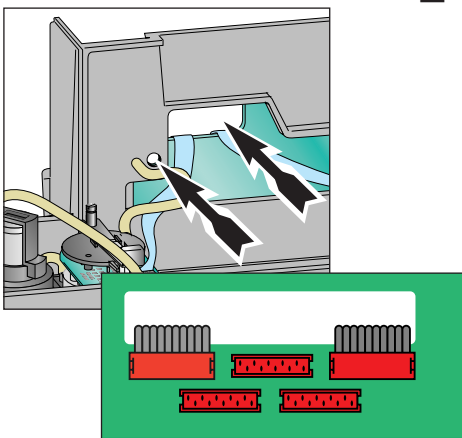
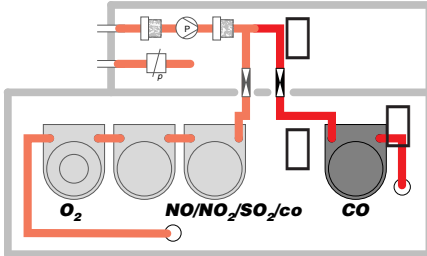

In addition to the upgrading of the NO<sub>2</sub>, NO, SO<sub>2</sub> modules you have the option of upgrading the CO module. When the CO module is being upgraded by the user the fresh air rinse is not available. However, if fresh air rinsing is required please send the instrument to our service department.

The delivery includes the CO module, the connecting cable and 2 hoses. One hose is supplied with a capillary.

The housing is opened as described on the previous page.

Position the module in its designated space and screw it in (be careful not to screw too tightly). The module remains assembled.

Plug the hose  with the capillary to the gas inlet of the module. Thread the pipe through the free hole in the housing separation and the board.

Behind the second filter there are two branches by the pipes. One has a cover cap . Pull off this cap and connect the pipe which has just been installed.

The second pipe is laid from the gas output of the module  to the CO gas outlet of the measuring box .

Ensure that all of the pipes are positioned correctly.

Thread the connecting lead through the opening in the housing separation and board. On the board there are free connection sockets below the opening. Plug the connecting lead into one of the free sockets.

### 7.3 Upgrading a second CO module

Prerequisite: integrated CO rinse

Combination possibilities when installing two CO modules:

- **CO type 1** (0 to 10 000 ppm CO, H<sub>2</sub> compensated) with **CO type 3** (0 to 40 000 ppm CO)  
The CO type 1 module must be in the CO position

- **CO type 2** (0 to 20 000 ppm CO) with **CO type 3** (0 to 40 000 ppm CO)  
The CO type 2 module must be in the CO position

The upgrading of the modules in the CO position  is carried out as described in Chapter 7.2. The second CO module (CO type 3) is upgraded in the same way as all the other gas modules (See Chapter 7.1).

### 7.4 Enabling the upgraded module

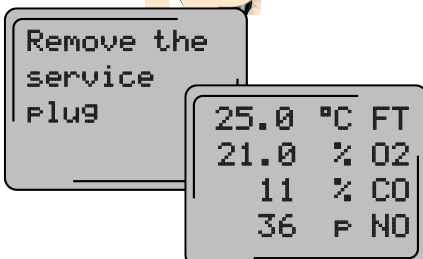

Once the measuring box has been expanded by the upgrading module place the top part of the housing on the lower part and screw the two parts together (do not tighten the screws too much).

Plug the calibration plug to the socket of the flue gas probe.

Attach the handheld instrument to the measuring box and switch on.

The measuring instrument checks the measuring module assembly of the measuring box, registers the upgraded module and takes over the enabling of the module.

Upon completion of this process you are required to remove the calibration plug. The instrument then automatically jumps to the self-test. You can now operate **testo 350**. The new parameter and the selection list of the indication order is integrated automatically to the respective display window.

Now change your chosen indication order to indicate the new parameter in the measurement menu (refer to the Chapter on Indication order).



## testo 350

### Temperature measurement:

Measuring range: -40 to +1200°C  
Accuracy: ±0.5°C (0 to +100°C)  
±0.5% of mv (from +100°C)

### Draught/pressure measurement:

Measuring range: ± 50 hPa (mbar)  
Resolution: 0.01 hPa (mbar)

### O<sub>2</sub> measurement:

Measuring range: 0 to 21 vol %  
Accuracy: ±0.2 vol %  
Measuring method: Electrochemical meas. cell  
Response time  $t_{90}$ : Approx. 20 seconds

### CO<sub>2</sub> calculation:

Display range: 0 to CO<sub>2</sub>max  
Calculation: Digital calculation from O<sub>2</sub>

### CO measurement (without H<sub>2</sub> compensation):

Measuring range: 0 to 20000 ppm  
Accuracy: ±20 ppm (to 400 ppm)  
±5% of mv (to 2000 ppm)  
±10% mv (to 20000 ppm)  
Response time  $t_{90}$ : Approx. 40 seconds

Measuring range: 0 to 40000 ppm  
Accuracy: ±50 ppm (0 to 1000 ppm)  
±5% of mv (1000 to 10000 ppm)  
±10% of mv (>10000 ppm)  
Response time  $t_{90}$ : Approx. 40 seconds

### CO measurement (with H<sub>2</sub> compensation):

Measuring range: 0 to 10000 ppm  
Accuracy: ±20 ppm (to 400 ppm)  
±5% of mv (to 2000 ppm)  
±10% of m.v. (to 10000 ppm)  
Response time  $t_{90}$ : Approx. 40 seconds

### NO measurement:

Measuring range: 0 to 3000 ppm  
Accuracy: ±5 ppm (to 100 ppm)  
±5% of mv (to 2000 ppm)  
±10% of mv (to 3000 ppm)  
Measuring method: Electrochemical meas. cell  
Response time  $t_{90}$ : ca. 20 seconds

### NO<sub>2</sub> measurement:

Measuring range: 0 to 500 ppm  
Accuracy: ± 10 ppm (to 200 ppm)  
± 5 % of mv (> 200 ppm)  
Measuring method: Electrochemical meas. cell  
Response time  $t_{90}$ : Approx. 40 seconds

### SO<sub>2</sub> measurement:

Measuring range: 0 to 5000 ppm  
Accuracy: ±20 ppm (to 400 ppm)  
±5% of mv (to 3000 ppm)  
±10% of mv (to 5000 ppm)  
Measuring method: Electrochemical meas. cell  
Response time  $t_{90}$ : Approx. 40 seconds

### Humidity measurement:

Meas. range, humidity: 0 to 100%RH  
Meas. temperature: -20.0 to +140°C

### Velocity measurement:

Meas. range, velocity: 1.0 to 10 (30) m/s  
Application, temperature: 0 to +500°C

### Differential pressure measurement:

Measuring range: 100 hPa (mbar)  
Accuracy: ±0.1 hPa (mbar)  
(0 to 20 hPa (mbar))  
± 0.5% of mv  
(20 to 100 hPa (mbar))  
Resolution: 0.01 hPa (mbar)  
Measuring range: 10 hPa (mbar)  
Accuracy: ± 0.03 hPa (mbar)  
Resolution: 0.01 hPa (mbar)

### Dimensions:

Hand-held instrument: 197 x 55 x 45mm  
Analyser: 294 x 163 x 158mm

### Weight:

Hand-held instrument: Approx. 0.24kg  
Analyser: Approx. 2.8kg

### General data:

Housing: Plastic (ABS)  
(instrument and analyser)  
Max. operating temp: +4 to +40°C  
Max. storage and  
transport temperature: -20 to +50°C  
Power supply: Mains unit or integr. batt. block

## Sample gas preparation unit

### Functional principle:

Peltier cooler

### Power supply:

Instrument: 90 to 260V, 47 to 63 Hz  
Hose: 110V or 230V

### Max. dust load:

20 g/m<sup>3</sup> dust in flue gas

### Max. humidity load:

+60°C dew point temperature at inlet

### Operating temperature:

+5 to +40°C

### Max. flow:

1.8 l/min

### Storage and transport temperature:

-20 to +50°C

### Housing:

Aluminium, 180 x 170 x 300mm with handle

### Hose:

Ø 30mm temperature-controlled +150°C to +170°C

### Gewicht:

Instrument: Approx. 4.8 kg  
Hose: Approx. 1.2 kg / 2.2m long

## Flue gas probes

### Length:

300–700mm

### $t_{max}$ :

500 / 1000°C

### Weight:

Flue gas probe 0600.8520	0.9 kg
Flue gas probe 0600.8720	0.8 kg
Flue gas probe 0600.9522	0.4 kg

## Printer

### Type of printer:

infrared controlled thermal printer,  
adjustable contrast

### Printing capacity:

Approx. 300 printouts per roll

### Reception radius:

Max. m

### Dimensions:

186 x 91 x 61mm

### Weight:

0.43 kg (incl. batteries)

### Operating temperature:

0 to +50°C

### Storage temperature:

-40 to +60°C

### Power supply:

4 AA, 1.5V or NC rechargeable batteries

## Warranty:

### Measuring instrument:

(expendable parts exempt,  
such as measuring cells, filter, pump,  
rechargeable batteries)

24 months

### Probes:

12 months

### Hose, can be heated:



6 months

### O<sub>2</sub> cell:



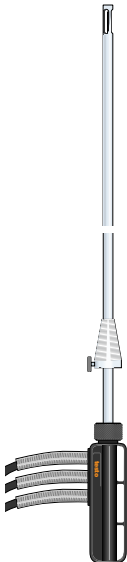
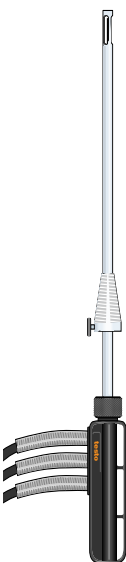
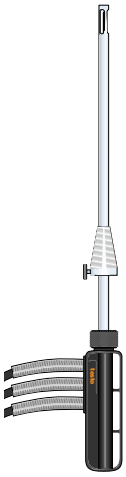

18 months

### CO, NO, NO<sub>2</sub>, SO<sub>2</sub> module:

6 months

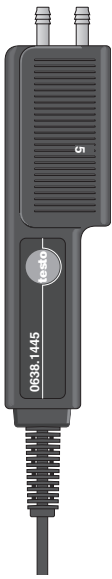
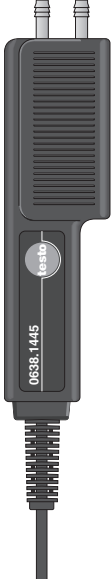
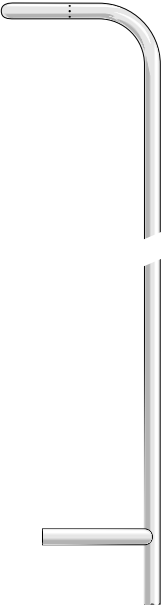
Application	Comfort probe for flue gas measurement	Comfort probe for flue gas measurement	Compact probe for flue gas measurement <small>(not used with the gas sampling unit)</small>	Monitoring ambient humidity	Monitoring of waste gas humidity to 140°C
in connection with:	Analysis box and basic or Comfort hand-held instr.	Analysis box and basic or Comfort hand-held instr.	Analysis box and basic or Comfort hand-held instr.	Comfort hand-held instrument	Comfort hand-held instr.
Measuring range	T <sub>max</sub> = +1000°C	T <sub>max</sub> = +1000°C	T <sub>max</sub> = +500°C	0 to 100%RH (probe tip) -20 to +70°C	0 to 100%RH -20 to +140°C
Temperature sensor	NiCr-Ni	NiCr-Ni	NiCr-Ni	NTC	NTC
Immersion depth	715mm	395mm	300mm	245mm	300mm
Ø probe hose	8mm	8mm	8mm	21mm	12mm
Gas outlets	2	2	2	–	–
Cable length	2.20m	2.20m	2.20m	1.50m	1.50m
Probe	<p>Flue gas probe with standard gas sampling hose* <b>0600.8731</b></p> <p>Flue gas probe with high-quality gas sampling hose* <b>0699.3049/1</b></p> 	<p>Flue gas probe with standard gas sampling hose* <b>0600.8732</b></p> <p>Flue gas probe with high-quality gas sampling hose* <b>0699.3049/2</b></p> 	<p>Compact probe with standard gas sampling hose* <b>0600.9522</b></p> <p>Compact probe with high-quality gas sampling hose* <b>0699.3049/3</b></p> 	<p>Humidity / temperature probe <b>0636.9768</b></p> 	<p>Humidity / temperature probe <b>0636.2168</b> with stainless steel cap</p> 
The correct gas sampling hose for your application	Measurement of °C, O <sub>2</sub> , CO, NO	Standard gas sampling hose with condensate trap, L 2.20m			
	Short-term measurement of NO <sub>x</sub> , SO <sub>x</sub>	High-quality gas sampling hose with separator and condensate trap, L 2.20m			
	Long-term meas. of °C, O <sub>2</sub> , CO, NO, NO <sub>x</sub> , SO <sub>x</sub>	Heated gas sampling hose in connection with gas sampling unit, L 2.20 or 4m (refer to Accessories)			

\* For the heated gas sampling hose refer to the Ordering data for the sample preparation unit

Measurement of pressure and differential pressure		Measurement of the flue gas velocity in combination with pressure probe			Separate measurement of combustion air temperature
Comfort hand-held instrument		Comfort hand-held instrument			Basic or Comfort handheld instrument
100 mbar	10 mbar	$T_{max} = 350^{\circ}\text{C}$ 1.0 to 30m/s	$T_{max} = 350^{\circ}\text{C}$ 1.0 to 30m/s	$T_{max} = 500^{\circ}\text{C}$ 1.0 to 30m/s	$T_{max} = 100^{\circ}\text{C}$
-	-	-	-	-	NTC
-	-	500mm	350mm	300mm	300mm with cone
Pitot tube connection 5mm	Pitot tube connection 5mm	7mm	7mm	4mm	5mm
-	-	-	-	-	-
1.50m	1.50m	-	-	-	1.50m
Pressure probe 0638.1545	Pressure probe 0638.1445	Pitot tube, brass 0635.2045	Pitot tube, brass 0635.2145	Pitot tube, stainless steel 0635.2245	Air probe 0610.9713
					



The following equations are used to calculate the listed values:

CO<sub>2</sub> value:  $CO_2 = CO_{2max} \times \frac{CO_2 - CO_{2set}}{O_2 - CO_{2set}}$

CO<sub>2max</sub>: Fuel-specific max. CO<sub>2</sub> value  
 CO<sub>2set</sub>: Oxygen content in the air  
 O<sub>2</sub>: Measured oxygen content

Flue gas loss:  $EffG = 100 - \left[ \frac{CO}{CO_{2max}} \right] + \left[ \frac{X \times (2488 + 2.1 \times FT - 4.2 \times AT)}{CO_2} \right] + \left[ \frac{K1 \times CO}{CO_2} \right]$

$EffN = 100 - \left[ \frac{CO}{CO_{2max}} \right] + \left[ \frac{X \times (210 + 2.1 \times FT - 4.2 \times AT)}{CO_2} \right] + \left[ \frac{K1 \times CO}{CO_2} \right]$

$X = MH_2O + 9 \times H$

FT: Flue gas temperature  
 AT: Ambient temperature

K<sub>gr</sub>, K<sub>net</sub>, K<sub>1</sub>, Hydrogen content of fuel H, Moisture content of fuel MH<sub>2</sub>O, Q<sub>gr</sub>, Q<sub>net</sub>, ref are all fuel-specific factors.

$\lambda = \left[ \frac{CO_2}{CO_{2max}} - 1 \right] \times 100$

$uCO = CO \text{ (ppm)} \times \frac{CO_2}{CO_{2max}}$

$rat = \frac{CO \text{ (ppm)}}{CO_{2max}}$

**Conversion of ppm to mg/m<sup>3</sup> referred to the O<sub>2</sub> reference value  
(freely selectable according to fuel)**

$$\text{CO (mg/m}^3\text{)} \quad \text{CO} = \frac{O_{2 \text{ set}} - O_{2 \text{ ref}}}{(O_{2 \text{ set}} - O_2)} \times \text{CO (ppm)} \times 1.25$$

O<sub>2 set</sub> : Oxygen content in the air  
O<sub>2</sub>: Measured oxygen content

Fitted with NO + NO<sub>2</sub>:      NO<sub>x</sub> (mg/m<sup>3</sup>)      NO<sub>x</sub> =  $\frac{O_{2 \text{ set}} - O_{2 \text{ ref}}}{(O_{2 \text{ set}} - O_2)} \times \left[ \text{NO (ppm)} + \text{NO}_2 \text{ (ppm)} \right] \times 2.05$

Fitted only with NO:      NO<sub>x</sub> (mg/m<sup>3</sup>)      NO<sub>x</sub> =  $\frac{O_{2 \text{ set}} - O_{2 \text{ ref}}}{(O_{2 \text{ set}} - O_2)} \times \text{NO (ppm)} \times \left[ 1 + \frac{\text{NO}_2\text{-add}}{100} \right] \times 2.05$

O<sub>2 set</sub> : Oxygen content in the air  
O<sub>2</sub>: Measured oxygen content

$$\text{SO}_2 \text{ (mg/m}^3\text{)} \quad \text{SO}_2 = \frac{O_{2 \text{ set}} - O_{2 \text{ ref}}}{(O_{2 \text{ set}} - O_2)} \times \text{SO}_2 \text{ (ppm)} \times 2.93$$

**Conversion of ppm to g/GJ**

$$\text{CO (g/GJ)} \quad \text{CO} = \frac{O_{2 \text{ set}}}{O_{2 \text{ set}} - O_{2 \text{ meas.}}} \times \text{CO (ppm)} \times \text{FBr} \times 1.25$$

$$\text{NO}_x \text{ (g/GJ)} \quad \text{NO}_x = \frac{O_{2 \text{ set}}}{O_{2 \text{ set}} - O_{2 \text{ meas.}}} \times \text{NO}_x \text{ (ppm)} \times \text{FBr} \times 2.05$$

$$\text{SO}_2 \text{ (g/GJ)} \quad \text{SO}_2 = \frac{O_{2 \text{ set}}}{O_{2 \text{ set}} - O_{2 \text{ meas.}}} \times \text{SO}_2 \text{ (ppm)} \times \text{FBr} \times 2.93$$

**Conversion of (ppm) to mg / kWh**

$$\text{CO (g/GJ)} \quad \text{CO} = \frac{O_{2 \text{ set}}}{O_{2 \text{ set}} - O_{2 \text{ meas.}}} \times \text{CO (ppm)} \times \text{FBr} \times 3.6 \times 1.25$$

$$\text{NO}_x \text{ (g/GJ)} \quad \text{NO}_x = \frac{O_{2 \text{ set}}}{O_{2 \text{ set}} - O_{2 \text{ meas.}}} \times \text{NO}_x \text{ (ppm)} \times \text{FBr} \times 3.6 \times 2.05$$

$$\text{SO}_2 \text{ (g/GJ)} \quad \text{SO}_2 = \frac{O_{2 \text{ set}}}{O_{2 \text{ set}} - O_{2 \text{ meas.}}} \times \text{SO}_2 \text{ (ppm)} \times \text{FBr} \times 3.6 \times 2.93$$

FBr See "Fuel selection"

The following equations are used to calculate the listed values:

CO<sub>2</sub> value:  $CO_2 = \frac{\quad}{21}$

CO<sub>2max</sub>: Fuel-specific  
max. CO<sub>2</sub> value

21: Oxygen content in the air

O<sub>2</sub>: Measured oxygen content

Flue gas loss:  $qA = \left[ (FT-AT) \left[ \frac{A2}{\quad} + B \right] \right] - K_k$

In combustion plants the qA value can fall into the negative range.  
The furnace efficiency eta then reaches values >100%.

FT: Flue gas temperature

AT: Ambient temperature

A2/B Fuel-specific factors

K<sub>k</sub> Condensation factor

Factors

21: Oxygen content in the air

O<sub>2</sub>: Measured oxygen content  
(rounded off to one digit after the point)

Furnace  
efficiency

$\text{Eta} = 100 - qA$

If the fuel-specific factors A2 and B are zero the Siegertsche Formula is applied using factor f:

$qA = f \times \frac{(FT - AT)}{\quad}$

Excess air  
value λ:

$\lambda = \frac{\quad}{\quad}$

CO<sub>2max</sub>: Fuel-specific  
maximum CO<sub>2</sub> value

CO<sub>2</sub>: Calculated CO<sub>2</sub> value

f: Fuel-specific  
factor

CO<sub>undiluted</sub> :  $CO_{undiluted} = CO \times \lambda$

CO: Measured CO value

λ: Excess air value

**Conversion of ppm to mg/m<sup>3</sup> referred to the O<sub>2</sub> reference value  
 (freely selectable according to fuel)**

$$\text{CO (mg/m}^3\text{)} \quad \text{CO} = \frac{21 - \text{O}_2\text{ref}}{(21 - \text{O}_2)} \times \text{CO (ppm)} \times 1.25$$

O<sub>2 set</sub> : Oxygen content in the air  
 O<sub>2</sub>: Measured oxygen content

Fitted with NO + NO<sub>2</sub>:

$$\text{NO}_x \text{ (mg/m}^3\text{)} \quad \text{NO}_x = \frac{21 - \text{O}_2\text{ref}}{(21 - \text{O}_2)} \times \left[ \text{NO (ppm)} + \text{NO}_2 \text{ (ppm)} \right] \times 2.05$$

Fitted only with NO:

$$\text{NO}_x \text{ (mg/m}^3\text{)} \quad \text{NO}_x = \frac{21 - \text{O}_2\text{ref}}{(21 - \text{O}_2)} \times \left[ \text{NO (ppm)} \times \left[ 1 + \frac{\text{NO}_2\text{-add}}{100} \right] \right] \times 2.05$$

O<sub>2 set</sub> : Oxygen content in the air  
 O<sub>2</sub>: Measured oxygen content

$$\text{SO}_2 \text{ (mg/m}^3\text{)} \quad \text{SO}_2 = \frac{21 - \text{O}_2\text{ref}}{(21 - \text{O}_2)} \times \text{SO}_2 \text{ (ppm)} \times 2.93$$

**Conversion of ppm to g/GJ**

$$\text{CO (g/GJ)} \quad \text{CO} = \frac{21}{21 - \text{O}_{2 \text{ meas.}}} \times \text{CO (ppm)} \times \text{FBr} \times 1.25$$

$$\text{NO}_x \text{ (g/GJ)} \quad \text{NO}_x = \frac{21}{21 - \text{O}_{2 \text{ meas.}}} \times \text{NO}_x \text{ (ppm)} \times \text{FBr} \times 2.05$$

$$\text{SO}_2 \text{ (g/GJ)} \quad \text{SO}_2 = \frac{21}{21 - \text{O}_{2 \text{ meas.}}} \times \text{SO}_2 \text{ (ppm)} \times \text{FBr} \times 2.93$$

**Conversion of (ppm) to mg / kWh**

$$\text{CO (g/GJ)} \quad \text{CO} = \frac{21}{12 - \text{O}_{2 \text{ meas.}}} \times \text{CO (ppm)} \times \text{FBr} \times 3.6 \times 1.25$$

$$\text{NO}_x \text{ (g/GJ)} \quad \text{NO}_x = \frac{21}{21 - \text{O}_{2 \text{ meas.}}} \times \text{NO}_x \text{ (ppm)} \times \text{FBr} \times 3,6 \times 2.05$$

$$\text{SO}_2 \text{ (g/GJ)} \quad \text{SO}_2 = \frac{21}{21 - \text{O}_{2 \text{ meas.}}} \times \text{SO}_2 \text{ (ppm)} \times \text{FBr} \times 3.6 \times 2.93$$

FBr See "Fuel selection"

***Even after the warranty time  
has run out***

*our customer service will look  
after you! Send us your  
measuring instrument with a  
brief description of the fault.  
Include your telephone number  
should we need to contact you.*

Dear Customer

Thank you for your confidence in Testo which you have shown by buying this measuring instrument. You have made the right choice in choosing a quality product.

The warranty time is

- **24 months for display instruments**
- **12 months for probes**

Warranty services do not extend the warranty time.

The warranty is not valid for the following:

- All working parts such as rechargeable batteries, measuring cells, filters, measuring elements etc.
- Fragile parts
- Damage caused by improper use
- Damage caused by non-adherence to the Instruction Manual
- Measuring instruments which have been opened after purchase provided this is not described in the Instruction Manual for maintenance purposes.
- Instruments whose serial number has been changed, damaged or removed.

We will repair any faults **free of charge** if

- it can be proven that they are manufacturing faults,
- the faults are reported immediately
- the faults are reported to us within the warranty time.

You will be charged for any additional repairs, adjustments or similar carried out by us and not under warranty. There is also a charge for transport and packaging.

Other claims, in particular those for damage occurring outside the instrument, will not be accepted unless legally binding.

Description	Order no.
<b>Accessories / Printer</b>	
<b>Infrared printer</b> to printout of the measured values (thermal printer), incl. 4 round cell batteries, 1 roll of thermal paper.....	<b>0554.0545</b>
<b>Comfort software</b> .....	<b>On request</b>
<b>Basic software</b> , read out memory, create an ASCII file.....	<b>0554.0112</b>
<b>Battery charging unit for infrared printer</b> , incl. 4 NC-rechargeable batteries .....	<b>0554.0110</b>
<b>Additional thermal paper</b> (6 rolls) .....	<b>0554.0115</b>
<b>Attachable bags</b> , (50 off) to hold the measurement log on the boiler.....	<b>0554.0116</b>
<b>Connection cable</b> , hand-held instr. → PC or analyser box → gas preparation unit, L 1.80m .....	<b>0409.0154</b>
<b>Analogue outputs</b> with 6 channels in an external housing, connection via RS232 interface and cable (0554.0154) .....	<b>0554.3614</b>
<b>Software</b>	
<b>Read-out software for further processing</b> of the measured data with current analysis programs (eg Lotus, MS Excel) .....	<b>0554.0112</b>
<b>Comfort software "Light"</b> .....	<b>0554.0182</b>
<b>Comfort software "Professional"</b> .....	<b>0554.0258</b>
<b>Cases</b>	
<b>Service case</b> , leather, for hand-held instr., analyser, flue gas probe (short) and tools .....	<b>0516.0130</b>
<b>Carrying strap</b> for the analyser .....	<b>0516.0060</b>
<b>Transport case</b> , aluminium edges, for gas preparation unit, hand-held instrument, analyser box, heated hose, probe and accessories .....	<b>0516.0139</b>
<b>Transport case</b> , aluminium edges, for analyser, complete <u>or</u> gas preparation unit, complete.....	<b>0516.0350</b>
<b>Case</b> incl. carrying strap .....	<b>0516.0038</b>
<b>Gas preparation unit / Accessories</b>	
<b>Gas preparation unit testo 339</b> , incl. mains cable, 2 substitute fuses, Connection cable to the analyser <b>testo 350</b> (L 0.4m), service hose.....	<b>0563.3390</b>
<b>Gas sampling hose</b> , heated, L. 2.2m, 230V version, incl. filter insert .....	<b>0401.0390</b>
<b>Gas sampling hose, as above</b> , however as 110V version .....	<b>0401.0396</b>
<b>Gas sampling hose</b> heated, L 4m, 230V version, incl. filter insert .....	<b>0401.0395</b>
<b>Condensate container</b> for attachment to the gas preparation unit.....	<b>0554.0391</b>
<b>Spare parts pack for gas preparation unit:</b>	
1 pump head for hose pump, 5 ventilator filters, 5 fuses, incl. assembly instructions.....	<b>0554.0392</b>
<b>Hose filter insert</b> for gas sampling hose (5 pack).....	<b>0554.0393</b>
<b>Preliminary filter</b> to protect gas paths (gas preparation unit) in fresh air (dust load) .....	<b>0554.0394</b>
<b>Calibration certificates</b>	
<b>Flue gas</b>	
Standard calibration certificate, measuring points 21%O <sub>2</sub> , 100 and 1000 ppm CO, 300 ppm NO, 80 ppm NO <sub>2</sub> , 100 ppm SO <sub>2</sub> .....	<b>0520.0003</b>
Special calibration certificate, measuring points according to availability of calibration gases, parameters freely selectable .....	<b>0520.0103</b>
<b>Temperature</b>	
Standard calibration certificate, measuring points -20, 0, 60°C for immersion probes, 60, 120°C for surface probes.....	<b>0520.0001</b>
Special calibration certificate, measuring points freely selectable -40 to +1000°C (with surface probes +50 to +420°C) .....	<b>0520.0101</b>
DKD/NAMAS calibration certificates, measuring points freely selectable from -40 to +1000°C .....	<b>0520.0201</b>
<b>Pressure</b>	
Standard calibration certificate, measuring points 5, 18, 50, 80 hPa (mbar) or 1, 2, 5, 10 hPa (mbar) (depending on probe) .....	<b>0520.0005</b>
Special calibration certificate, measuring points freely selectable from 5 to 1000 hPa.....	<b>0520.0105</b>
<b>Humidity</b>	
Standard calibration certificates, measuring points 12, 76%RH at 25°C.....	<b>0520.0006</b>
Special calibration certificate, measuring points freely selectable from 5 to 95% RH and +10 to +100°C, max. dew-point 70°C .....	<b>0520.0106</b>

Description	Order No.
<b>Accessories for handheld instrument</b>	
Mains charging unit <b>testo 350</b> .....	0554.0085
Connection cable, spiral cable for connection between hand-held instrument/analyser unit .....	0409.0350
Connection cable 5m for connection between hand-held instrument/analyser unit .....	0409.0351
Connection cable 10m (as above) .....	0409.0352
Connection cable 20m, (as above) .....	0409.0353
<b>Upgrading modules</b>	
CO module 1, measuring range 0 to 10 000 ppm, H <sub>2</sub> compensated .....	0554.3503
CO module 2, measuring range 0 to 20 000 ppm .....	0554.3502
CO module 3, measuring range 0 to 40 000 ppm .....	0554.3507
NO module 4, measuring range 0 to 3 000 ppm .....	0554.3504
NO <sub>2</sub> module 5, measuring range 0 to 500 ppm .....	0554.3505
SO <sub>2</sub> module 6, measuring range 0 to 5 000 ppm (if the NO <sub>2</sub> content in the waste gas > 20 ppm please also order NO <sub>2</sub> module) .....	0554.3506
<b>Spare cell modules</b>	
O <sub>2</sub> spare cell set, .....	0390.9003
CO spare module 1, measuring range 0 to 10 000 ppm, H <sub>2</sub> compensated .....	0390.0103
CO spare module 2, measuring range 0 to 20 000 ppm .....	0390.0102
CO spare module 3, measuring range 0 to 40 000 ppm .....	0390.0107
NO spare module 4, measuring range 0 to 3 000 ppm .....	0390.0104
NO <sub>2</sub> spare module 5, measuring range 0 to 500 ppm .....	0390.0105
SO <sub>2</sub> spare module 6, measuring range 0 to 5 000 ppm (for NO <sub>2</sub> components in flue gas > 20 ppm please also order an NO <sub>2</sub> module) .....	0390.0106
Filter set for internal particle filter, (for 10 filter changes) .....	0554.0095
Spare NO filter for the CO cell .....	0554.0113
<b>Flue gas probes</b>	
Flue gas probe* T <sub>max</sub> = +1000°C, immersion depth 715mm, (incl. 2.20m conn. hose and cable) .....	0600.8731
Flue gas probe as above, but with high quality hose material and condensate trap for short-term NO <sub>2</sub> , SO <sub>2</sub> measurements .....	0699.3049/1
Flue gas probe* T <sub>max</sub> = +1000°C, immersion probe 300mm, (incl. 2.20m conn. hose and cable) .....	0600.8732
Flue gas probe as above, but with high-quality hose material and condensate trap for short-term NO <sub>2</sub> , SO <sub>2</sub> measurements .....	0699.3049/2
Compact probe* T <sub>max</sub> = +500°C, immersion probe 300mm, (incl. 2.20m connection hose and cable) not for use with gas preparation option .....	0600.9522
Compact probe as above, but with high quality hose material and condensate trap for short-term NO <sub>2</sub> , SO <sub>2</sub> measurements .....	0699.3049/3
Spare filter material, for flue gas probe filter set .....	0554.3371
<b>Probes</b>	
Air probe, NTC for separate measurement of the combustion air temperature, T <sub>max</sub> = +80°C, L 60mm in total .....	0610.3691
Air probe, T <sub>max</sub> to +100°C, L 300mm, Ø 5mm with screw cone .....	0610.9791
Pressure probe <sup>§</sup> , 10 mbar .....	0638.1445
Pressure probe <sup>§</sup> , 100 mbar .....	0638.1545
Magnetic holder for pressure probes .....	0554.0225
Silicon hose for pressure probes, L 5m .....	0554.0440
Pitot tube <sup>§</sup> , for flue gas velocity, Chromed brass, Ø 7mm, L 500mm, max. temperature 350°C .....	0635.2045
Pitot tube <sup>§</sup> , for flue gas velocity, Chromed brass, Ø 7mm, L 350mm, max. temperature 350°C .....	0635.2145
Pitot tube <sup>§</sup> , for flue gas velocity, Stainless steel, Ø 4mm, L 300mm, max. temperature 500°C .....	0635.2245
Air probe for ambient humidity <sup>§</sup> , 0 to 100%RH, T <sub>max</sub> = +70°C .....	0636.9768
High temperature probe for flue gas humidity with stainless steel sintered cap <sup>§</sup> , 0 to 100%RH, T <sub>max</sub> = +140°C .....	0636.2168
Teflon sintered filter for high temperature filter 0636.2167, T <sub>max</sub> = +180°C .....	0554.0656
Control and calibration set, (12%RH, 76%RH) .....	0554.0660
Control and storage humidity, (33%RH) .....	0554.0636

§ only with Comfort hand-held instrument 0560.3520  
\* not suitable for NO<sub>2</sub>, SO<sub>2</sub> measurements

Main menu	Sub-menu	Input/Information masks	Page	
Send....	Print		30	
Fuel	Heat.Oil EL Natural gas Liquid gas Coke, Wood ...		30	
Enter...	O2ref./CO2M	Heating oil EL CO2M=15.5T O2ref=04 D	31	
	Factors	Fuel.1 Kg Kn K1	Fuel 1 FB=0.2545 31	
	HT Temp.	Inout HT Temp 000 °C	31	
	Soot/Oil deriv.	Soot1=2 Soot2=1 Soot3=2 Soot v->2	Inout Oil deriv. - 31	
Service...	Instr. stat.	22.4 °C DT 11.6V Ud 1.0l/min	32	
	Meas. var.	Temp. = °C Gas = PPM Drght = hPa Veloc = m/s	32	
	Switch-off	CO :02500 NO :020000 NO2:0350 SO2:03500	33	
	Indic. ord.	01.FT 02.AT 03.%O2 04.NO	34	
	NO2add	NO2 add: 05.%	35	
	Calibrate	O2-Cal.	O2-Sensor- Typ=0 Start <E> Cancel<B>	Calibrate: ADC-Value: O2: -3241 Time= 24 35
		Recalibr.	CO -Cell NO -Cell NO2 -Cell SO2 -Cell	Recalibrate CO -Cell 890 pCO 873 pCO 36
	Print-Text	Line 1: Line 2:	38	
	Date/Time	Time= 15:02:00 Date= 07:07:94	38	
	Operat. hours counter	Operating hours 000100 h	38	
	Memory	Memory	Memory Memory reset <hPa>	38 21
Memory		Memory Memory reset <hPa>	23	
Pitot tube factors	Pitot tube factor 1.00 Air Press. 1013 mbr	39		
AnalogOut.	01.FT 02.AT 03.%O 04.NO	39		



**Special functions key**

Input Select	Scan time miss 00:00
Input Select	Average Name:





**testo 350**

Flue gas analyser

# Maintenance manual

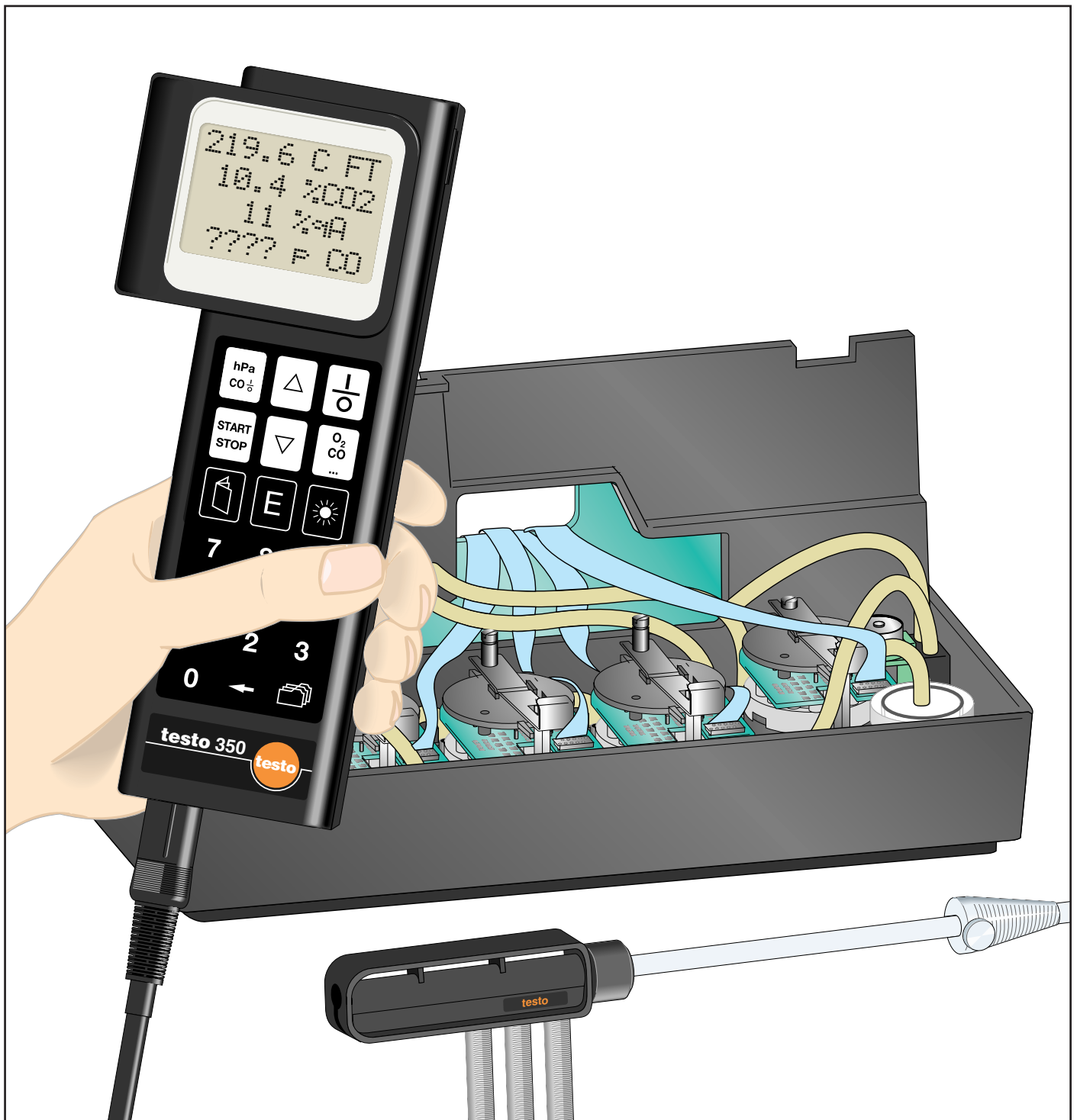



- 1 **Maintenance of the measuring instrument**
- 1.1 Opening the housing .....3
- 1.2 Changing the fine filter in the measuring box .....4
- 1.3 Changing the measuring cells .....4
- 1.3 Changing O<sub>2</sub> measuring cells .....4
- 1.3 Calibrating the O<sub>2</sub> measuring cell .....5
- 1.3 Changing the CO, NO, NO<sub>2</sub>, SO<sub>2</sub> measuring cells .....6
- 1.4 Changing the rechargeable battery .....7
  
- 2 **Maintenance of the flue gas probe**
- 2.1 Cleaning the flue gas probe .....8
- 2.2 Changing the thermocouple .....9
- 2.3 Changing the filter in the condensate trap .....10
- 2.4 Flue gas probe for short-term measurements of NO<sub>2</sub>/SO<sub>2</sub> .....11
  
- 3 **Equipping the measuring case** .....12
  
- 4 **Technical information**
- 4.1 Data on cross-sensitivity .....14
- 4.2 Long-term measurements .....15
- 4.3 NO<sub>2</sub>/SO<sub>2</sub> measurements .....16
- 4.4 Overpressure/Pressure surges .....16
- 4.2 Entering the air pressure .....17
  
- 5 **Ordering data** .....18

# 1 Maintenance of the measuring instrument

## 1.1 Opening the housing

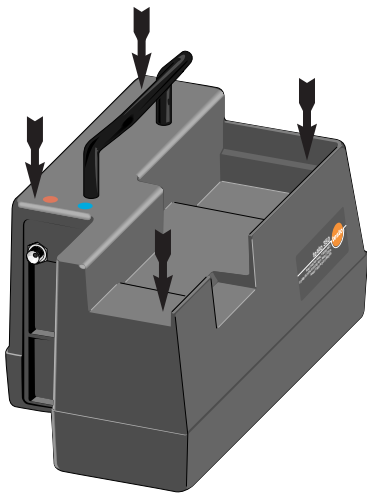

For some of the operations described below it is necessary to open the housing. In order to avoid having to describe this before every operation the procedure is described here once.



**Before carrying out the operations in the instrument eliminate any static by contact with a water pipe or similar. Avoid unnecessary contact with the electronics (board) in the module.**

Remove the flue gas probe and the mains unit plug.

Unscrew the 4 screws at the top of the housing and remove the top of the housing.

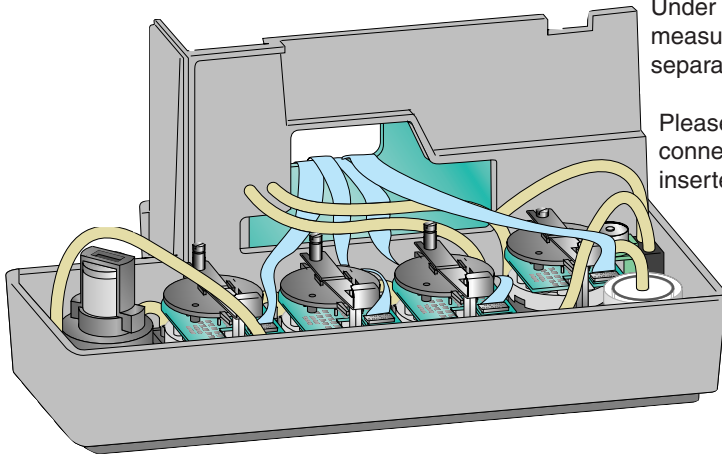

Under the storage area for the handheld instrument you will find the measuring cells and opposite the electronics (behind the housing separation).

Please take care when carrying out installation that the pipe connections do not become loose and that they are properly inserted so that leakage in the system does not hinder operation.

### View of the open measuring box

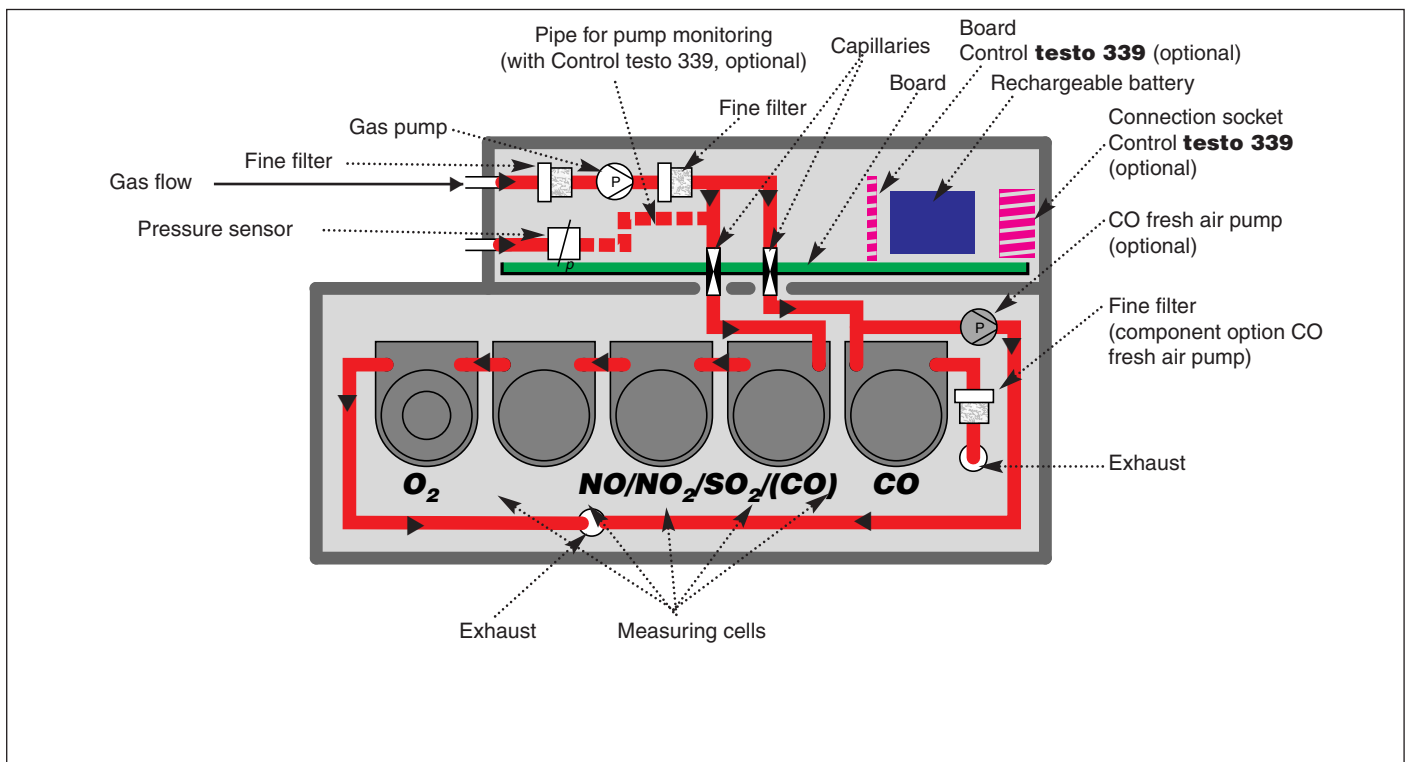

Before closing check again the hose and cable connections.

Make sure that there are no cables or hoses caught when the top part is closed down and screwed.

**Do not screw too tightly in order to avoid damage to the housing.**

# 1 Maintenance of the measuring instrument

## 1.2 Changing the fine filter in the measuring box

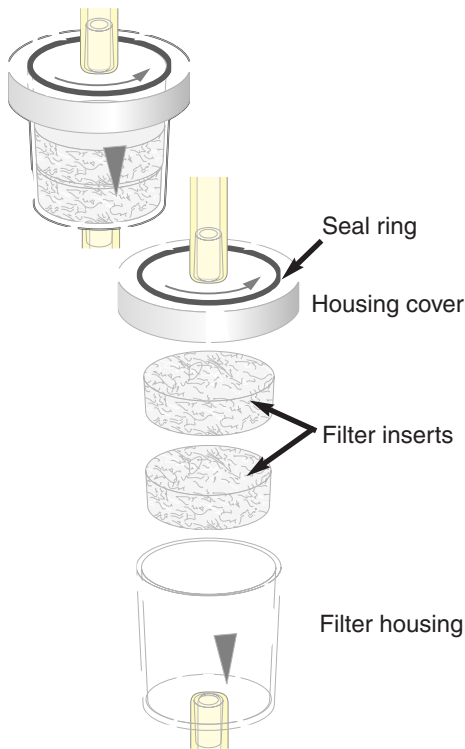

The fine filter in the analyser box has a limited lifetime. The filter must be changed from time to time in order to guarantee problem-free operation.

Open the housing in the analyser box (See page 3)

The electronics and the fine filter are located under the handle. A fine filter is located on the side of the measuring cells in instruments equipped with a CO measuring cell (with fresh air rinse) from the factory.

The fine filter consists of a transparent housing with a screw cap. There are two filter inserts in the housing.

To change the filter unscrew the housing cover in the direction of the arrow. The pipes do not need to be pulled from the filter housing.

Remove the dirty filter (with a tweezers) and insert 2 new filters. Always use 2 filter inserts and do not press them together more than is required.

Make sure when closing the cover that the sealing ring is sitting properly and that it is not damaged. Close the cover until the limit stop.

## 1.3 Changing the measuring cells

Measuring cells have a limited lifetime. Used measuring cells must be changed in order to guarantee problem-free operation. The steps involved in changing the measuring cells are described below.

### Changing O<sub>2</sub> measuring cells, 0390.9003

Due to logistics the spare parts set may contain an O<sub>2</sub> measuring cell as well as type 0 measuring cell or also type 1. Both measuring cells are the same with the exception of the electric connections and the mechanical dimensions.

The O<sub>2</sub> measuring cell is located on the left side of the instrument.

- Pull out the connection cable from the plug.
- Unscrew the holder screws.
- Remove the holder and the used measuring cell.
- Insert the new measuring cell in the notch.
- Put on the holder **supplied** (suitable for the measuring cell) and screw down **carefully**.
- Connect the connection cable in accordance with the connection instructions on the plug.

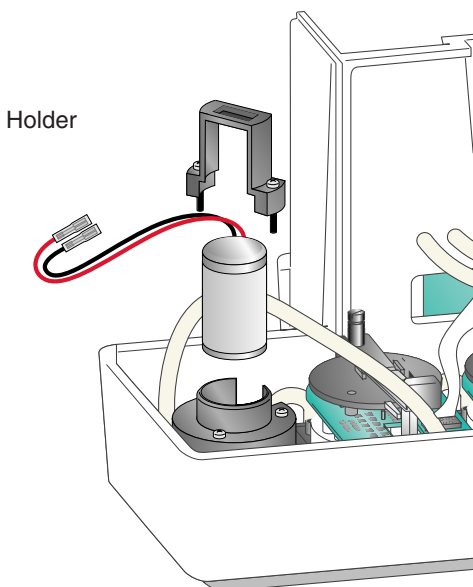

#### Type 0

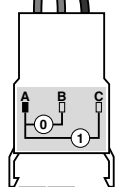

Brown Green

#### Type 1

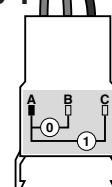

Black Red

A cell calibration must be carried out after the measuring cells have been changed.

When disposing of the used measuring cell you should treat it like commercial batteries or send it to Testo.



# 1 Maintenance of the measuring instrument

## 1.3 Changing the measuring cells Calibrating the O<sub>2</sub> measuring cell

The calibration data is subject to write protection. In order to cancel the write protection the service plug  supplied with the measuring box must be plugged in in place of the flue gas probe plug for the duration of the calibration.

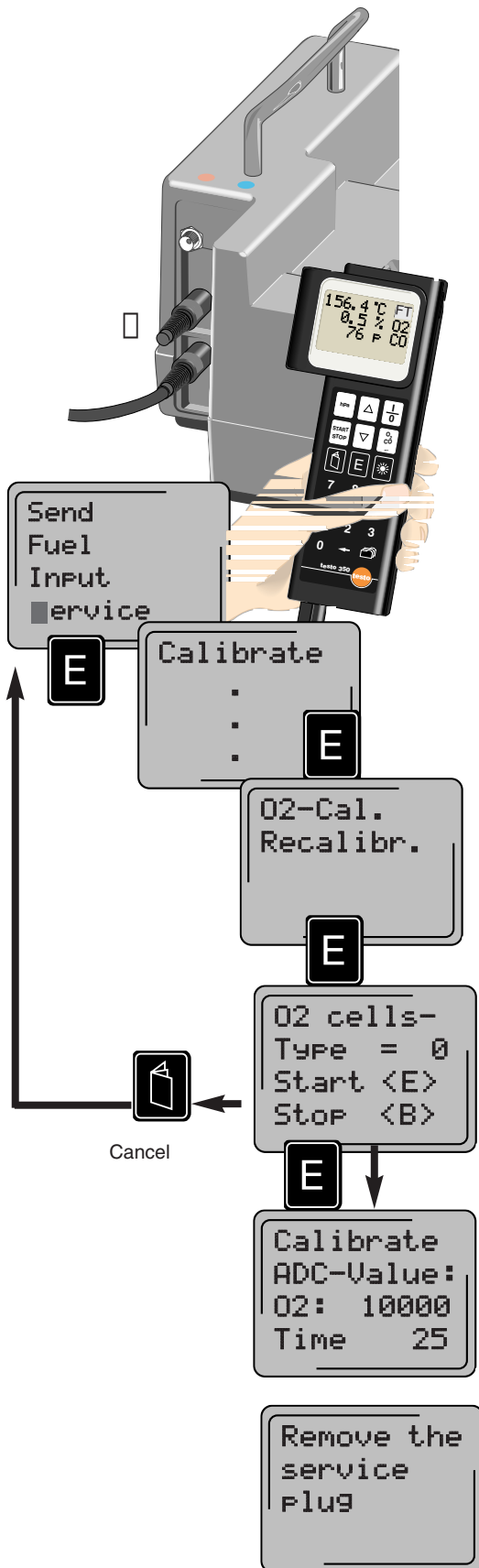
**A plug-in power pack is recommended in order to guarantee power supply.**



Select the submenu “Gas calibration of an O<sub>2</sub> measuring cell” (Service menu  Calibration  O<sub>2</sub> calibration).

You are asked about the O<sub>2</sub> sensor type used (See rating plate of the measuring cell).

Set the sensor type of the measuring cell used (See Inputting values). Plug in the service plug and confirm the entry via <Enter>. The automatic O<sub>2</sub> calibration is started at the same time. You can cancel this procedure by pressing <Scroll>.

Calibration and the saving of the measuring cells data (ADC values) is automatic. The measuring cell type 0 requires approx. 25 minutes for this procedure while type 1 requires approx. 15 minutes.

Remove the service plug if the instrument asks you to do so. The instrument jumps to the zeroising phase and is then ready to operate.



# 1 Maintenance of the measuring instrument

## 1.3 Changing the measuring cells

### Changing the CO, NO, NO<sub>2</sub>, SO<sub>2</sub> measuring cells

0390.0102, 0390.0103, 0390.0104, 0390.0105, 0390.0106, 0390.0107,

An electronics board is mounted on the measuring cells. The measuring cell and the board are not separated during installation. The mounted board contains the calibration data of the measuring cell. The measuring cell is therefore changed without gas calibration. Send back your used measuring cells to Testo. You will receive a credit note for the electronics board. The measuring cell will be disposed of by Testo.

The measuring cells are marked for better identification by a coloured ring on the cell housing. The marking is attached to the bottom of the board so that the measuring cells can be identified when built in.

The marking is as follows:

Measuring cell (Name)	Coloured ring
CO (Carbon monoxide)	.....red
SO <sub>2</sub> (Sulphur dioxide)	.....green
NO (Nitrogen oxide)	.....orange
NO <sub>2</sub> (Nitrogen dioxide)	.....black

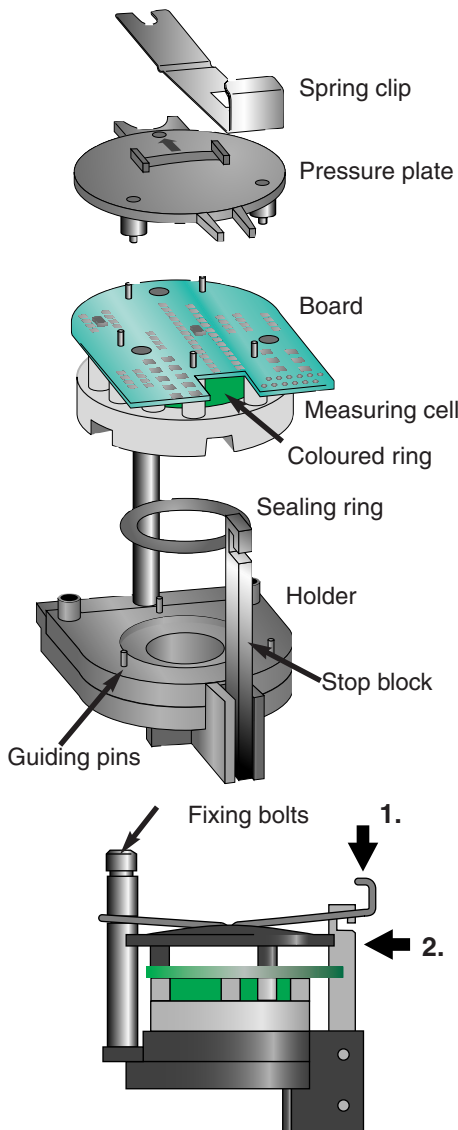

**⚠ Before taking the module out of its packaging eliminate any static by contact with a water pipe or similar. Avoid unnecessary contact with the electronics (board) of the measuring cell.**

Check the measuring cell for any damage.

The NO module is connected to a 9V battery to maintain measuring accuracy. Check whether the cable connection is intact. The battery should only be removed just before mounting. Installation must take place within 1 hour. The battery cable remains on the measuring cell board. You just have to push the insulation over the contacts. The power for the NO cell is supplied from the measuring box. **Therefore it is important to remove the battery (danger of running down).**

Open the analyser box (see page 3).

The measuring cells are located under the storage area for the handheld instrument. The O<sub>2</sub> module which is usually built-in has its fixed place on the left side and there is a fixed place on the right side for the CO measuring cell. The three spaces in between are for the NO, NO<sub>2</sub>, SO<sub>2</sub> measuring cells or for a second CO cell.

Orientate yourself using the coloured markings and open the module required (1. Press down the spring clip, 2. Push back the stop block, release the spring clip and pull off).

Remove the pressure plate from the measuring cell.

Remove the measuring cell with the board from the holder. Pull the plug from the board.

Replace the old sealing ring with the new one. Make sure that the sealing ring is not damaged and sits properly in the holder.

Plug the cable onto the socket of the new board. Make sure that the plug is positioned properly (the cable points to the back). The plug has a small pin on the side which clamps into the hole near the socket.

Carefully plug the measuring cell and the board into the holder (guide pins).

Attach the pressure plate to the board, the arrow on the pressure plate points to the round fixing bolts (towards the inside of the housing).

Insert the spring clips to the bottom groove of the fixing bolt (in the upper groove of a CO cell), then press down and lock into place.

Make sure when closing the housing that no cables or pipes are caught.

When you switch on the measurement system again it is immediately ready for operation.

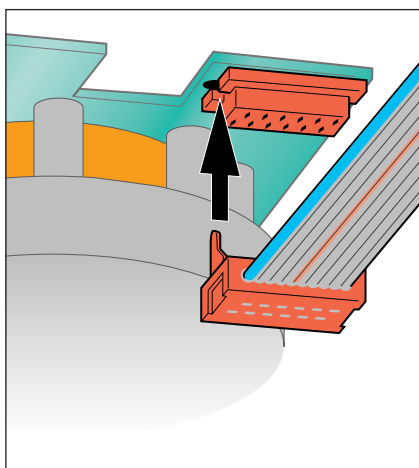

# 1 Maintenance of the measuring instrument

## 1.4 Changing the rechargeable battery

Rechargeable batteries are expendable parts whose lifetime depends on the handling it receives. If you have charged the battery and you still get the message "Charging" discharge the rechargeable battery fully by letting the pump run until the instrument switches off. Charge the battery again. If the message "Charging" (after more than 6 hours of charging) is still shown on the display there must be a charging defect. The battery should be changed. Please observe the following.



Discharge the battery until the instrument switches off. You can now recharge the battery. "Clearance" charging after only a few measurements shortens the lifetime considerably.

Do not store the instrument with discharged rechargeable batteries for long periods. Recharge the battery at least once a month.

The rechargeable battery must be changed within 1 hour so that the characteristic curve in the NO measuring cell does not sink. If there has been a drop in the voltage for a longer period an NO measurement is not possible for 2 hours after switching on.

When changing the rechargeable battery it is imperative that the mains unit is plugged out.

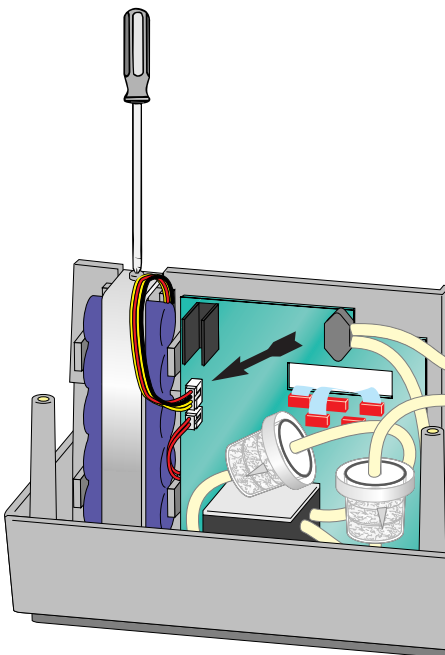

Open the analyser box housing (see page 3).

Pull out the rechargeable battery plug (⊕) from the board and unscrew the screw on the fastening clip.

Pull the clip and the rechargeable battery up out of the holder.

Now insert the new rechargeable battery in the holder and the battery clip in the slot provided in the floor of the housing. Screw in the screw again.

Plug the battery plug into the board socket.

Close the housing.

Please dispose of used or defect rechargeable batteries at collection points, in special rubbish dumps or send it to Testo.

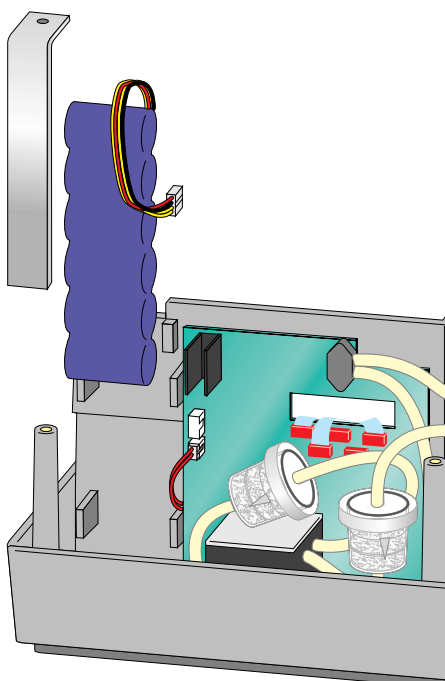



## 2 Maintenance of the flue gas probe

### 2.1 Cleaning the flue gas probe 0600.9522, 0699.3049/3

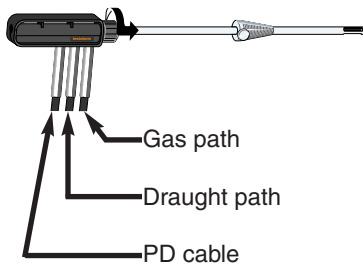

If there is a large amount of dust in the flue gas the gas path sections in front of the pipe filter can become clogged or alloyed.

Remove the special pipes:  
Unscrew and pull the outer probe at the screw connection.

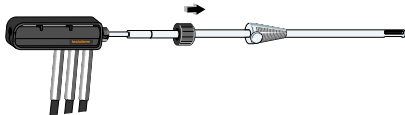

Using a fork wrench (4 mm) lever out the inner pipe at the marked wrench surface and carefully pull it out from the handle.

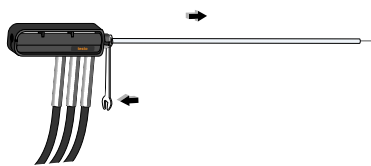

Place and move the **probe pipes** in hot water.  
Blow air through or clean with a round brush (e.g made of brass).

Rinse the gas conducting **tubes** with warm water.  
Dry by sucking in warm **clean** air preferably for several hours.

The flue gas probe is put together in the opposite order.



**Make sure that the screw connections are properly screwed and that the tubes are properly inserted and do not leak.**



## 2 Maintenance of the flue gas probe

### 2.2 Changing the thermocouple 0600.9522, 0699.3049/3

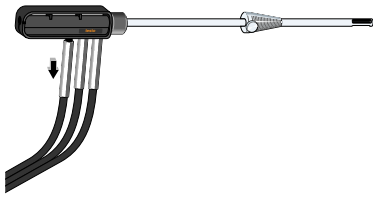

Pull out the bending protection spring from the rail at the back exit with a counter-clockwise movement and pull out the tube cable to the left.



**Pull out the thermocouple, e.g. by using a screwdriver on the wire clip. Do not pull at the thermocouple cable.**



Remove the bending protection spring over the thermocouple and take the cable out of the slit tube.

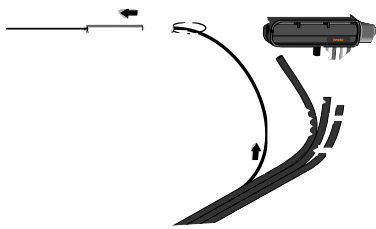

**When inserting the new thermocouple make sure that the thermocouple cable is not bent. Press the thermocouple with the wire clip into the handle.**

from the flue gas probe

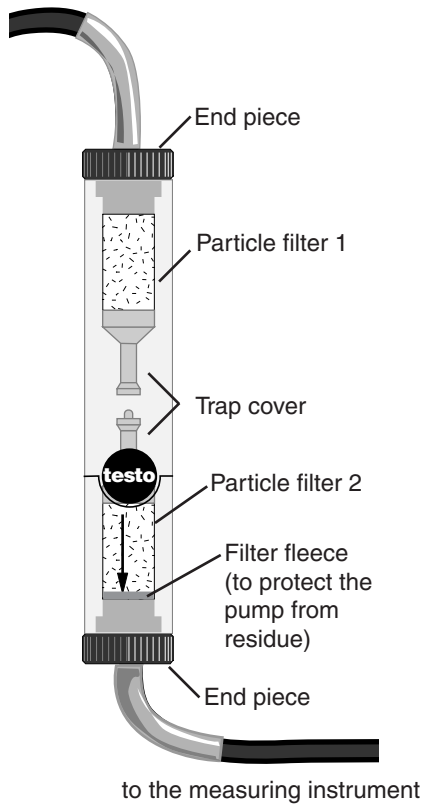

**An independent condensate trap with 2 particle filters is integrated in the connecting lead of the 0600.8731/8732/9522 flue gas probes. Particle filters 1 and 2 are equipped with filter material.**

To remove the condensate, pull off one of the end pieces and pour out the condensate.

If you see that the filter material (fibrous web) is dirty, it must be replaced. Damp/wet filter material must be dried. Remove the small filter tubes in order to replace/dry the filter material. Order replacement material for the filter with part no. 0554.3371.



**Only empty the condensate trap when the pump is switched off.**

**The construction of the condensate trap requires a certain flow direction. It is marked by arrows on the housing. If the gas flows in the opposite direction, the condensate separation will not function correctly; this may lead to instrument failure.**

**When fitting and assembling the condensate trap, take care not to damage the seals or mix-up the separating covers.**

## 2 Maintenance of the flue gas probe

### 2.4 Flue gas probe for short-term measurements of NO<sub>2</sub>/SO<sub>2</sub> 0600.8521, 0600.8721, 0600.9523

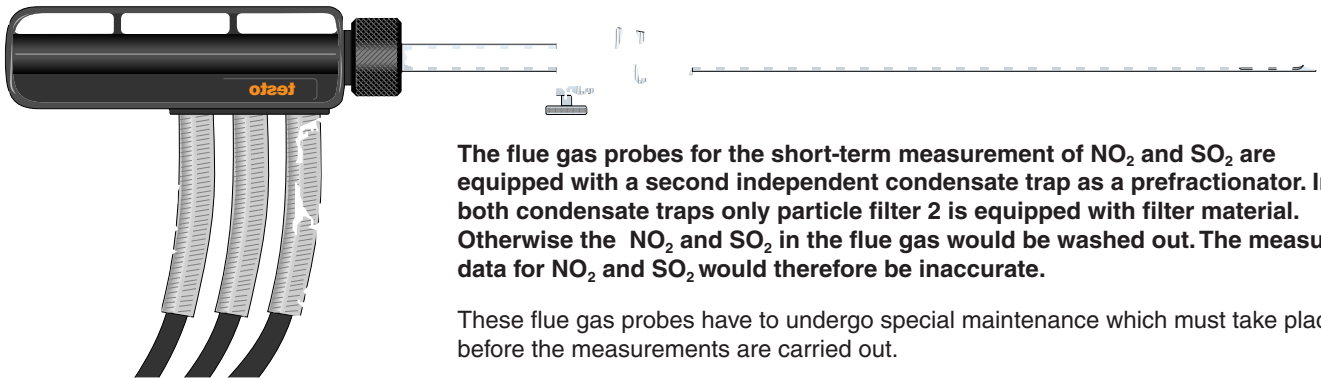

The flue gas probes for the short-term measurement of NO<sub>2</sub> and SO<sub>2</sub> are equipped with a second independent condensate trap as a prefractionator. In both condensate traps only particle filter 2 is equipped with filter material. Otherwise the NO<sub>2</sub> and SO<sub>2</sub> in the flue gas would be washed out. The measured data for NO<sub>2</sub> and SO<sub>2</sub> would therefore be inaccurate.

These flue gas probes have to undergo special maintenance which must take place before the measurements are carried out.

The probe pipe, tube, condensate trap and their filters must be dry, dust-free and clean for the measurement.

from the flue gas probe

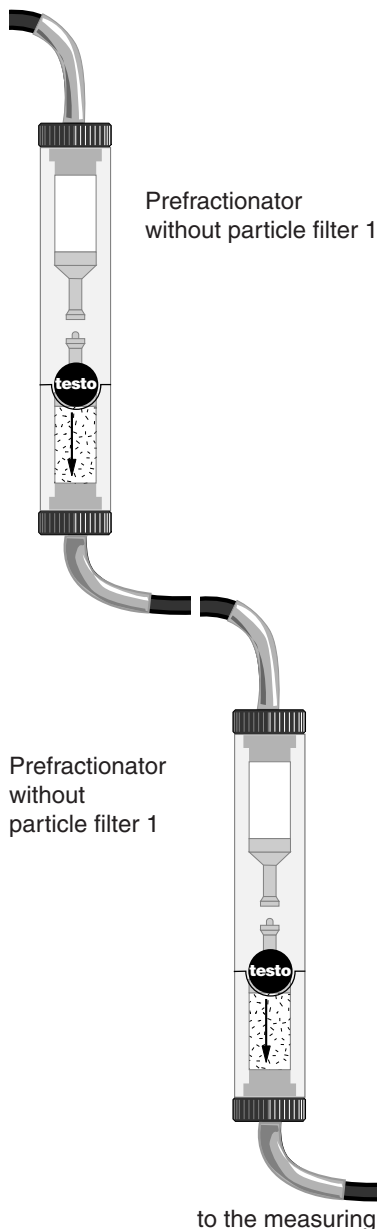

Probe pipe: Clean the probe pipe with a cloth. Dry the probe pipe by sucking in **clean** but warm air. Never blow compressed air through the pipe because deposited oil drops could lead to absorptions.

Tube: Rinse the gas conducting tube with warm water. Dry by taking in warm **clean** air (preferably for several hours). Never blow compressed air through the tube because deposited oil drops could lead to absorptions.

Condensate trap: Clean the condensate trap with a cloth. Change the dirty filter. Damp filters can be dried on the heater.

To remove the condensate pull off one of the end pieces and pour out the condensate.

If you see that the filter material (fibrous web) is dirty, it must be replaced. Damp/wet filter material must be dried. Remove the filter in order to replace/dry the filter material. Order replacement material for the filter with part no. 0554.0084.



Only empty the condensate trap when the pump is switched off.

The construction of the condensate trap requires a certain flow direction. It is marked by arrows on the housing. If the gas flows in the opposite direction, the condensate separation will not function correctly; this may lead to instrument failure.

When fitting and assembling the condensate trap, take care not to damage the seals or mix-up the separating covers.

Only particle filter 2 can be equipped with filter material.

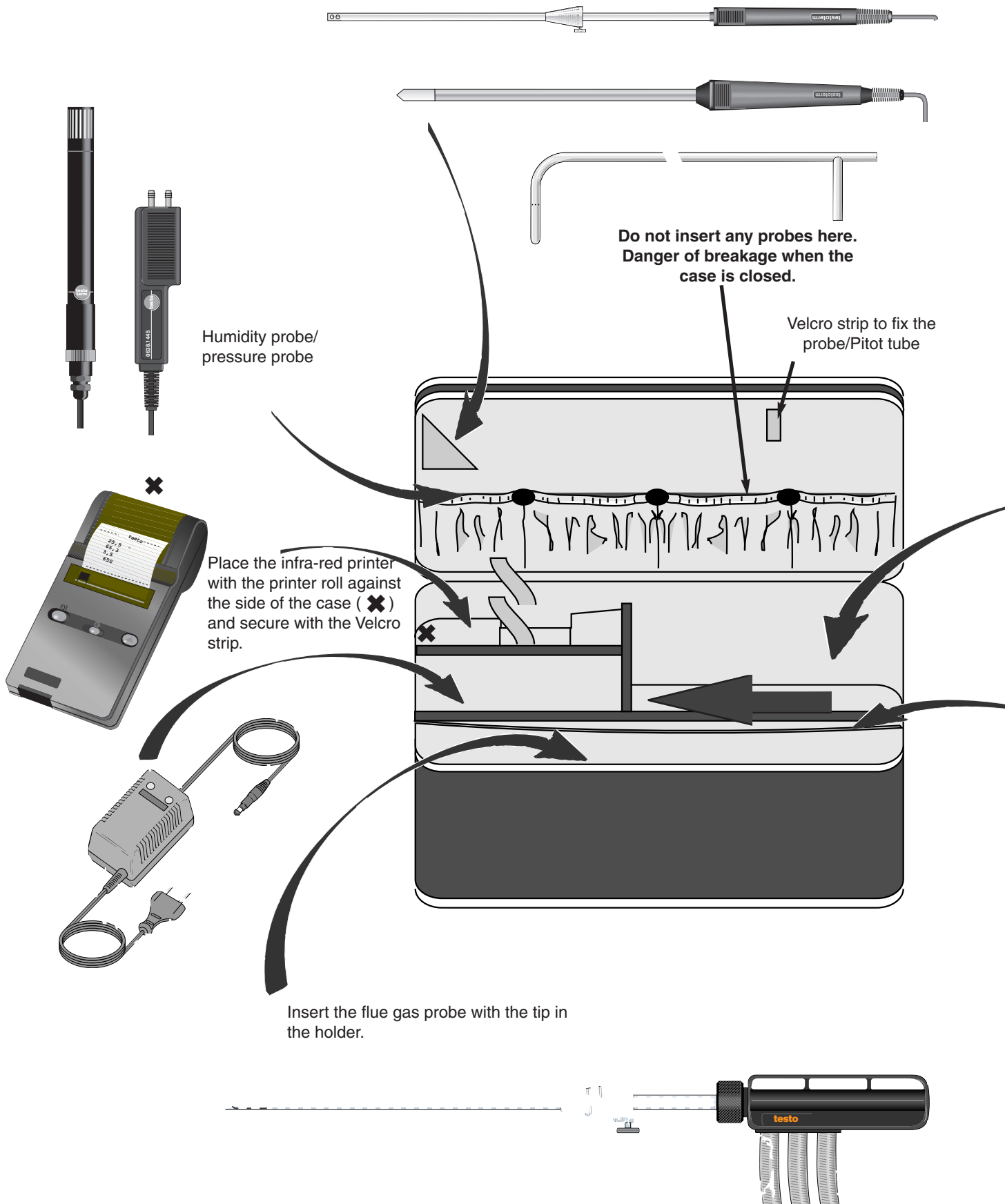

### 3 Equipping the measuring case

The bottom sections under the infrared printer and the analyser box can be removed. There you will find space for small parts such as filters, printer paper etc.

The holes in the bottom section of the analyser box are gas outlets. Ensure that these openings are free at all times to guarantee problem-free operation.

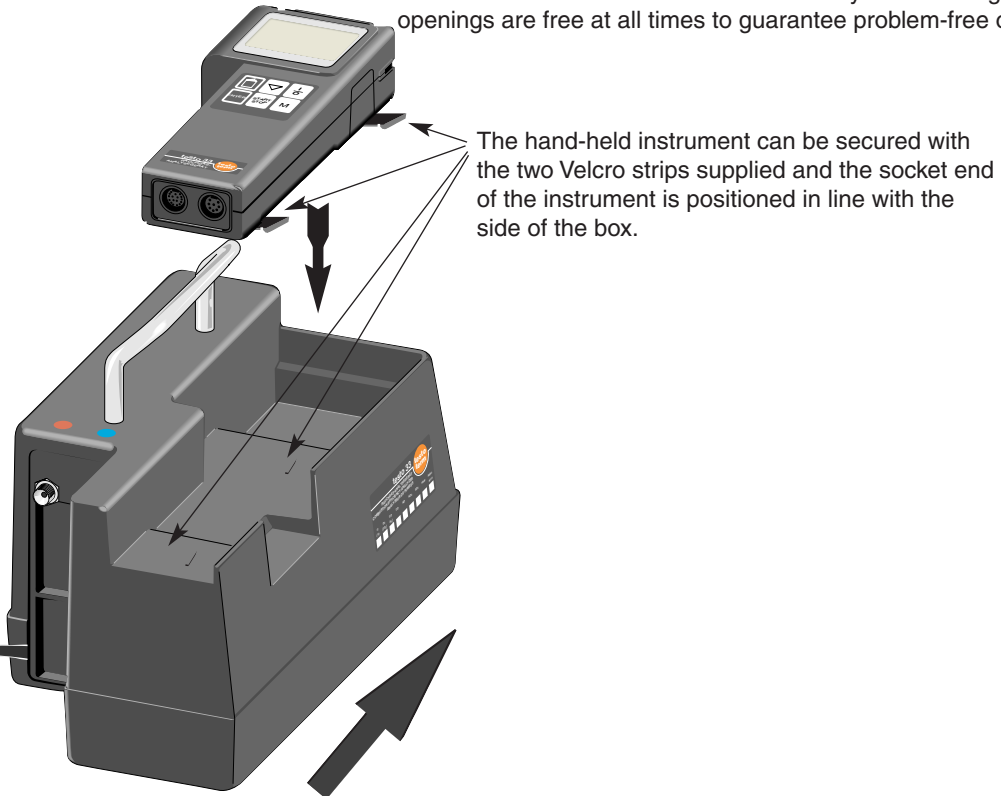

The hand-held instrument can be secured with the two Velcro strips supplied and the socket end of the instrument is positioned in line with the side of the box.

Position of the measuring box in the case:  
the connections point to the side of the case

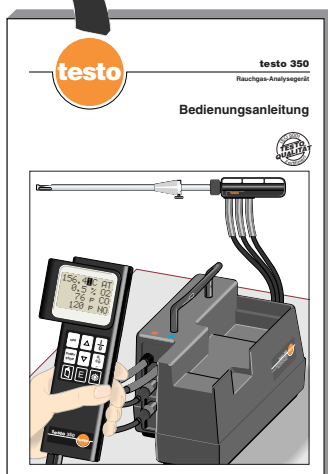

Independent of the sensor systems used analysers have so-called cross-sensitivities which can influence the measured data. The following table applies to **testo 350**:

#### Cross sensitivities in % of measured value

		Gas present									
		CO	H <sub>2</sub> S	SO <sub>2</sub>	NO	NO <sub>2</sub>	H <sub>2</sub>	CL <sub>2</sub>	HCN	HCl	C <sub>2</sub> H <sub>4</sub>
Display	COH <sub>2</sub> comp.	100	0	0	0	0	0	0	0	0	approx. 35
	CO	100	0	0	0	0	<60	0	0	0	0
	NO	0	0	0	100	0**	0	0	0	<5	0
	NO <sub>2</sub>	0	approx. -25	approx. -3	0	100	0	<90	0	0	0
	SO <sub>2</sub>	<3	0	100	0	approx. -110	approx. 3	approx. -80	approx. 30	0	approx. 50
	O <sub>2</sub>	Without cross-sensitivities									

A "-" sign means that the display value is made smaller.

There are no sensitivities in saturated hydrocarbons such as methane, ethane, propane etc.

High concentrations of corrosive gases such as HCN, HCl, fluoride etc can attack the gas paths or the cell housing.

Example:

There are 200 ppm SO<sub>2</sub> and 50 ppm HCl in the flue gas.

The SO<sub>2</sub> display would then be approx. 207 - 208 ppm due to the influence of HCl.

\* The cross-sensitivity of the SO<sub>2</sub> in relation to NO<sub>2</sub> is calculated if the NO<sub>2</sub> cell is built-in.

\*\* The cross-sensitivity of the NO cell in relation to NO<sub>2</sub> is calculated if the NO<sub>2</sub> cell is built-in.

Electronic measuring cells need fresh air phases to regenerate. This can be seen in long-term measurements which take place over longer periods e.g. 1 day. The number and duration of the required fresh air times depend on the gas concentration and the discharge duration.

**Measuring and rinsing cycle for gas preparation**

Example: Determining the measuring and rinse times

The expected gas concentrations are plotted on the x axis. If, for example, a gas concentration of 2000 ppm carbon monoxide (CO) is expected draw a vertical line at this point on the x axis. There is then an intersecting point with the measuring curve and with the rinse curve. The measuring and rinse times can be read by going from the intersecting points to the y axis.

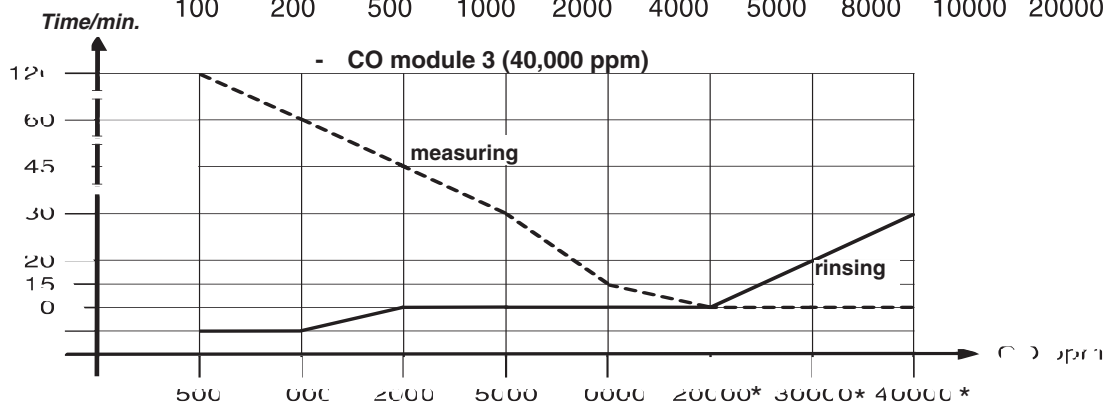
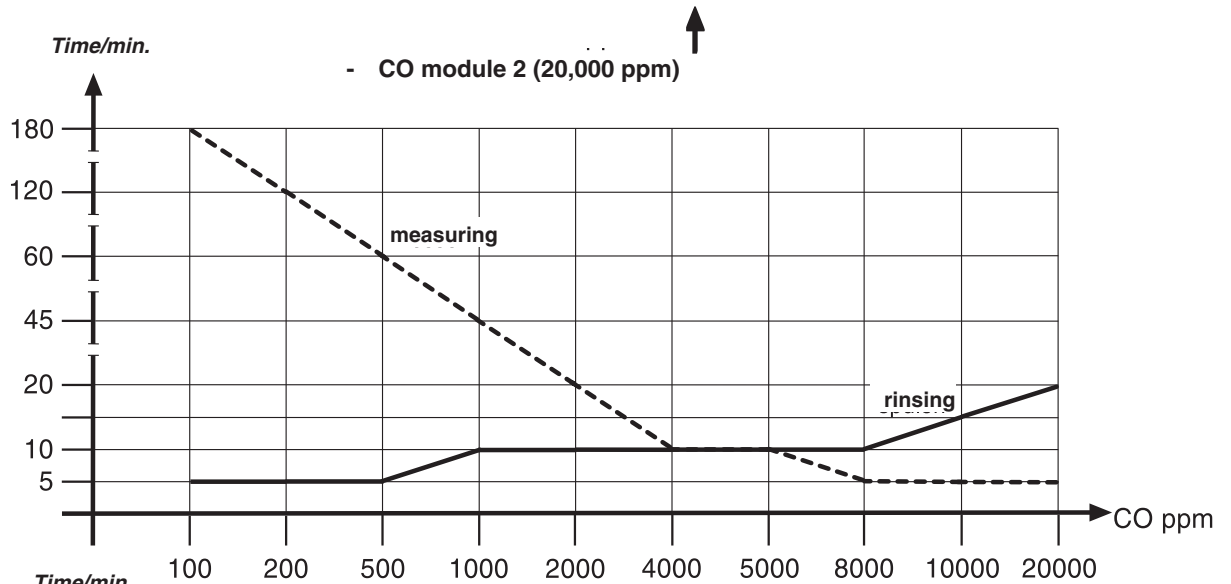
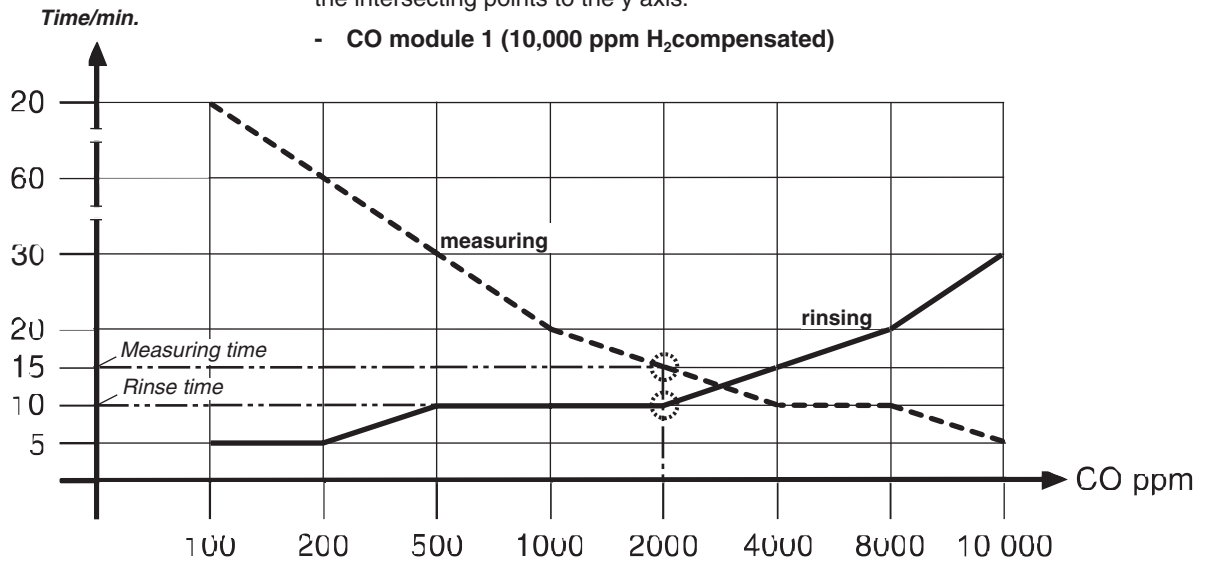

\* After measuring high concentrations rinse for 5 minutes before the next measurement. Then switch the instrument on and off 2-3 times (3x self-test).



## 4 Technical information

### 4.2 Long-term measurements Measuring and rinsing cycle for gas preparation

- NO module 4

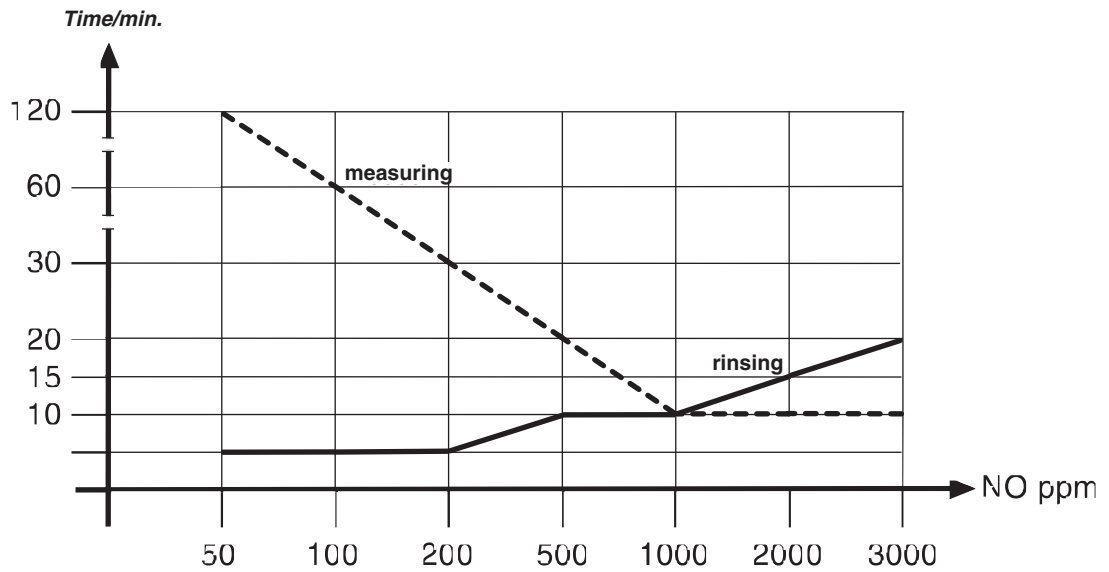

- NO<sub>2</sub> module 5

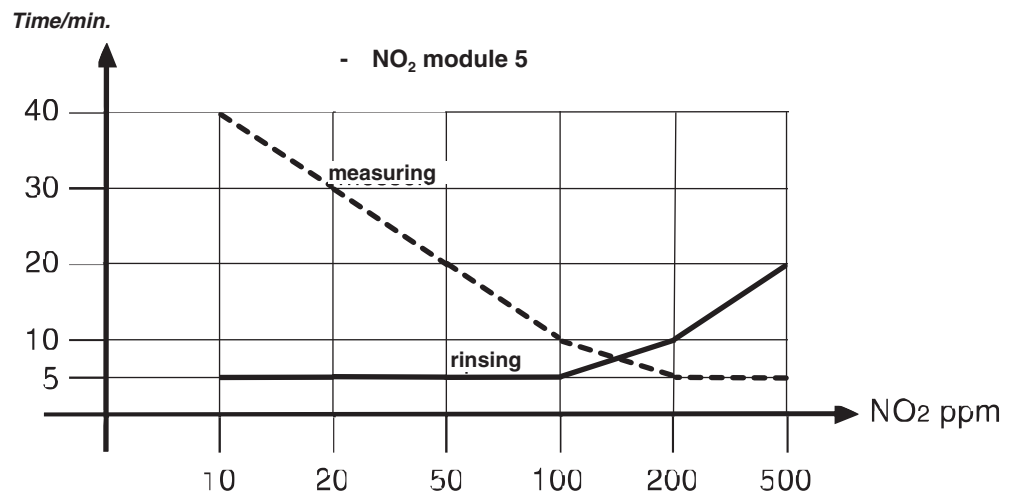

- SO<sub>2</sub> module 6

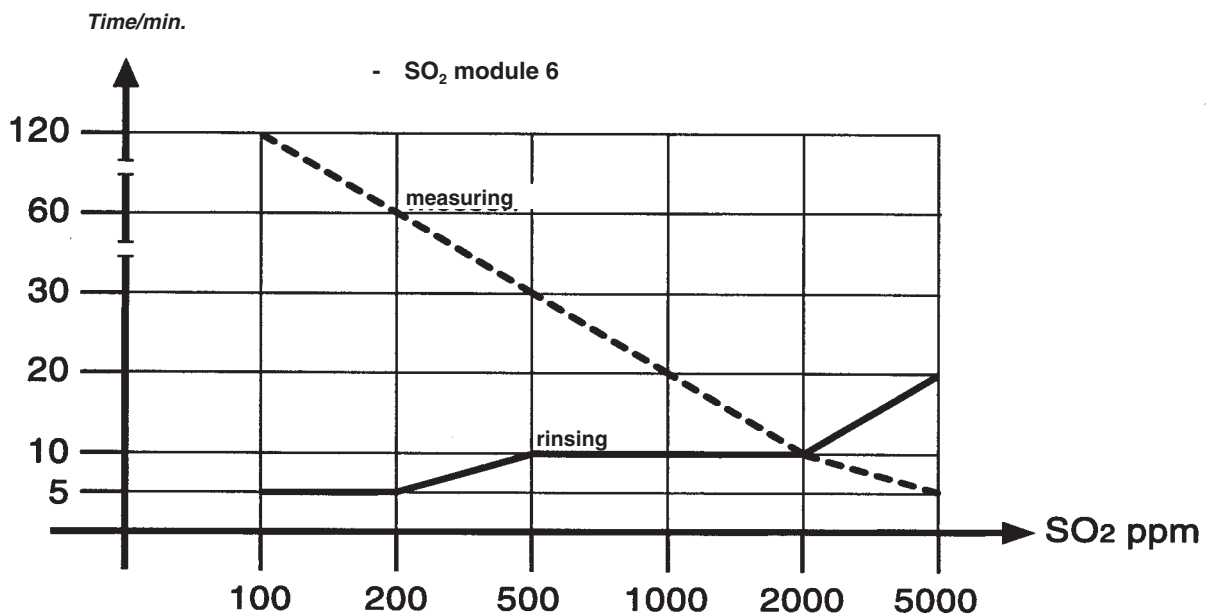



When carrying out NO<sub>2</sub> and SO<sub>2</sub> measurements extra steps must be taken in order to achieve optimal measurements. This is due to the absorption effect of these gases in water.

Condensate which precipitates in the tube and filter absorbs NO<sub>2</sub> and SO<sub>2</sub> which results in a lower concentration display.

Therefore, for short-term measurements of NO<sub>2</sub> and SO<sub>2</sub> the flue gas probes 0600.8521, 0600.8721 or 0600.9523 must be used.

A gas preparation, using **testo 339**, must be carried out during long-term measurements.

#### Comparing accuracy data

Measurements with a heated pipe and testo 339	±20ppm to 400ppm ±5% of m.v. from 400ppm
Flue gas probe with Viton pipe	±20ppm to 200ppm ±10% of m.v. from 200ppm

#### Comparison measurements with **testo 350** and **testo 339**

The following comparison measurements were carried out on an oil burner and a coal heating unit using **testo 350** (heating oil EL) instrument.

	Flue gas probe with heated pipe and gas preparation unit SO <sub>2</sub>	Flue gas probe with Viton pipe and pre-fractionator SO <sub>2</sub>	Standard flue gas probe SO <sub>2</sub>
Fuel Heat. oil EL	44 ppm	34 ppm	9 ppm
Fuel Hard coal	427 ppm	393 ppm	260 ppm

### 4.4 Overpressure/Pressure surges

Overpressure may occur at the gas inlet, in particular during measurements on engines. This leads to extremely high measured values.

If the overpressure is very high (>50 hPa) or there are pressure surges the pipe on the flue gas probe should be screwed off. The pressure is then balanced out at the probe tip.

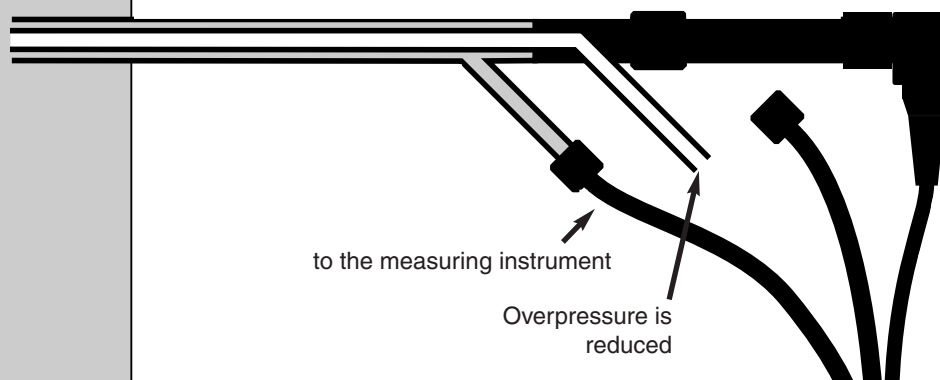



Levels table

Level NN	Air press. (hPa)	Level NN	Air press. (hPa)
0	1013	1250	871
50	1007	1300	866
100	1001	1350	861
150	995	1400	855
200	989	1450	850
250	983	1500	845
300	977	1550	840
350	971	1600	835
400	966	1650	830
450	960	1700	824
500	954	1750	819
550	948	1800	814
600	943	1850	809
650	937	1900	804
700	931	1950	799
750	926	2000	794
<b>800</b>	<b>920</b>	2050	789
850	915	2100	785
900	909	2150	780
950	904	2200	775
1000	898	2250	770
1050	893	2300	765
1100	887	2350	760
1150	882	2400	756
1200	877	2450	751

In order to convert the differential pressure values, measured by the pitot tube, to velocity the air pressure at the measurement location is needed. Before the measurement this air pressure must be entered via the pitot tube factor submenu in the unit hPa (=mbar).  
There are 3 ways to measure the air pressure.

**1. Measuring using the levels table**

The levels table (left) indicates the air pressure absolute values under normal weather conditions for the respective height above sea level.

Example: If the measurement location is 800 m above sea level the value 920 is entered (see Table left)

**2. Measuring the absolute pressure**

Using a suitable absolute pressure measuring instrument the exact value can be measured.

Note: Barometers which are fixed may be corrected to a certain level. The display may correspond to the absolute pressure for 0 m above sea level and not the real current air pressure. In connection with the levels table the following thumb rule can be used to take the current weather into consideration:

Barometer display - 1013 = weather dependent deviation

weather dependent deviation + value from levels table = absolute pressure value

Level NN	Air press. (hPa)	Level NN	Air press. (hPa)
2500	746	3750	636
2550	742	3800	632
2600	737	3850	628
2650	732	3900	624
2700	728	3950	620
2750	723	4000	616
2800	719	4050	612
2850	714	4100	608
2900	709	4150	604
2950	705	4200	600
3000	700	4250	596
3050	696	4300	592
3100	692	4350	588
3150	687	4400	584
3200	683	4450	580
3250	678	4500	577
3300	674	4550	573
3350	670	4600	569
3400	666	4650	565
3450	661	4700	562
3500	657	4750	558
3550	653	4800	554
3600	649	4850	550
3650	644	4900	547
3700	640	4950	543
		5000	540

A sign is added to the weather dependent deviation. If there is low pressure the sign is negative and if the pressure is high the sign is positive. Don't forget this when calculating.

**3. Information from the weather station responsible**

Information on the air pressure for a given level can be attained from the weather station responsible.

**Taking into consideration the pressure difference between the surroundings and the measurement location**

The absolute pressure difference between the location and the measurement location (e.g. chimney) can be taken into consideration as described below.

- a) Absolute pressure measurement directly at the measurement location and input of the measured value or
- b) Measurement of the pressure difference between the measurement location and surroundings and correction of the air pressure value determined beforehand by the difference measured taking the sign into consideration.

Description	Order no.
<b>Upgrading modules</b>	
CO module 1, measuring range 0 to 10 000 ppm, H <sub>2</sub> compensated.....	0554.3503
CO module 2, measuring range 0 to 20 000 ppm .....	0554.3502
CO module 3, measuring range 0 to 40 000 ppm .....	0554.3507
NO module 4, measuring range 0 to 3 000 ppm .....	0554.3504
NO <sub>2</sub> module 5, measuring range 0 to 500 ppm .....	0554.3505
SO <sub>2</sub> module 6, measuring range 0 to 5000 ppm (If NO <sub>2</sub> in the flue gas is > 20 ppm please order NO <sub>2</sub> module) .....	0554.3506
<b>Spare modules</b>	
O <sub>2</sub> spare part set, .....	0390.9003
CO spare module 1, measuring range 0 to 10.000 ppm, H <sub>2</sub> compensated.....	0390.0103
CO spare module 2, measuring range 0 to 20.000 ppm .....	0390.0102
CO spare module 3, measuring range 0 to 40.000 ppm.....	0390.0107
NO spare module 4, measuring range 0 to 3 000 ppm .....	0390.0104
NO <sub>2</sub> spare module 5, measuring range 0 to 500 ppm .....	0390.0105
SO <sub>2</sub> spare module 6, measuring range 0 to 5 000 ppm .....	0390.0106
Filter insert for internal particle filter, (for 10 filter changes).....	0554.0095
Rechargeable battery .....	0515.0035
<b>Flue gas filter insert</b>	
Spare filter material (for flue gas filter insert) .....	0554.3371



**Hauptsitz/Head office**

**Testo AG**

Postfach 11 40, D-79849 Lenzkirch

Testo-Straße 1, D-79853 Lenzkirch

Telefon (0 76 53) 6 81 - 0

Telefax (0 76 53) 6 81 - 1 00

E-Mail: [info@testo.de](mailto:info@testo.de)

<http://www.testo.com>